

SECTION **FAX**
FRONT AXLE

A
B
C

FAX

CONTENTS

E

PRECAUTIONS	2	INSTALLATION	8	F
Precautions	2	Disassembly and Assembly	8	
PREPARATION	3	DISASSEMBLY	8	
Special Service Tools	3	ASSEMBLY	9	G
Commercial Service Tools	3	FRONT DRIVE SHAFT	11	
NOISE, VIBRATION, AND HARSHNESS (NVH)		Removal and Installation	11	
TROUBLESHOOTING	4	REMOVAL	11	H
NVH Troubleshooting Chart	4	INSPECTION AFTER REMOVAL	13	
WHEEL HUB AND KNUCKLE	5	INSTALLATION	13	
On-vehicle Service	5	Disassembly and Assembly	14	
FRONT WHEEL BEARING	5	DISASSEMBLY	15	I
Removal and Installation	6	INSPECTION AFTER DISASSEMBLY	16	
REMOVAL	7	ASSEMBLY	17	
INSPECTION AFTER REMOVAL	8	SERVICE DATA AND SPECIFICATIONS (SDS)	21	J
		Drive Shaft	21	
		Wheel Bearing (Front)	21	

K
L
M

PRECAUTIONS

PRECAUTIONS

PFP:00001

Precautions

EDS003AY

CAUTION:

- **When installing each rubber part, final tightening must be carried out under unladen condition* with tires on ground.**
*: Fuel, radiator coolant and engine oil full. Spare tire, jack, hand tools and mats in designated positions.
- **After installing removed suspension parts, check the wheel alignment.**
- **Do not jack up at lower links.**

Observe the following precautions when disassembling and servicing drive shaft.

- Perform work in a location which is as dust-free as possible.
- Before disassembling and servicing, clean the outside of parts.
- Prevention of the entry of foreign objects must be taken into account during disassembly of the service location.
- Disassembled parts must be carefully reassembled in the correct order. If work is interrupted, a clean cover must be placed over parts.
- Paper shop cloths must be used. Fabric shop cloths must not be used because of the danger of lint adhering to parts.
- Disassembled parts (except for rubber parts) should be cleaned with kerosene which shall be removed by blowing with air or wiping with paper shop cloths.

WHEEL HUB AND KNUCKLE

PF:40202

WHEEL HUB AND KNUCKLE

EDS003B1

On-vehicle Service

Check front axle and front suspension parts for excessive play, cracks, wear or other damage.

- Shake each front wheel to check for excessive play.
- Make sure that cotter pin is inserted.
- Retighten all axle and suspension nuts and bolts to the specification. Refer to [FAX-6, "Removal and Installation"](#) for front axle, and [FSU-5, "Components"](#) for front suspension.

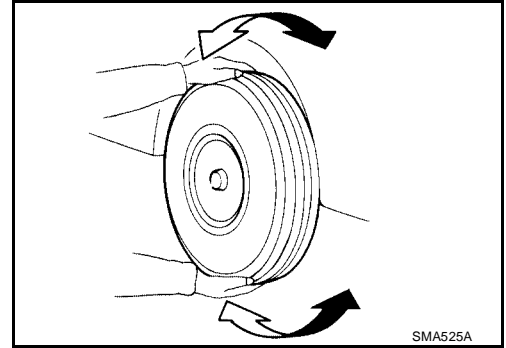

FRONT WHEEL BEARING

- Check that wheel bearings operate smoothly.
- Check axial end play.

Axial end play : 0.07 mm (0.0030 in) or less

If out of specification or wheel bearing does not turn smoothly, replace wheel bearing assembly. Refer to [FAX-6, "Removal and Installation"](#) .

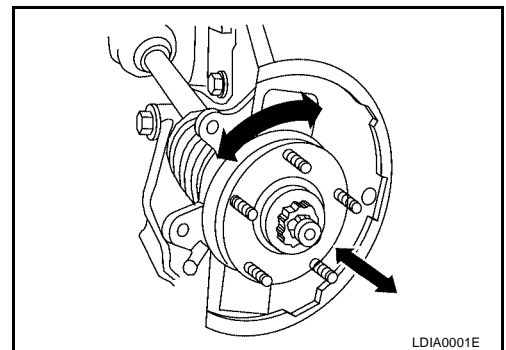

A
B
C
FAX
E
F
G
H
I
J
K
L
M

WHEEL HUB AND KNUCKLE

Removal and Installation

EDS001EQ

SEC. 400

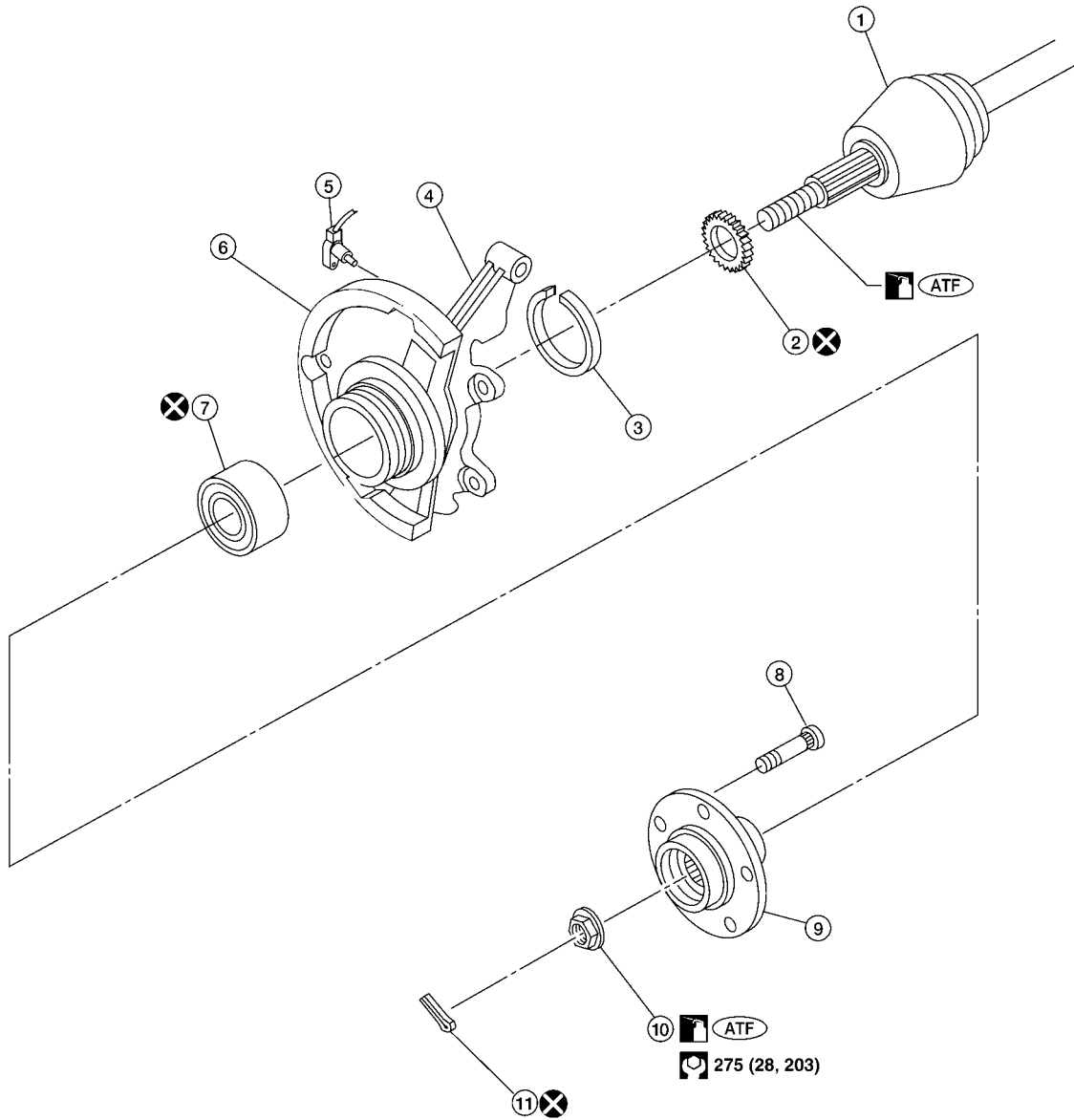

- | | | |
|----------------------------|-----------------|-----------------|
| 1. Drive shaft | 2. Sensor rotor | 3. Snap ring |
| 4. Knuckle | 5. Wheel sensor | 6. Baffle plate |
| 7. Wheel bearing assembly | 8. Hub bolt | 9. Wheel hub |
| 10. Wheel bearing lock nut | 11. Cotter pin | ⇐ Front |

WDIA0317E

WHEEL HUB AND KNUCKLE

REMOVAL

1. Remove wheel and tire. Refer to [WT-6, "Rotation"](#) .
2. Remove the underbody splash shield.
3. Remove the front wheel sensor and reposition aside. Refer to [BRC-41, "Removal and Installation"](#) (TCS/ABS), [BRC-94, "Removal and Installation"](#) (VDC/TCS/ABS).

CAUTION:

Before removing the front axle assembly, remove the wheel sensor from the assembly. Then move it away from the front axle assembly area.

Failure to do so may result in damage to the sensor wires and the wheel sensor becoming inoperative.

4. Remove wheel bearing lock nut, using power tool.
5. Remove brake caliper assembly and rotor using power tool. Refer to [BR-25, "Removal and Installation of Caliper Assembly and Disc Rotor"](#) .
 - Brake hose need not be disconnected from brake caliper. In this case, suspend caliper assembly with wire so as not to stretch brake hose. Be careful not to depress brake pedal, or piston will pop out.
 - Make sure brake hose is not twisted.

6. Separate tie rod from knuckle using Tool.

Tool number : HT72520000 (J-25730-A)

CAUTION:

Install stud nut on stud bolt to prevent damage to stud bolt.

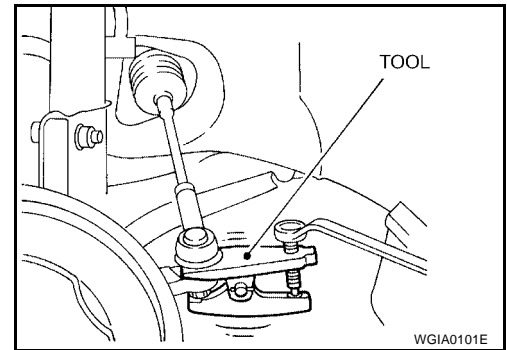

7. Separate drive shaft from knuckle by lightly tapping the end with a suitable tool and wood block. If it is hard to separate, use a suitable puller.

CAUTION:

Cover boots with shop towel so as not to damage them when removing drive shaft.

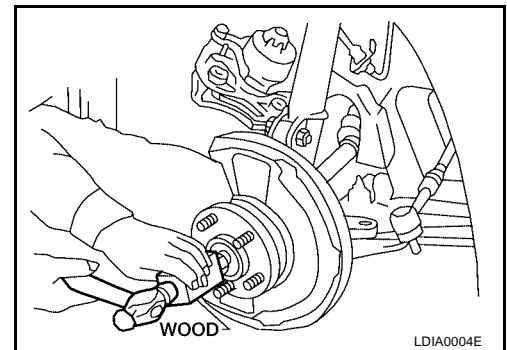

8. Remove lower shock absorber (strut) bolts.

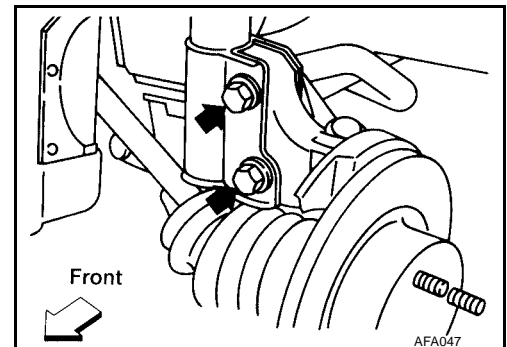

9. Loosen lower ball joint nut.

WHEEL HUB AND KNUCKLE

10. Separate knuckle from lower ball joint stud using Tool.

Tool number : HT72520000 (J-25730-A)

11. Remove knuckle from transverse link.

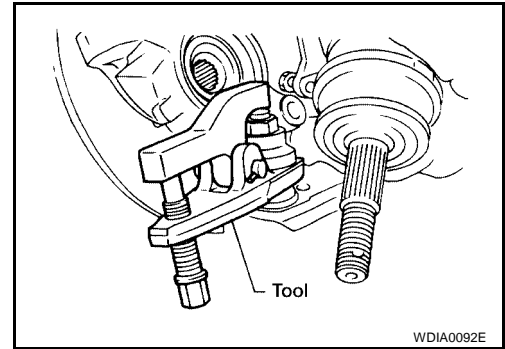

INSPECTION AFTER REMOVAL

Wheel Hub

- Check wheel hub for cracks by a magnetic exploration or dying test, and replace if cracked.

Knuckle

- Check for deformity, cracks (by magnetic exploration or dying test) and damage on steering knuckle, replace if necessary.

Snap Ring

- Check for wear and damage on snap ring, replace if necessary.

INSTALLATION

Installation is in the reverse order of removal.

- Tighten front suspension and power steering components to specification. Refer to [FSU-5, "Components"](#) for front suspension, and [PS-19, "Removal and Installation"](#) for power steering.

Disassembly and Assembly

EDS001ER

DISASSEMBLY

CAUTION:

- When removing wheel hub or wheel bearing from knuckle, replace wheel bearing assembly (outer race, inner races and grease seals) with a new one.
 - When replacing wheel bearing, replace complete wheel bearing assembly (inner races and outer race).
1. Press out wheel hub from knuckle, using a suitable tool.

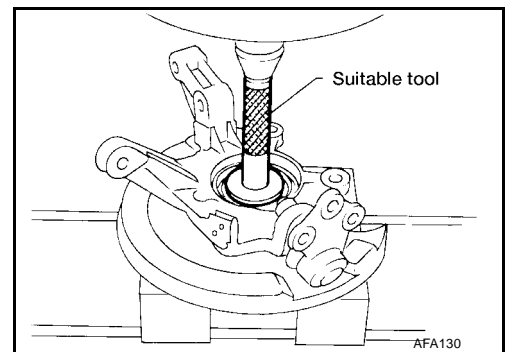

2. Remove snap rings.

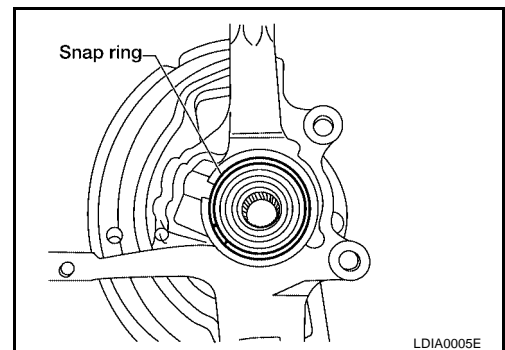

WHEEL HUB AND KNUCKLE

3. Press out wheel bearing from knuckle.

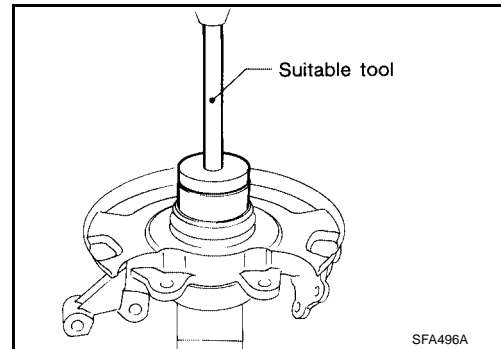

ASSEMBLY

1. Install inner snap ring into groove of knuckle.
2. Press new wheel bearing assembly into knuckle until it contacts snap ring using suitable tool.

Maximum load "P" : 50 kN (5.1 ton, 5.6 US ton, 5.02 Imp ton)

CAUTION:

- Do not press inner race of wheel bearing assembly.
- Do not apply oil or grease to mating surfaces of wheel bearing outer race and knuckle.

3. Install outer snap ring into groove of knuckle using suitable tool.

4. Press wheel hub into knuckle using suitable tool.

Maximum load "P" : 50 kN (5.1 ton, 5.6 US ton, 5.02 Imp ton)

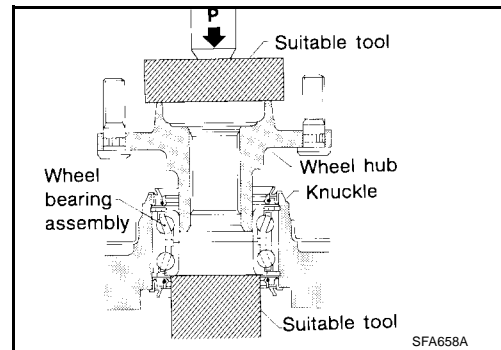
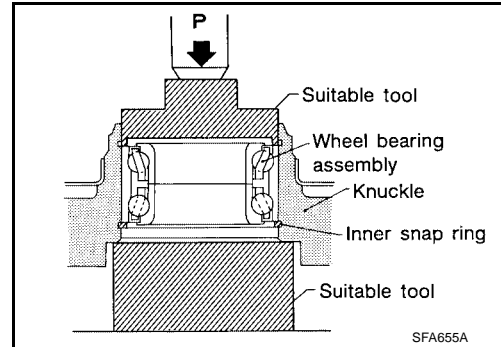

5. Check bearing operation.

- a. Add load "P" with press.

Load "P" : 35 - 50 kN (3.6 - 5.1 ton, 3.9 - 5.6 US ton, 3.51 - 5.02 Imp ton)

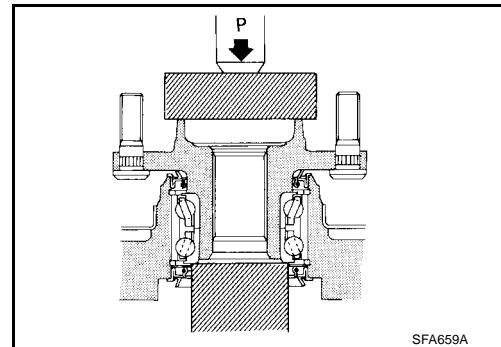

A
B
C
FAX

E
F
G
H
I
J
K
L
M

WHEEL HUB AND KNUCKLE

- b. Spin knuckle several turns in both directions.
- c. Make sure that wheel bearings operate smoothly.

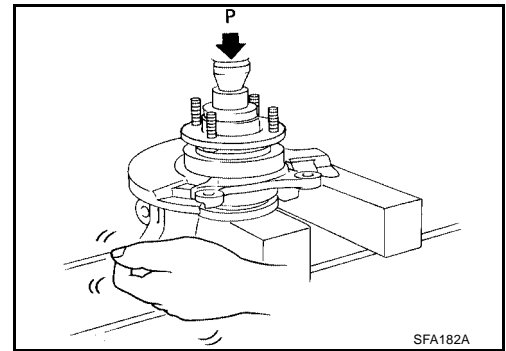

FRONT DRIVE SHAFT

PF39100

FRONT DRIVE SHAFT

Removal and Installation

EDS001ES

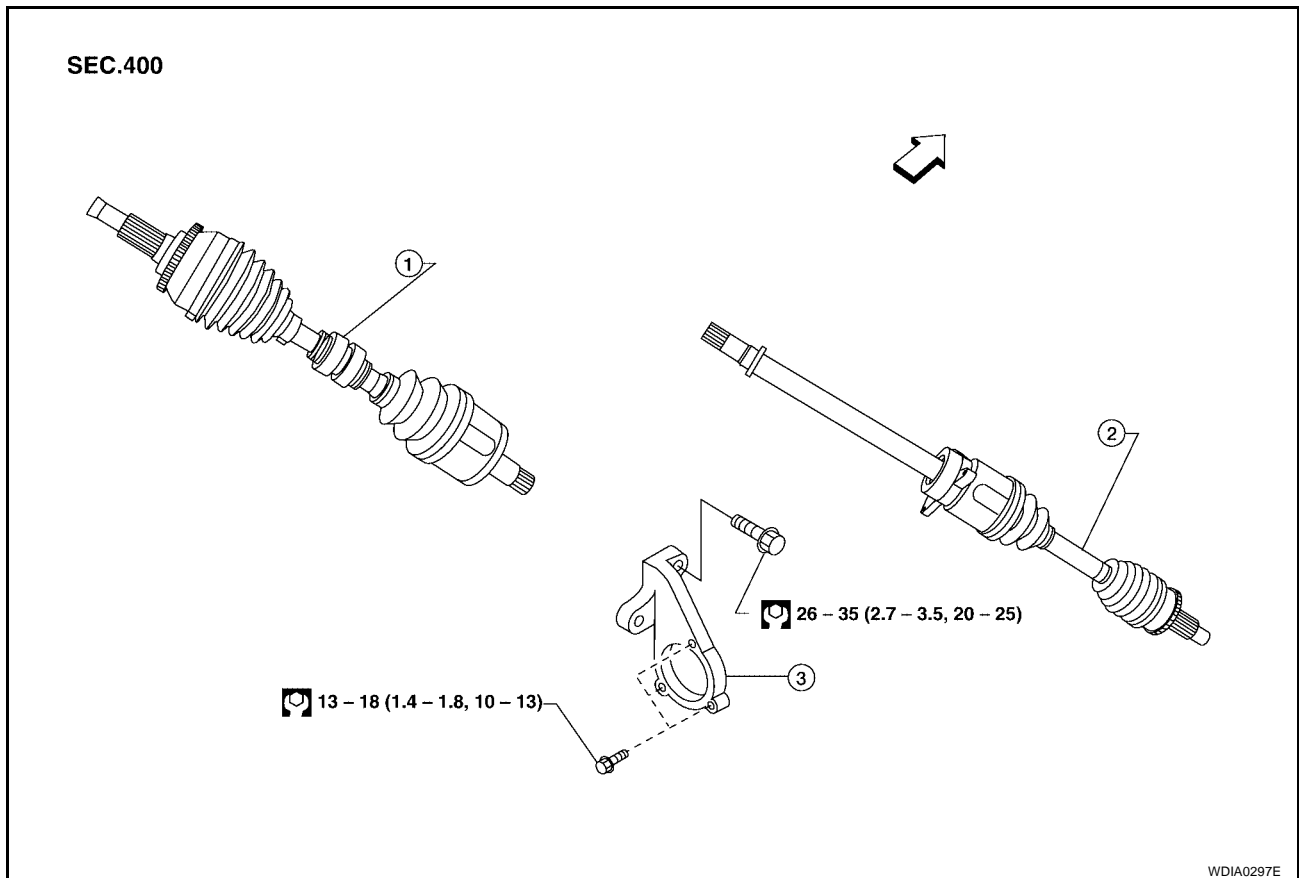

1. LH drive shaft
← Front

2. RH drive shaft

3. Center support bracket

CAUTION:

- Circular clips should be properly meshed with the differential side gear (transaxle side). Check that the circular clips are properly seated after installation and that the drive shaft will not come out. Always use a new circular clip for installation.
- Use a suitable cloth or protector over the boots to prevent damage to the boots during removal and installation.

REMOVAL

1. Remove the wheel and tire. Refer to [WT-6, "Rotation"](#).
2. Remove brake caliper assembly and disc rotor. Refer to [BR-25, "Removal and Installation of Caliper Assembly and Disc Rotor"](#).

CAUTION:

- Do not twist or stretch the brake hose when removing components.
- Discard the cotter pin and use a new cotter pin for installation.

NOTE:

The brake caliper does not need to be disconnected.

3. Remove the cotter pin, and the wheel bearing lock nut using power tool.
4. Remove the underbody splash shield.
5. Remove the lower ball joint cotter pin and nut using power tool.

CAUTION:

Discard the cotter pin and use a new cotter pin for installation.

FRONT DRIVE SHAFT

6. Disconnect the lower ball joint from the steering knuckle using Tool as shown.

CAUTION:

Discard the cotter pin and use a new cotter pin for installation.

Tool number : HT7252000 (J-25730-A)

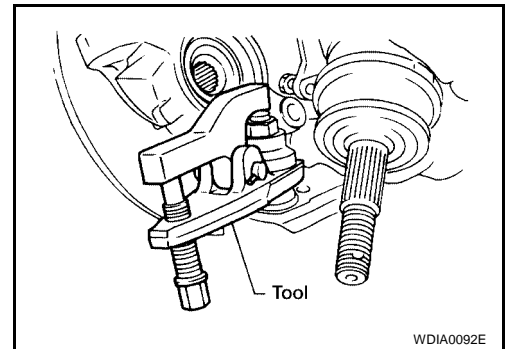

7. Disconnect the connecting rod from the front strut. Refer to [FSU-11, "Removal and Installation"](#).

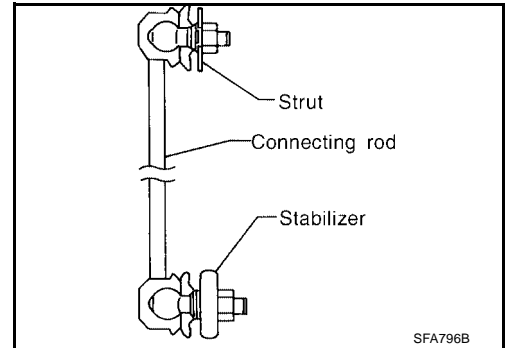

8. Separate drive shafts from the knuckles by lightly tapping the end with a suitable tool and a wood block as shown. If it is hard to separate, use a suitable puller.

CAUTION:

Cover boots with shop towel so as not to damage them when removing drive shaft.

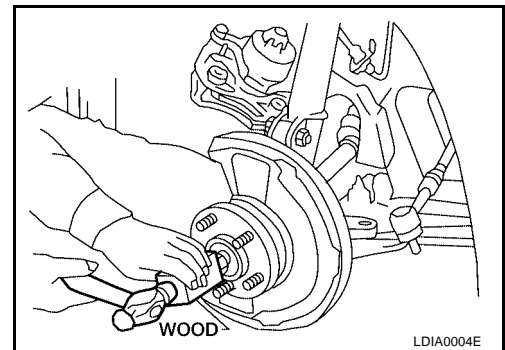

9. Remove the center support bearing bolts using power tool, and pry the righthand drive shaft out of the transaxle using a suitable tool as shown.

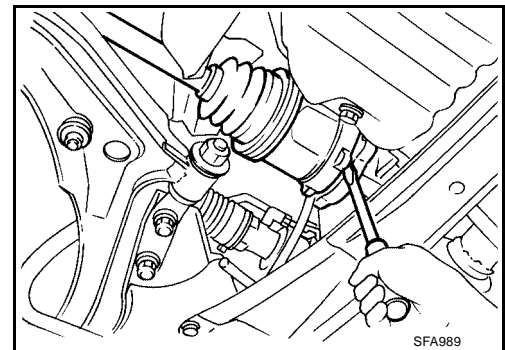

10. Remove the lefthand drive shaft from the transaxle.
- Remove drive shaft from transaxle using Tool and drive shaft puller or suitable tool.
 - Set Tool and a drive shaft puller or suitable tool between drive shaft (slide joint side) and transaxle as shown, then remove drive shaft.

Tool number : KV40107500 (—)

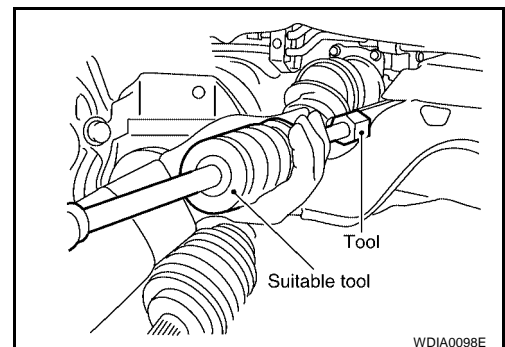

FRONT DRIVE SHAFT

11. Remove the circular clip from the transaxle side of the drive shaft and discard.

CAUTION:

Always use a new circular clip for installation.

INSPECTION AFTER REMOVAL

- Check for halting movement or a noticeable rattle by moving a joint part vertically, horizontally and to axial direction.
- Check for crack damage and grease leak of boot.

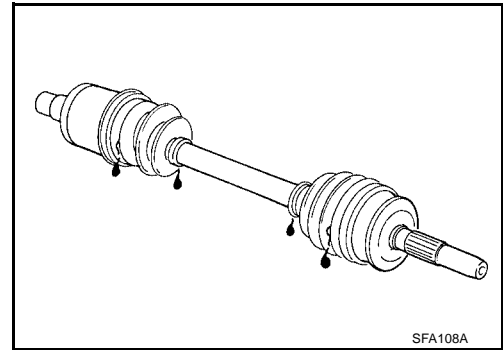

INSTALLATION

Transaxle Side

1. On models equipped with M/T, drive a new oil seal into transaxle case. Refer to [MT-11, "SIDE OIL SEAL"](#).
2. Set Tool along the inner circumference of oil seal.

Tool number : KV38106800 (J-34297)

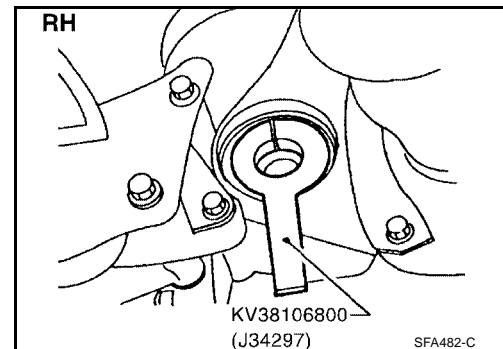

3. Install a new circular clip on the drive shaft.

CAUTION:

Always use a new circular clip for installation.

4. Insert drive shaft into transaxle. Be sure to properly align the serrations and then withdraw Tool.

Tool number : KV38106700 (J-34296)

5. Push drive shaft, then press-fit the circular clip on the drive shaft into circular clip groove of side gear.
6. After its insertion, try to pull the flange out of the slide joint by hand. If it pulls out, the circular clip is not properly meshed with the side gear.
7. Installation of the remaining components in the reverse order of removal.

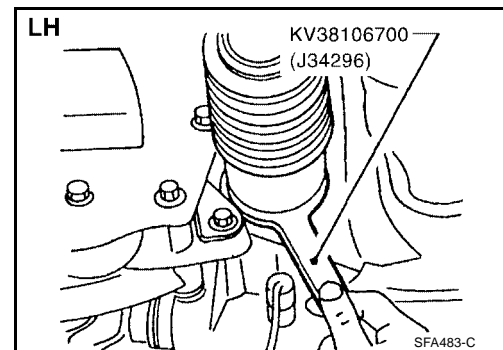

Wheel Side

1. Install the drive shaft into the knuckle.
2. Install the wheel bearing lock nut and tighten to specification. Refer to [FAX-6, "Removal and Installation"](#).
3. Install a new cotter pin to secure the wheel bearing lock nut.

CAUTION:

Always use a new cotter pin for installation.

4. Installation of the remaining components in the reverse order of removal.

FRONT DRIVE SHAFT

EDS001ET

Disassembly and Assembly

SEC. 400

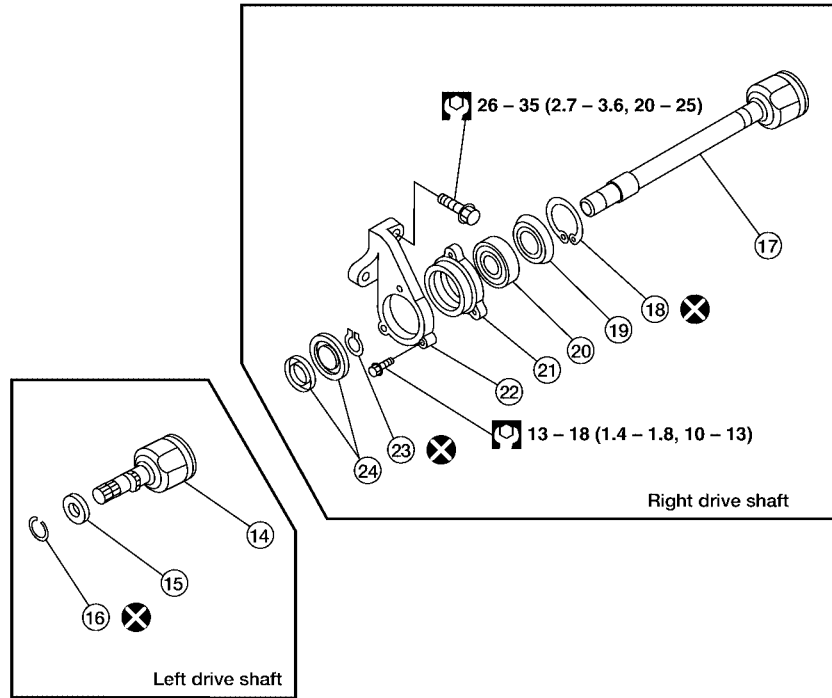
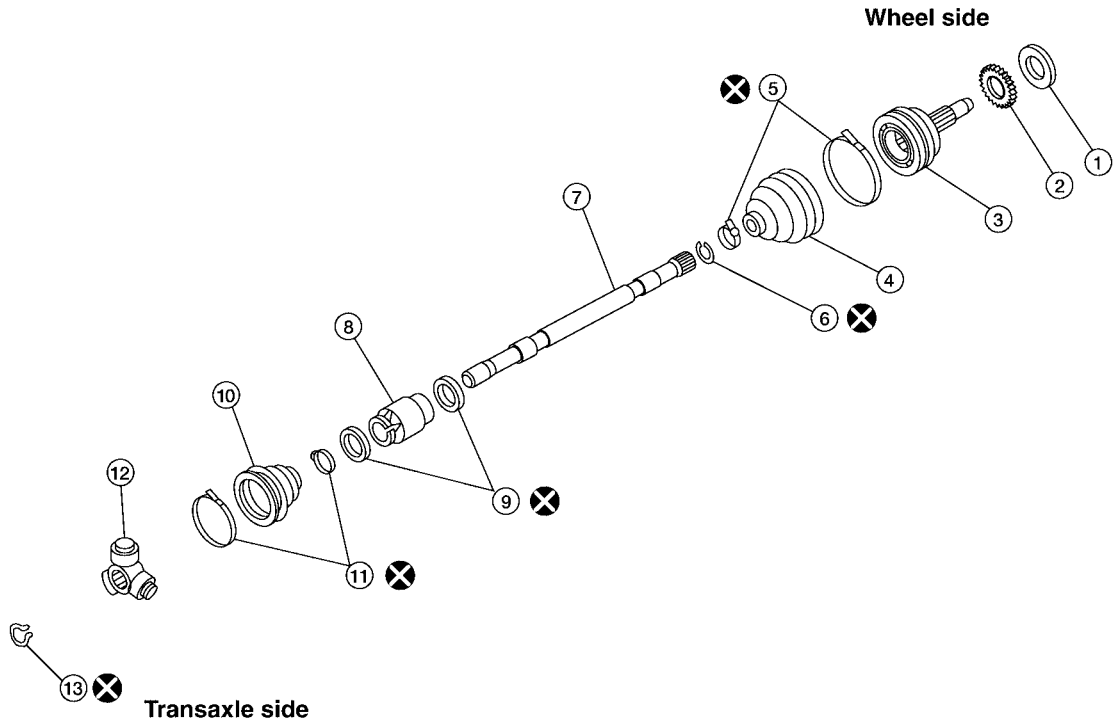

: N-m (kg-m, ft-lb)

: Always replace after every disassembly

- | | | |
|-------------------|--|------------------------|
| 1. Dust shield | 2. Sensor rotor | 3. Joint assembly |
| 4. Boot | 5. Boot band | 6. Circular clip |
| 7. Drive shaft | 8. Dynamic damper | 9. Dynamic damper band |
| 10. Boot | 11. Boot band | 12. Spider assembly |
| 13. Snap ring | 14. Slide joint housing | 15. Dust shield |
| 16. Circular clip | 17. Slide joint housing with extension shaft | 18. Snap ring |

WDIA0025E

FRONT DRIVE SHAFT

19. Dust shield

20. Center support bearing

21. Center support bearing retainer

22. Center support bracket

23. Snap ring

24. Dust shield

DISASSEMBLY

Transaxle Side

1. Remove boot bands.
2. Put matching marks on slide joint housing and drive shaft, before separating the slide joint assembly.
3. Put matching marks on the spider assembly and drive shaft.

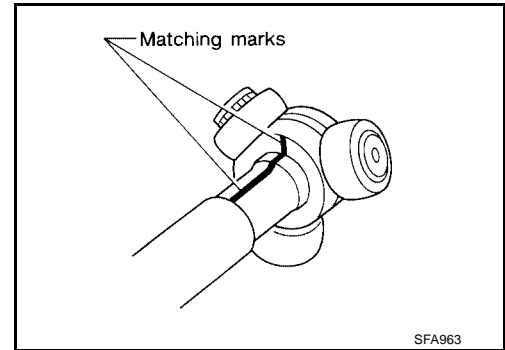

4. Remove the snap ring, then remove the spider assembly.
5. Remove the boot using suitable tool.

CAUTION:

Cover the drive shaft serrations with tape so as not to damage the boot.

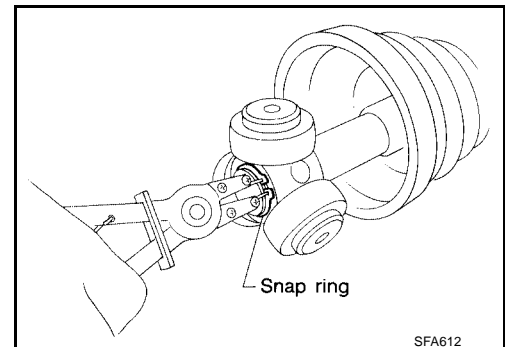

Wheel Side

CAUTION:

The joint on the wheel side cannot be disassembled.

1. Before separating joint assembly from the drive shaft, put matching marks on drive shaft and joint assembly.
2. Separate joint assembly from the drive shaft using a suitable tool.

CAUTION:

Do not damage the threads on the drive shaft when separating the joint.

3. Remove boot bands.
4. Remove the boot.

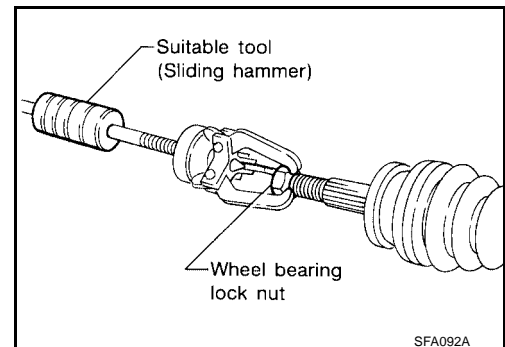

FRONT DRIVE SHAFT

Support Bearing

1. Remove dust shield using a suitable tool.

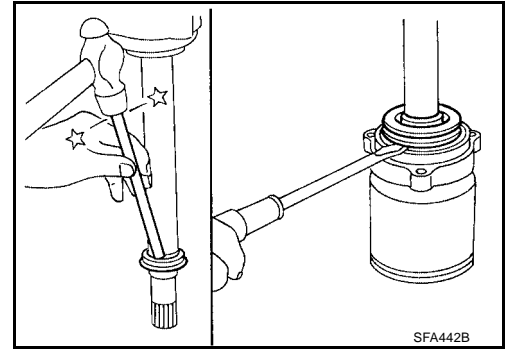

2. Remove snap ring using a suitable tool.

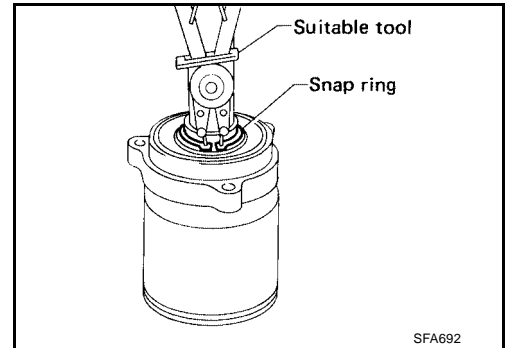

3. Press support bearing assembly off drive shaft using a suitable tool.

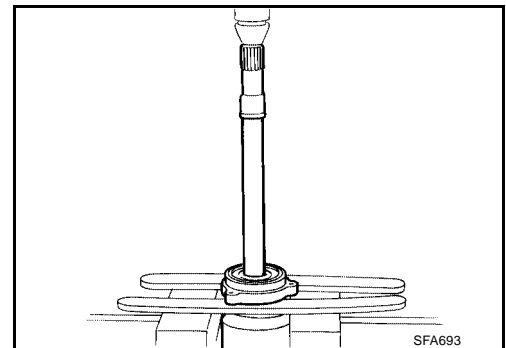

4. Separate support bearing from retainer using a suitable tool.

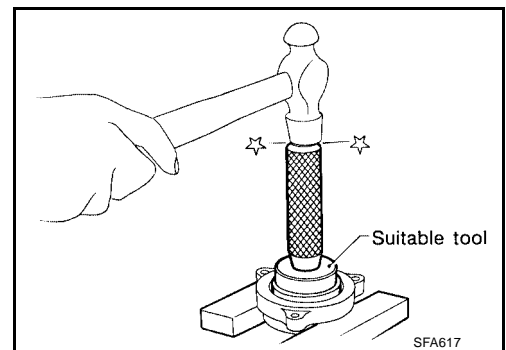

INSPECTION AFTER DISASSEMBLY

Thoroughly clean all parts in cleaning solvent, and dry with compressed air. Check parts for evidence of deformation or other damage. Replace as necessary.

Shaft

Replace drive shaft if it is twisted or cracked.

Joint Assembly (Transaxle Side)

- Check serration for deformation. Replace if necessary.
- Check slide joint housing and spider assembly for any damage. Replace if necessary.

FRONT DRIVE SHAFT

CAUTION:

The slide joint housing and spider assembly must be replaced as a set, even if only one component is damaged then both must be replaced.

Joint Assembly (Wheel Side)

Replace joint assembly if it is deformed or damaged.

Housing (Slide Joint)

- Check for damage or abnormal wear on ball rolling surface.
- Check for wear on shaft bolts.
- Check for deformity on boot install part.

Support Bearing

Make sure wheel bearing rolls freely and is free from noise, cracks, pitting or wear.

ASSEMBLY

CAUTION:

- After drive shaft has been assembled, ensure that it moves smoothly over its entire range without binding.
- Use Genuine NISSAN Grease or equivalent after every overhaul.

Transaxle Side

1. Install boot and new small boot band on drive shaft.

CAUTION:

Cover drive shaft serration with tape so as not to damage boot during installation.

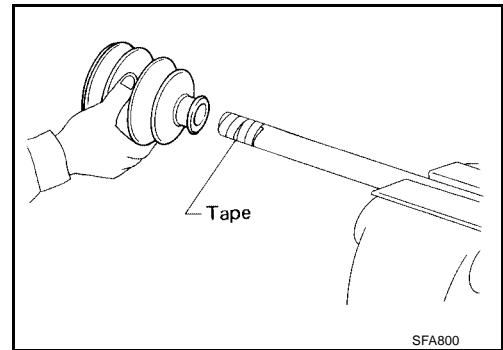

2. Install the spider assembly securely, making sure the marks which were made during disassembly are properly aligned.
3. Install a new snap ring using a suitable tool.
4. Pack the drive shaft joint with the specified amount of grease.

Drive shaft joint grease capacity

M/T : 245 - 255 g (8.64 - 8.99 oz)

A/T : 134 - 144 g (4.73 - 5.08 oz)

5. Install the slide joint housing.

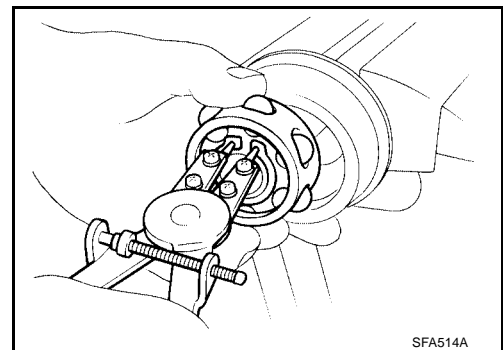

6. Make sure that the boot is properly installed on the drive shaft groove.

- Set the boot so that it does not swell and deform when its length is "L2".

Length "L2" : 164.7 - 172.7 mm (6.48 - 6.80 in)

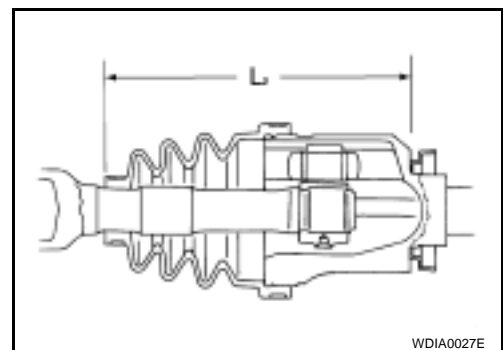

FRONT DRIVE SHAFT

- Lock the new larger and smaller boot bands securely using a suitable tool.

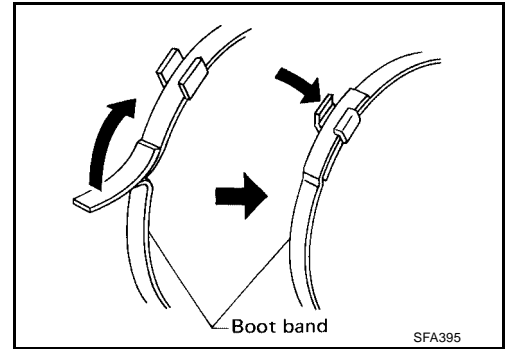

Wheel Side

- Press on the wheel sensor rotor to the joint sub-assembly using a suitable tool.

CAUTION:

Always use new wheel sensor rotor.

- Install boot and new small boot band on drive shaft.

CAUTION:

Cover drive shaft serration with tape so as not to damage boot during installation.

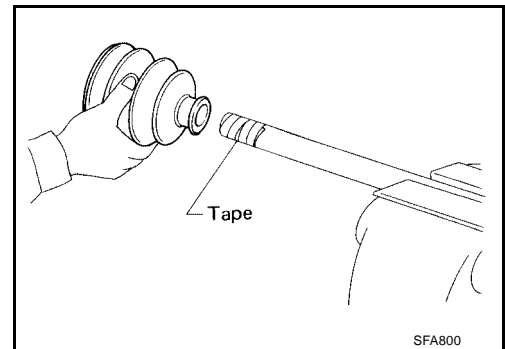

- Set joint assembly onto drive shaft by lightly tapping it as shown.

NOTE:

Install joint assembly securely, ensuring marks which were made during disassembly are properly aligned.

- Pack drive shaft joint with the specified amount of grease.

Joint grease capacity : 100 - 110 g (3.53 - 3.88 oz)

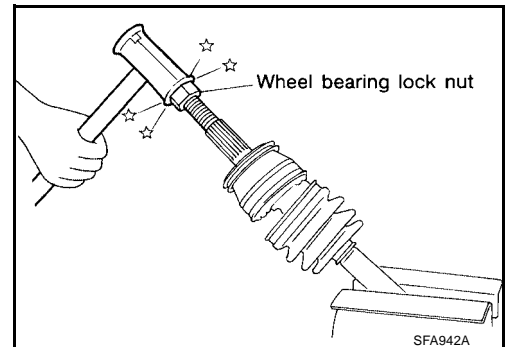

- Make sure that boot is properly installed on the drive shaft groove.

- Set the boot so that it does not swell and deform when the length is "L1".

Length "L1" : 163 mm (6.42 in)

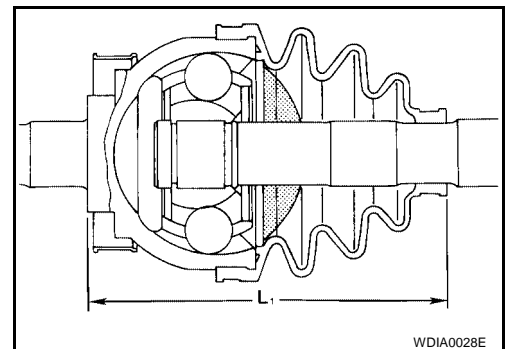

FRONT DRIVE SHAFT

6. Lock new larger and smaller boot bands securely using Tool.

Tool number : KV40107300 (—)

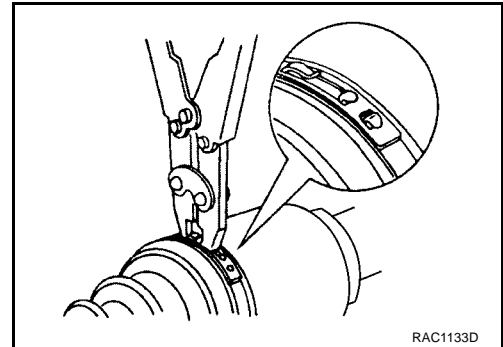

7. Measure criped area of boot bands after installation.

CAUTION:

**Secure boot band so that dimemnsion "M" meets specifica-
tion as shown.**

Dimension "M" : 1.0 – 4.0 mm (0.039 – 0.157 in)

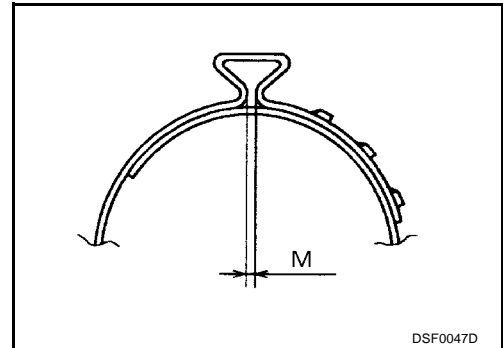

Dynamic Damper

1. Use new damper bands when installing.
2. Install dynamic damper from stationary-joint side while holding it securely.

Length "A" : 205 - 215 mm (8.07 - 8.46 in)

Length "B" : 50 mm (1.97 in)

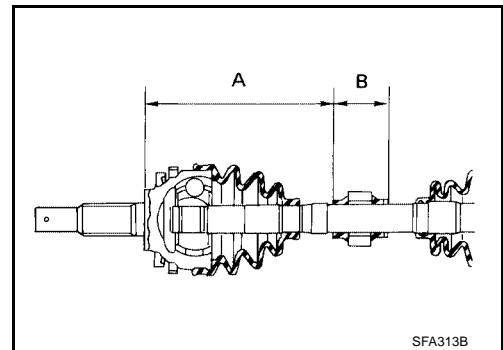

Support Bearing

1. Press bearing into retainer using a suitable tool.

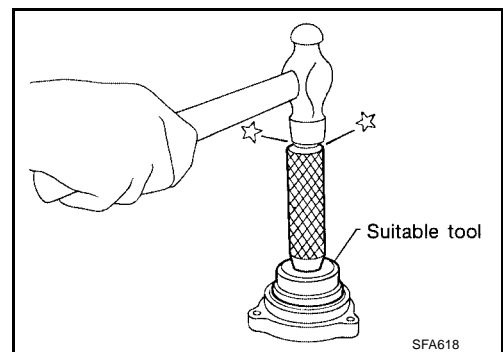

A
B
C

FAX

E
F
G

H
I
J

K
L
M

FRONT DRIVE SHAFT

2. Press drive shaft into bearing using a suitable tool.

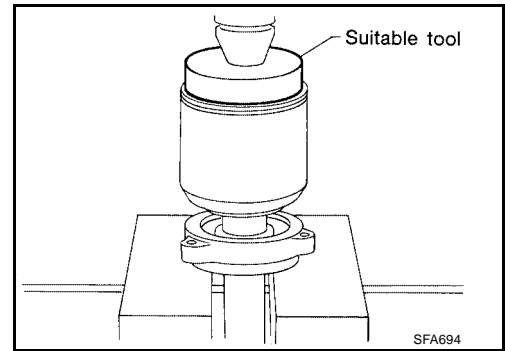

SERVICE DATA AND SPECIFICATIONS (SDS)

SERVICE DATA AND SPECIFICATIONS (SDS)

PF0:00030

Drive Shaft

EDS001EU

Transaxle side

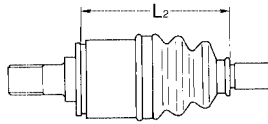

WDIA0029E

Wheel side

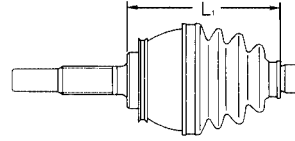

WDIA0030E

A
B
C

FAX

E
F

G

H

I

J

K

L

M

Grease capacity	Specification		NISSAN Genuine Grease or equivalent
	Transaxle side	A/T	134 - 144 g (4.73 - 5.08 oz)
		M/T	245 - 255 g (8.64 - 8.99 oz)
	Wheel side		100 - 110 g (3.53 - 3.88 oz)
Boot length	Transaxle side "L2 "		164.7 - 172.7 mm (6.48 - 6.80 in)
	Wheel side "L1 "		163 mm (6.42 in)

Wheel Bearing (Front)

EDS001EV

Wheel bearing axial end play limit	0.07 mm (0.003 in) or less
Wheel bearing lock nut tightening torque	236 - 313 N·m (24 - 31 kg·m, 174 - 230 ft·lb)

SERVICE DATA AND SPECIFICATIONS (SDS)
