

NISSAN MAXIMA



1993 OWNER'S MANUAL

Foreword

Welcome to the growing family of new NISSAN owners. This vehicle is delivered to you with confidence. It was produced using the latest techniques and strict quality control.

This manual was prepared to help you understand the operation and maintenance of your vehicle so that you may enjoy many miles of driving pleasure. Please read through this manual before operating your vehicle.

A separate "Warranty Information booklet" explains details about the warranties covering your vehicle.

Your NISSAN dealer knows your vehicle best. When you require any service or have any questions, he will be glad to assist you with the extensive resources available to him.

IMPORTANT SAFETY INFORMATION REMINDERS FOR SAFETY!

Follow these three important driving rules to help ensure a safe and complete trip for you and your passengers!

- **NEVER** drive under the influence of alcohol or drugs.
- **ALWAYS** observe posted speed limits and never drive too fast for conditions.
- **ALWAYS** use your seat belts and appropriate child restraint systems.

NOTES ON THE INFORMATION CONTAINED IN THIS OWNER'S MANUAL

This owner's manual contains descriptions and operating instructions for all systems, features and optional equipment that might appear in any model of this vehicle built for any destination in North America, including the continental United States, Canada and Hawaii. Therefore, you may very well find information in this manual that does not apply to your vehicle.

All information, specifications and illustrations in this manual are those in effect at the time of printing. NISSAN reserves the right to change specifications or design without notice and without obligation.

Welcome To The World Of NISSAN

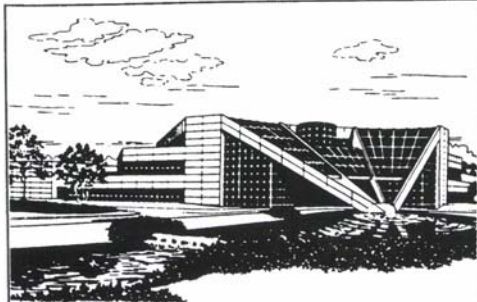

NISSAN RESEARCH & DEVELOPMENT, INC.
in Farmington Hills, Michigan



NISSAN MOTOR MANUFACTURING CORPORATION
U.S.A. in Smyrna, Tennessee

AFW0001

Your new Nissan is the result of our dedication to produce the finest in safe, reliable and economical transportation. Your vehicle is the product of a successful worldwide company that manufactures cars and trucks in over 20 countries and distributes them in 150 nations.

Nissan vehicles are designed and manufactured by Nissan Motor Co., Ltd. which was founded in Tokyo, Japan in 1933, and Nissan affiliates world wide, collectively growing to become the fourth largest automaker in the world. In addition to cars and trucks, Nissan also makes textile machinery, forklift trucks, marine engines, boats and other products.

Nissan has made a substantial and growing investment in North America, starting with the opening of Nissan Motor Corporation in U.S.A. in 1960 and continuing with the production of some cars and trucks at one of the world's most

modern manufacturing facilities in Smyrna, Tennessee, vehicle styling at Nissan Design International in San Diego, California, and engineering at Nissan Research and Development in Farmington Hills, Michigan.

Nissan Motor Corporation in U.S.A. and its dealers employ about 50,000 Americans.

Nissan is also a substantial contributor to the Canadian economy. Nissan Canada Inc. and its 200 dealers and suppliers employ approximately 4,000 people. These include company employees and the staffs of Nissan dealers all across Canada. In addition, many Canadians work for companies that supply Nissan and Nissan dealers with materials and services ranging from operation of port facilities and transportation services, to the supply of lubricants, parts and accessories.

Nissan pioneered the use of electronics and computers in automobiles, and has led the industry in improving both performance and fuel efficiency through new engine designs and the use of synthetic materials to reduce vehicle weight. The company has also developed ways to build quality into its vehicles at each stage of the production process, both through extensive use of automation and — most importantly — through an awareness that **people** are the central element in quality control.

From the time the parts arrived from our suppliers until you took delivery of your new Nissan, dozens of checks were made to ensure that only the best job was being done in producing and delivering your vehicle. Nissan also takes great care to ensure that when you take your Nissan to your dealer for maintenance, the service technician will perform his work according to the quality standards that have been established by the factory.

Safety has also been built into your Nissan. As you know, seat belts are an integral part of the safety systems that will help protect you and your passengers in the event of a sudden stop or an accident. We urge you to use the belts every time you drive the vehicle.

The Nissan story of growth and achievement reflects our major goal: to provide you, our customer, with a vehicle that is built with quality and craftsmanship — a product that we can be proud to build and you can be proud to own.

NISSAN CUSTOMER CARE PROGRAM

NISSAN CARES ...

Both NISSAN and your NISSAN dealer are dedicated to serving all your automotive needs. Your satisfaction with your vehicle and your NISSAN dealer are our primary concerns. Your NISSAN dealer is always available to assist you with all your automobile sales and service needs.

However, if there is something that your NISSAN dealer can not assist you with or you would like to provide NISSAN directly with comments or questions, please contact our (NISSAN's) Consumer Affairs Department using our toll-free number:

For U.S. mainland customers

1-800-NISSAN-1 (1-800-647-7261)

For Hawaii customers

531-0231 (Oahu Number)

For Canada customers

1-800-387-0122

The Consumer Affairs Department will ask for the following information:

- Your name, address, and telephone number
- Vehicle identification number (on dashboard)
- Date of purchase
- Current odometer reading
- Your NISSAN dealer's name
- Your comments or questions

OR

You can write to NISSAN with the information on the left at:

For U.S. mainland customers

Nissan Motor Corporation in U.S.A.

Consumer Affairs Department

P.O. Box 191

Gardena, California 90247

For Hawaii customers

Nissan Motor Corporation in Hawaii

2880 Kilihau St.

Honolulu, Hawaii 96819

For Canada customers

Nissan Canada Inc.

P.O. Box 1709, Station "B"

Mississauga, Ontario L4Y 4H6

We appreciate your interest in NISSAN and thank you for buying a quality NISSAN vehicle.

Contents

Instruments and controls	1
Pre-driving checks and adjustments	2
Heater, air conditioner and audio system	3
Starting and driving	4
In case of emergency	5
Appearance and interior care	6
Do-it-yourself operations	7
Maintenance schedule	8
Technical and consumer information	9
Index	10

1 Instruments and controls

[Meters and gauges]

Digital (electronic) meter	1-3
Analog (needle-type) meter	1-6
Warning/indicator light and chime	1-9
Theft warning	1-12

[Switches]

Windshield wiper and washer switch	1-13
Rear window defogger switch	1-14
Outside mirror defogger switch	1-14
Headlight and turn signal switch	1-15
Cornering light	1-16
Instrument brightness control	1-16
Front fog light switch	1-16
Hazard warning flasher switch	1-17
Cigarette lighter and ash trays	1-17
Pocket and cup holder	1-18
Power window	1-19
Sun roof	1-20
Clock	1-21

[Interior lights]

Interior light	1-22
Front personal light	1-22

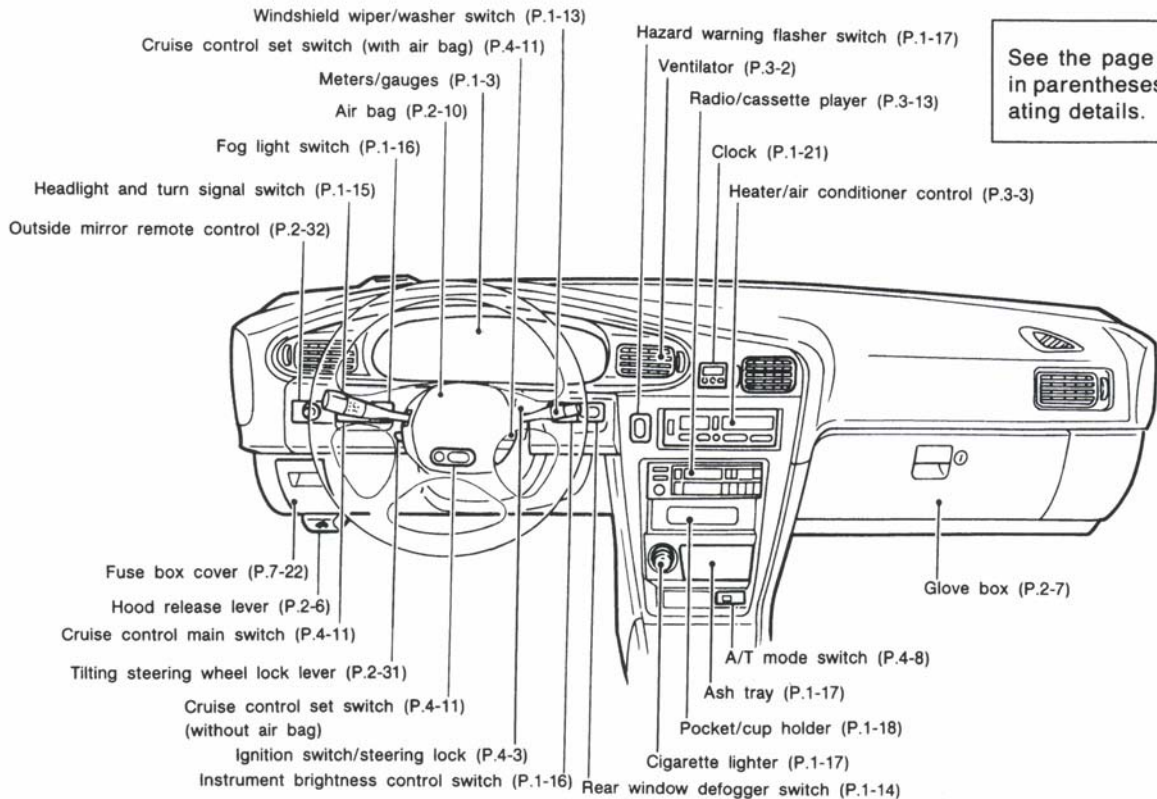

See the page indicated
in parentheses for oper-
ating details.

DIGITAL (ELECTRONIC) METER

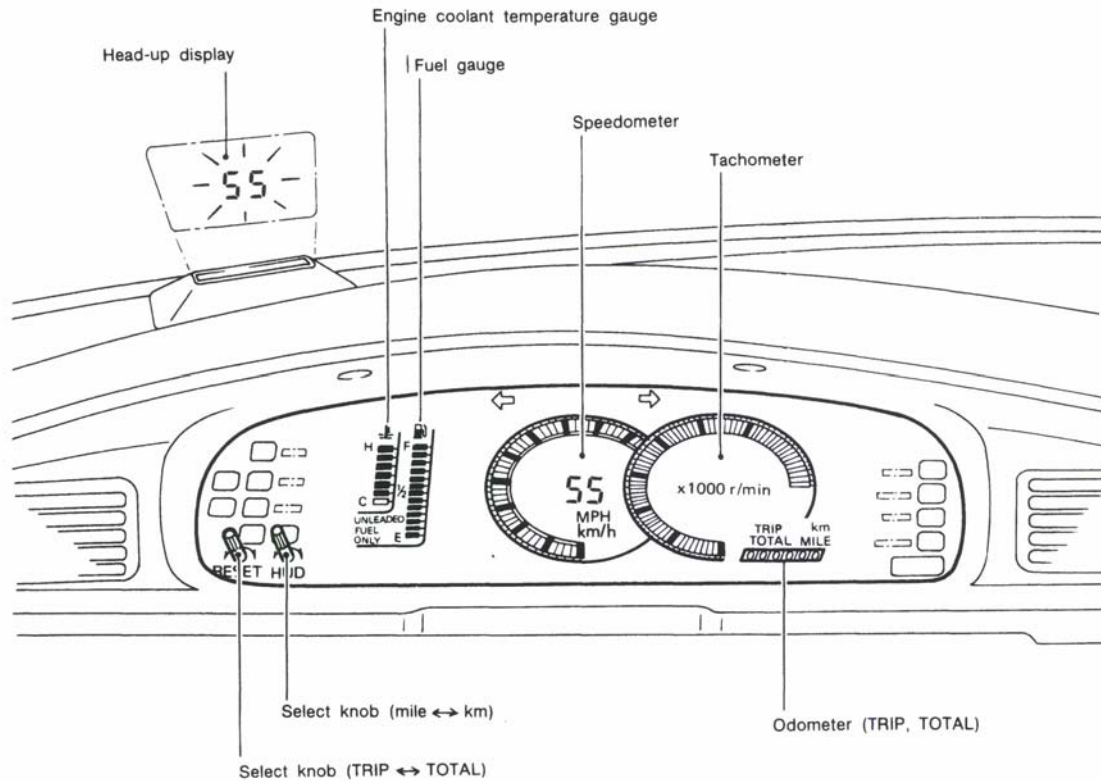

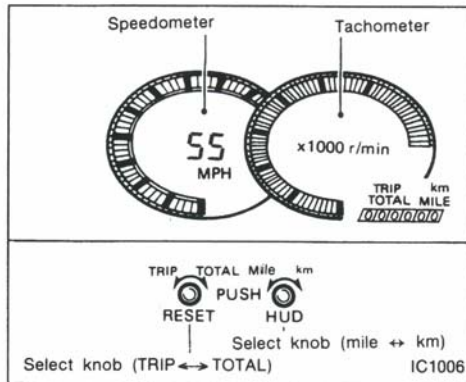

To operate the digital meter, turn the ignition key to the "ON (3)" position.

SPEEDOMETER

The speedometer indicates vehicle speed.

Turn the select knob (mile ↔ km) to change the display to: "mile" ↔ "km"

TACHOMETER

The tachometer indicates engine speed in revolutions per minute (r/min).

CAUTION:

When engine speed approaches the red zone, shift to a higher gear. Engine speed in the red zone may cause serious engine damage.

Head-up display

This is a system which allows the driver to view the vehicle speed reflected on the windshield.

Pushing the select knob (mile ↔ km) will display the vehicle speed on the windshield.

Push it again, the display will go out.

Turning the select knob changes the display km/h → MPH or MPH → km/h.

The brightness of the head-up display may be adjusted by the dash panel brightness control located below the tachometer.

NOTE:

- The head-up display may show a double image if the intensity is adjusted too high. If you see a double image, decrease the display brightness.
- When direct sunlight shines onto the

upper dash panel, the head-up display may show "188".

- When cleaning the windshield, use glass cleaner with a piece of clean cloth to remove smoke and dust film from the glass surfaces. Do not use any sharp-edged tools or abrasive cleaners or chlorine-based disinfectant cleaners.

ODOMETER

Turn the select knob (TRIP ↔ TOTAL) to change the display to:

"TRIP" ↔ "TOTAL"

Total odometer

The odometer records the total distance the vehicle has been driven.

Trip odometer

The trip odometer records the distance of individual trips. Before each trip, set the trip odometer to zero by pushing the select knob (TRIP ↔ TOTAL).

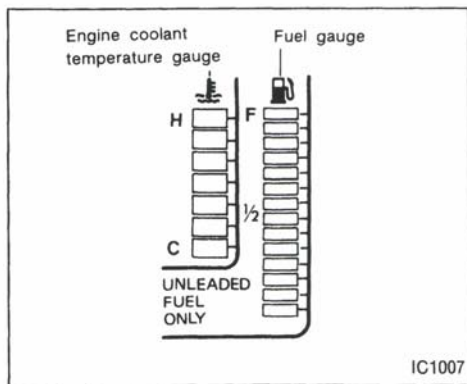

ENGINE COOLANT TEMPERATURE GAUGE

The gauge indicates the coolant temperature.

The coolant temperature will vary with the outside air temperature and driving conditions.

CAUTION:

If the gauge indicates over the normal range, stop the vehicle as soon as safely possible. If the engine is overheated, continued operation of the vehicle may seriously damage the engine. See "In case of emergency" section for immediate action required.

FUEL GAUGE

The gauge indicates the APPROXIMATE fuel level in the tank.

The gauge may move slightly during braking, turning, acceleration, or going up or down hill.

Refill the fuel tank before the gauge registers Empty.

ANALOG (NEEDLE-TYPE) METER

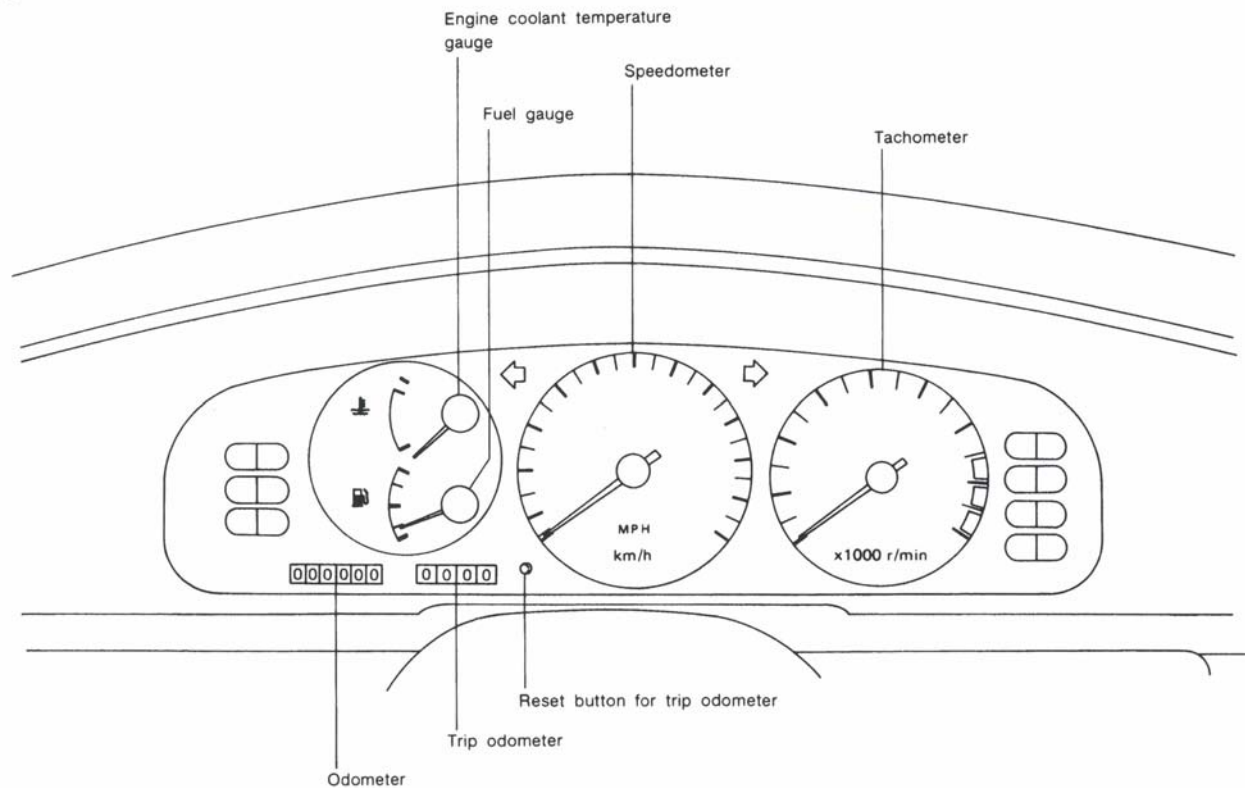

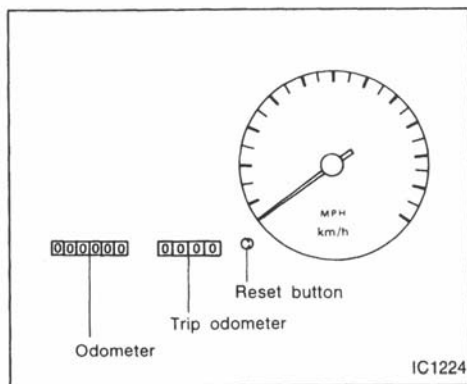

SPEEDOMETER

The speedometer indicates vehicle speed.

ODOMETER

The odometer records the total distance the vehicle has been driven.

TRIP ODOMETER

The trip odometer records the distance of individual trips. Before each trip, set the trip odometer to zero by pushing the RESET button.

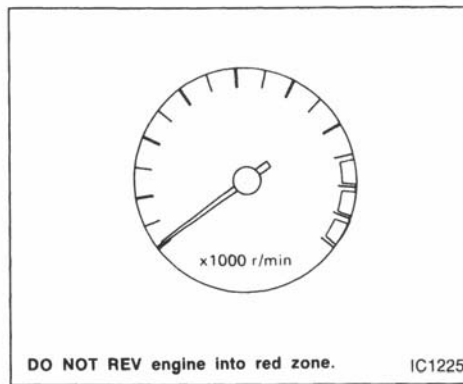

TACHOMETER

The tachometer indicates engine speed in revolutions per minute (r/min).

CAUTION:

When engine speed approaches the red zone, shift to a higher gear. Engine speed in the red zone may cause serious engine damage.

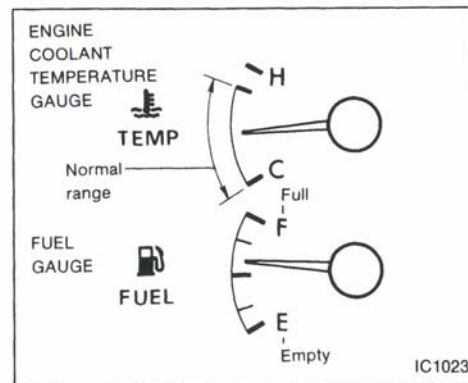

ENGINE COOLANT TEMPERATURE GAUGE

The gauge indicates the coolant temperature.

The coolant temperature will vary with the outside air temperature and driving conditions.

CAUTION:

If the gauge indicates over the normal range, stop the vehicle as soon as safely possible. If the engine is overheated, continued operation of the vehicle may seriously damage the engine. See "In case of emergency" section for immediate action required.

FUEL GAUGE











The gauge indicates the APPROXIMATE fuel level in the tank.

The gauge may move slightly during braking, turning, acceleration, or going up or down hill.

The gauge needle is designed to remain in approximately the same position, even when the ignition key is turned "OFF".

Refill the fuel tank before the gauge registers Empty.

WARNING/INDICATOR LIGHT AND CHIME

 or BRAKE	warning light		Low washer fluid warning light	CRUISE	CRUISE indicator light
	Turn signal/hazard indicator light	ABS	Anti-lock brake warning light	AIR BAG	Air bag warning light
	High beam indicator light (blue)	O/D OFF	Overdrive off indicator light	SECURITY	Theft warning light
	Charge warning light		Malfunction indicator light		
	Door open warning light		Engine oil pressure warning light		
	Seat belt warning light		Low fuel warning light		

Checking bulbs

Apply the parking brake and turn the ignition key to "ON" without starting the engine. The following lights will come on:

 ,  or BRAKE ,  , 

ABS

If any light fails to come on, it may indicate a burned-out bulb or an open circuit in the electrical system. Have the system repaired promptly.

Engine oil pressure warning light

This light warns of low engine oil pressure. If the light flickers or comes on during normal driving, pull off the road in a safe area, stop the engine **immediately** and call a NISSAN dealer or other authorized repair shop. **Running the engine with the oil pressure warning light on could cause serious damage to the engine.**

The oil pressure warning light is not de-

signed to indicate a low oil level. Use the dipstick to check the oil level. See "Engine oil" in the "Do-it-yourself operations" section.

Charge warning light

If the light comes on while the engine is running, it may indicate that there is something wrong with the charging system. Turn the engine off and check the alternator belt. If the belt is loose, broken, missing or if the light remains on, see your NISSAN dealer immediately.

CAUTION:

Do not continue driving if the belt is loose, broken or missing.

**Low fuel warning light**

This light comes on when the fuel in the tank is getting low. Refuel as soon as it is convenient, preferably before the fuel gauge reaches "E".

There should be a small reserve of fuel remaining in the tank when the fuel gauge needle reaches "E".

**Door open warning light**

This light comes on when any of the doors are not closed securely while the ignition key is "ON".

**Seat belt warning light and chime**

The light and chime remind you to fasten seat belts. The light flashes "ON" and "OFF" for about six seconds whenever the ignition key is turned to "ON". At the same time, the chime will sound for about six seconds unless the driver's seat belt is securely fastened.

Refer to Seat Belts section for AUTOMATIC SEAT BELT SYSTEM warnings.

**Air bag warning light**

When the ignition key is in the "ON" or "START" position, the air bag light will illuminate for about 7 seconds and then turn off. This means the system is operational.

If any of the following conditions occur, the air bag needs servicing and your vehicle must be taken to your nearest authorized NISSAN dealer.

1. The air bag light does not come on for 7 seconds and then go off as described above.
2. The air bag light flashes intermittently or remains on.
3. The air bag light does not come on at all.

Unless checked and repaired, the Supplemental Restraint System may not function properly. For additional details on the Air Bag System, see Section 2.

**Low washer fluid warning light**

This light comes on when the washer tank

fluid is at a low level. Add washer fluid as necessary. See the "Do-it-yourself operations" section.

**Brake warning light**

This light functions for both the parking brake and the foot brake systems.

Parking brake indicator

The light comes on when the parking brake is applied.

Low brake fluid warning

The light warns of a low brake fluid level. If the light comes on while the engine is running with the parking brake not applied, stop the vehicle and perform the following:

1. Check the brake fluid level. Add brake fluid as necessary. See "Brake and clutch fluid" in the "Do-it-yourself operations" section.
2. If the brake fluid level is correct, check the warning system.

WARNING:

- **If you judge it to be safe, drive carefully to the nearest service station for repairs. Otherwise, have your vehicle towed be-**

cause driving it could be dangerous.

- **Pressing the brake pedal when the engine stops and/or low brake fluid level may increase your stopping distance and require greater pedal effort as well as greater pedal travel.**

Anti-lock brake warning light

If the light comes on while the engine is running, it may indicate there is something wrong with the anti-lock portion of the brake system. Have the system checked by your Nissan dealer.

If an abnormality occurs in the system, the anti-lock function will cease but the ordinary brakes will continue to operate normally.

If the light comes on while you are driving, contact your NISSAN dealer for repair.

Overdrive off indicator light

This light comes on when the overdrive switch is pushed to the OFF  position.

Turn signal/hazard indicator lights

The light flashes when the turn signal

switch lever or hazard switch is turned on.

High beam indicator light (Blue)

This light comes on when the headlight high beam is on and goes out when the low beam is selected.

"CRUISE" indicator light

The light comes on while the vehicle speed is controlled by the cruise control system. If the light flickers while the engine is running, it may indicate there is something wrong with the cruise control system. Have the system checked by your NISSAN dealer.

Key reminder chime

The chime will sound if the driver side door is opened while the key is left in the ignition switch. Remove the key and take it with you when leaving the vehicle.

Light reminder chime

A chime will sound when the driver side door is opened if the light switch is turned on (ignition switch is turned off).

Turn the light switch off when you leave the vehicle.

Brake pad wear warning

The disc brake pads have audible wear warnings. When a brake pad requires replacement, it will make a high pitched scraping sound when the vehicle is in motion whether or not the brake pedal is depressed. Have the brakes checked as soon as possible if the warning sound is heard.

Malfunction indicator light

If this light comes on while the engine is running, it may indicate a potential emission control problem. Although the vehicle is still driveable, see your NISSAN dealer for service as soon as possible. Continued operation without having the emission control system checked and repaired as necessary could lead to poor driveability, reduced fuel economy, and possible damage to the emission control system which may affect your warranty coverage.

THEFT WARNING



The theft warning system provides visual and audio alarm signals if parts of the vehicle are disturbed.

How to activate the theft warning system

1. Remove the key from the ignition switch.
2. Close all windows. Close and lock all doors, hood and trunk lid. The doors can be locked either with or without the key.

The system can be activated even if the windows are open.

3. Confirm that the indicator light comes on. The light will glow for about 30 seconds and then go out. The system is now activated. If, during this 30 second time period, the door is unlocked or the ignition key is turned to "ACC" or "ON", the system will not activate.

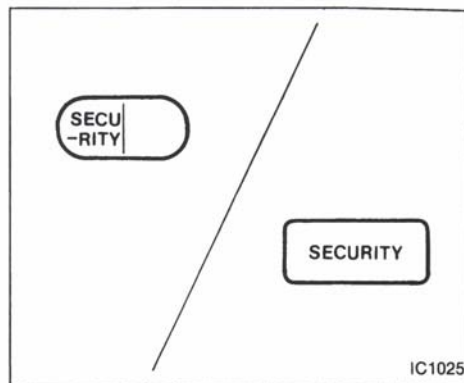

CAUTION:

- If the key is turned slowly when locking the door, the system may not activate. Furthermore, if the key is turned excessively to the unlock position, the system may be deactivated when the key is removed. If the indicator light fails to glow for 30 seconds, unlock the door once and lock it again.
- Even when the driver and/or passengers are in the vehicle, the system will activate with all doors, hood, trunk lid and back door locked and ignition key off.

Turn the ignition key to "ACC" or "ON" to turn the system off.

Theft warning system operation

The warning system will give the following alarm:

- The headlights blink and the horn sounds intermittently. In addition, the starter motor will not operate.
- The alarm automatically turns off after 2 to 4 minutes; however, the alarm will reactivate if the vehicle is tampered with again. The alarm can be shut off by unlocking a door or trunk lid with the key.

The alarm is activated by:

- Opening the door or trunk lid without using the key (even if the door is opened by releasing the door inside lock knob) or opening the trunk lid or back door by operating the opener lever.
- Opening the hood.
- Pushing in or pulling out of the key cylinder on the door or trunk lid.

How to stop alarms

The alarm will stop only by unlocking a door or trunk lid with the key. The alarm will not stop if the ignition switch is turned to "ACC" or "ON".

Digital touch entry system

To activate the theft warning system, close the hood and trunk. The door may be locked with or without the key or by pressing the "  " button.

To deactivate the system or turn off the alarm:

- Unlock the door with the key, or
- Unlock the door using the personal code number.

If the system does not operate as described above, have it checked by your NISSAN dealer.

WINDSHIELD WIPER AND WASHER SWITCH

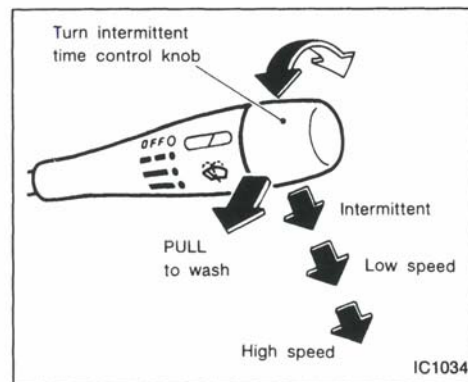

Push the lever down to operate the wiper. Pull the lever toward you to operate the washer.

Intermittent operation can be adjusted from 4 to 12 seconds by turning the knob.

CAUTION:

- Do not operate the washer continuously for more than 30 seconds.
- Do not operate the washer if the reservoir tank is dry.

REAR WINDOW DEFOGGER SWITCH

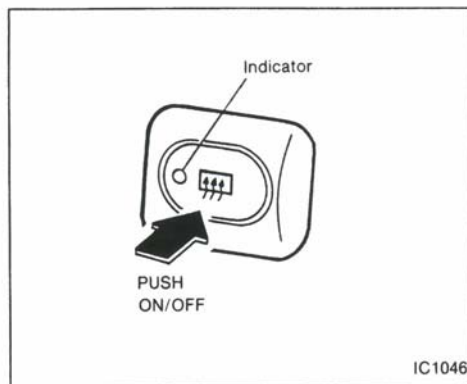

To defog the rear window glass, start the engine and push the switch on. (The indicator light will come on.) Push the switch again to turn the defogger off.

It will automatically turn off in approximately 15 minutes.

CAUTION:

When cleaning the inner side of the window, be careful not to scratch or damage the electrical conductors.

OUTSIDE MIRROR DEFOGGER SWITCH

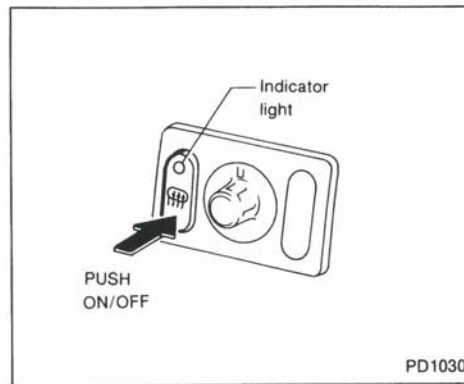

To defog the outside mirror glass, start the engine and push the switch on. The indicator light will come on. Push the switch off when the mirrors are clear.

HEADLIGHT AND TURN SIGNAL SWITCH

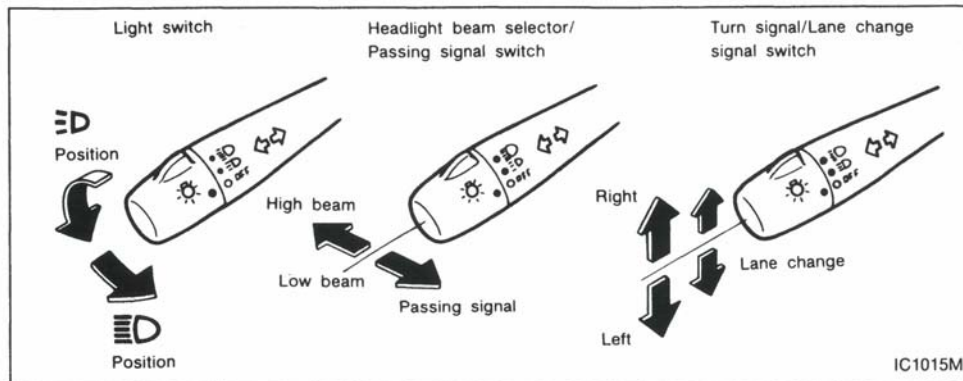

Lighting

Turn the switch to the "☰D" position:

The front clearance, side marker, tail, license plate and instrument lights will come on.

Turn the switch to the "☷D" position:

Headlights will come on and all the other lights remain on.

To select the high beam, push the lever forward. Pull it back to select the low beam.

Daytime light system (For Canada)

With the parking brake applied, the daytime light will not come on when the engine is started; the daytime light will come on when the parking brake is released. Thereafter, the daytime light will not turn off when using the parking brake at a stop signal, etc. The headlights illuminate a little darker than with the light switch in the "☷D" position.

WARNING:

When the daytime light system is active, tail lights on your vehicle will not be on. It is necessary at dusk to turn on your headlights. Failure to do so could cause an accident injuring yourself and others.

Passing signal

Pulling the lever toward you will turn on the headlight high beam.

Turn signal

Move the lever up or down to signal the turning direction. When the turn is completed, the turn signals cancel automatically.

Lane change signal

To indicate a lane change, move the lever up or down to the point where lights begin flashing.

CORNERING LIGHT

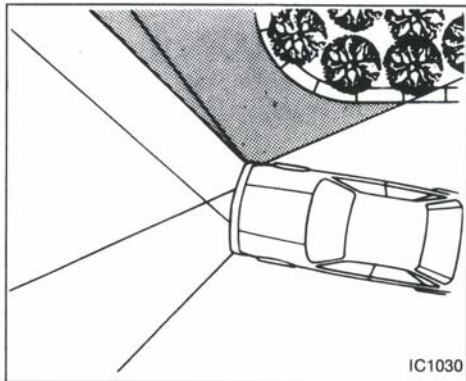

The cornering light provides additional illumination toward the turning direction. The light will come on when the turn signal lever is moved to the right or left with the headlights on.

INSTRUMENT BRIGHTNESS CONTROL



The instrument brightness control operates when the light switch is in the "⊞D" or "⊞D" position.

Keep pushing the control to adjust the brightness of instrument panel lights.

FRONT FOG LIGHT SWITCH

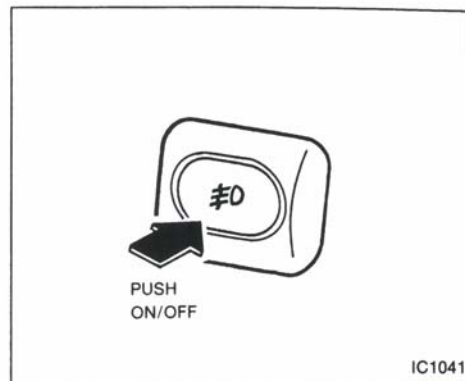

To turn the fog lights on, turn the headlight switch to the "⊞D" position, then push in the switch. To turn them off, push it again.

The headlights must be on for the fog lights to operate.

HAZARD WARNING FLASHER SWITCH

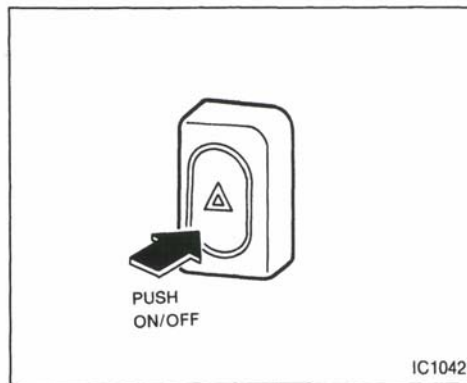

Push the switch on to warn other drivers when you must stop or park under emergency conditions. All turn signal lights will flash.

WARNING:

- **When stalled or stopped on the roadway under emergency conditions, move the vehicle well off the road.**
- **Do not use the switch while moving on the highway unless unusual circumstances force you to drive so slowly that your vehicle might become a hazard to other traffic.**

- **Some state laws may prohibit the use of the hazard warning flasher switch while driving.**
- **Turn signals do not work when the switch is operating.**

The flasher can be actuated with the ignition switch either off or on.

CIGARETTE LIGHTER AND ASH TRAYS

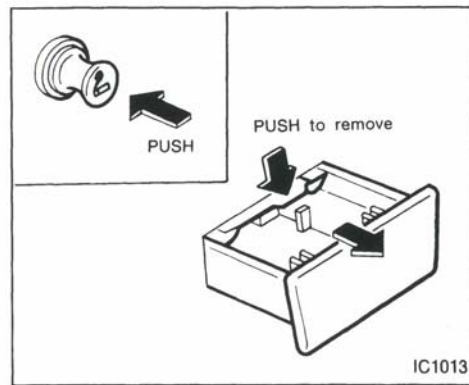

Push the lighter in all the way. When the lighter is heated, it will spring out.

Return the lighter to its original position after use.

POCKET AND CUP HOLDER

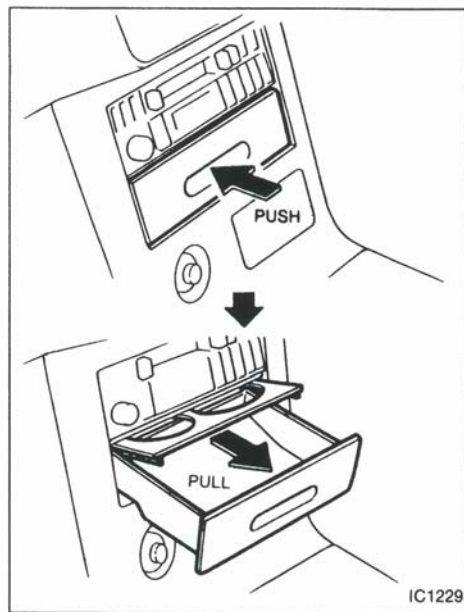
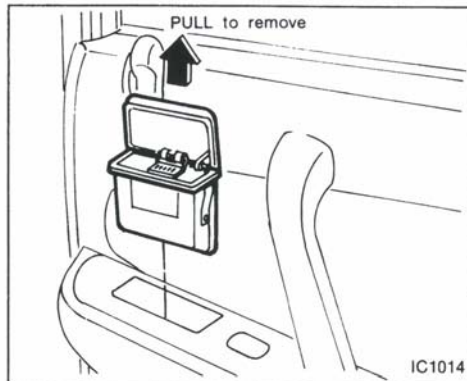

To open, push the pocket, then pull the cup holder.

To close, fully push the cup holder and pocket.

WARNING:

The pocket and cup holder should not be used while driving in order that full attention may be given to the driving operation.

POWER WINDOW

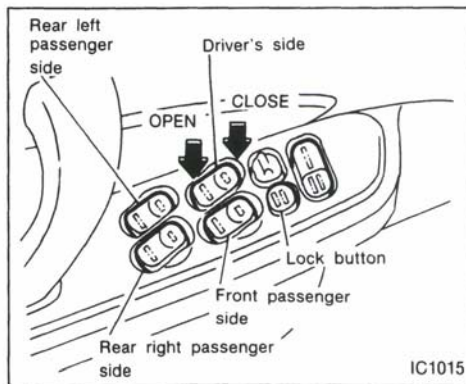

The power window only operates when the ignition key is in the "ON" position.

To open or close the window, press the switch and hold it down. The main switch (driver side switches) will open or close all the windows.

Locking passenger's window

When the lock button is pushed in, only the driver side window can be opened or closed. Push it in again to cancel.

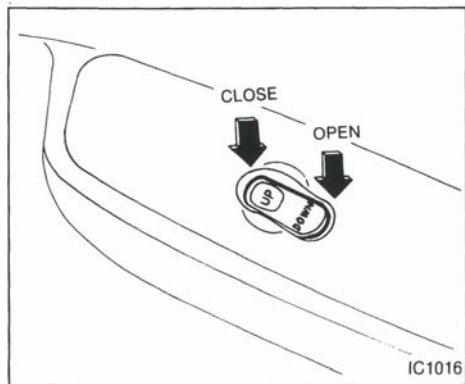

The passenger side switch will open or close only the corresponding window. To open or close the window, hold the switch down.

WARNING:

- **Make sure that all passengers have their hands, etc. inside the vehicle before closing the windows.**
- **Do not leave children unattended inside the vehicle. They could unknowingly activate switches.**

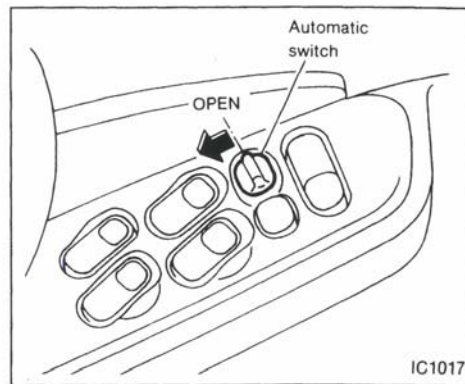

Power window automatic switch

To fully open the driver side window, press down the switch and release it; it need not be held. The window will automatically open all the way. To stop the window, press then release the "UP" side of the main switch.

SUN ROOF

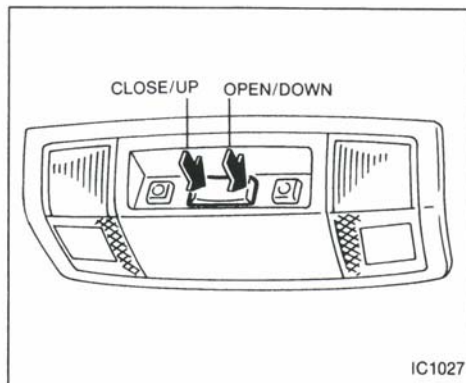

The sun roof will only operate when the ignition key is in the "ON" position.

Sliding the sun roof

To open the roof, hold down the "OPEN" side of the switch.

To close the roof, hold down the "CLOSE" side. The roof will stop at approximately 4 in (100 mm) from the fully closed position. Then, release the switch and push down again to fully close the sun roof. This feature helps to reduce the chance of pinching your fingers.

Tilting the sun roof

To tilt up, first close the sun roof, then keep pushing the "UP" side of the tilt switch. To close the sun roof, keep pushing the "DOWN" side.

Sun shade

Open and close the sun shade by sliding it forward or backward.

WARNING:

- Be extremely careful not to have any part of your body in the sun roof opening while it is closing.
- Do not stand up or extend any portion of your body out of the opening while driving.
- Remove water drops, snow, ice or sand from the sun roof before opening.
- Do not place any heavy object on the sun roof or surrounding area.

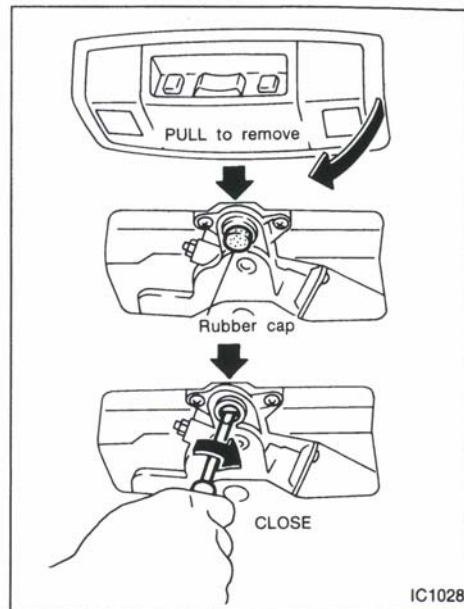

IF THE SUN ROOF DOES NOT CLOSE

CAUTION:

Turn the ignition key off.

CLOCK

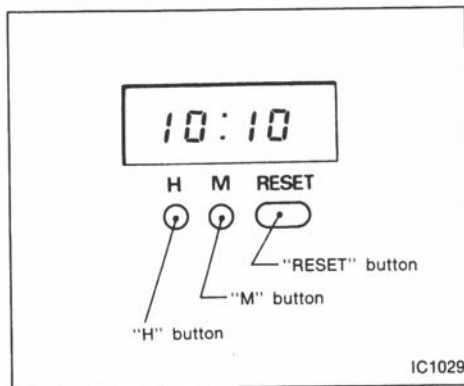

1. Remove the spot light unit. The shaft end of the sun roof motor will be found under the rubber cap.
2. Remove the rubber cap.
3. Using a screwdriver, push the center of the shaft end and turn the shaft clockwise to close the sun roof.

Have the sun roof system checked and repaired by your NISSAN dealer.

The digital clock displays time when the ignition key is in "ACC" or "ON".

If the power supply is disconnected, the clock will not indicate the correct time. Readjust the time.

Adjusting the time

Push the **H** button to adjust the hour.

Push the **M** button to adjust the minute.

Resetting the time

To reset the time to a radio time signal, push the **Reset** button.

For example, if the **Reset** button is depressed while the time is between 8:00 and 8:29, the display will be reset to 8:00. If depressed while it is between 8:30 and 8:59, the display will be reset to 9:00.

INTERIOR LIGHT

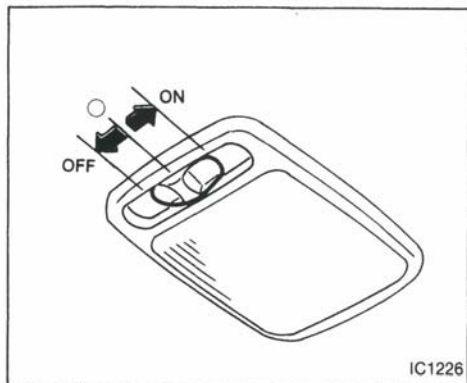

The interior light has a three-position switch.

When the switch is in the center "○" position, the light will illuminate when a door is opened.

Interior light delay system

On models equipped with this system, when the light switch is set at the center "○" position, the interior light will gradually fade out after the driver side door is closed.

Illuminated entry system (For models without digital touch entry system)

On models equipped with this system, when the light switch is set at the center "○" position and the driver side door handle is pulled and released once, the interior light and door key light will come on and gradually go out. This system is helpful at night to locate the door key slot or check the vehicle interior.

FRONT PERSONAL LIGHT

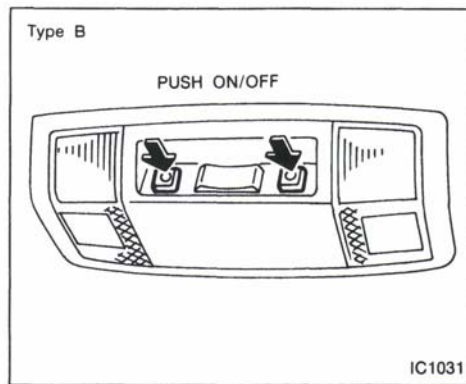
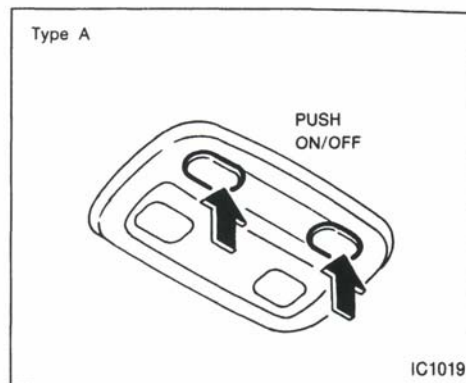

MEMO

MEMO

2 Pre-driving checks and adjustments

[Locks]

Key	2-2
Door locks.....	2-2
Digital touch entry system	2-4
Hood release	2-6
Glove box lock.....	2-7
Trunk lid lock.....	2-7
Fuel filler lid lock	2-8
Supplemental restraint system (Air bag system)	2-10

[Seats]

Seats	2-13
Seat belts	2-16
Tilting steering wheel	2-31

[Mirrors]

Outside mirrors	2-32
Inside mirror.....	2-33

KEY

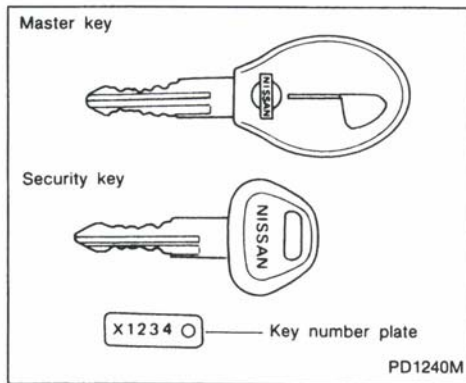

The master key can be used for all the locks. The security key cannot be used for the trunk lid or glove box locks. To protect belongings when you leave a key with someone, give them the security key only.

Record the key number on the key number plate and keep it in a safe place (such as your wallet), NOT IN THE CAR. A key number plate is supplied with your key. Keep the plate in a safe place. If you lose your keys, see your NISSAN dealer for duplicates by using the key number.

DOOR LOCKS

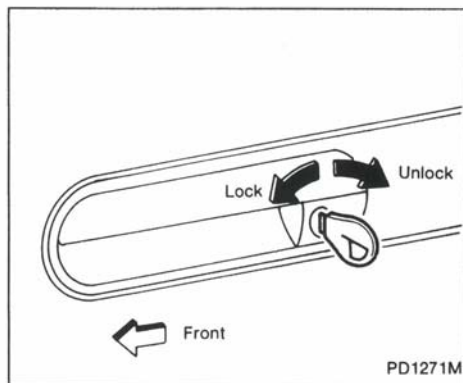

Locking front doors with key

To lock the door, turn the key towards the front of the vehicle.

To unlock, turn it towards the rear.

Locking the front door will simultaneously lock the other doors.

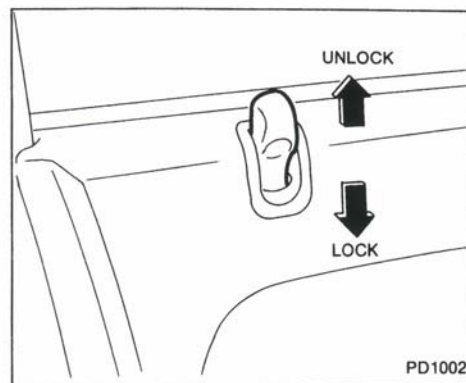

Locking the doors without key

To lock from the outside without a key, move the inside lock knob to the "LOCK" position. Then close the door.

The inside lock knob cannot be set to the "LOCK" position with the front doors open and with the key in the ignition.

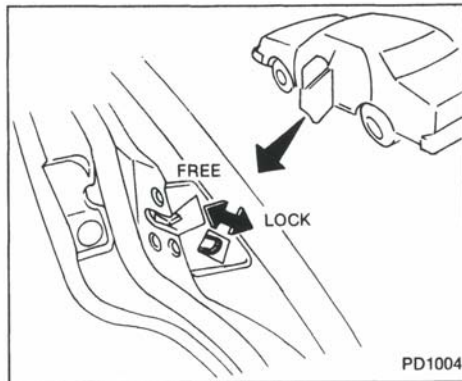

CHILD SAFETY REAR DOOR LOCK

Child safety locking helps prevent doors from being opened accidentally, especially when small children are in the vehicle.

When the lever is in the lock position, the rear door can be opened only from the outside.

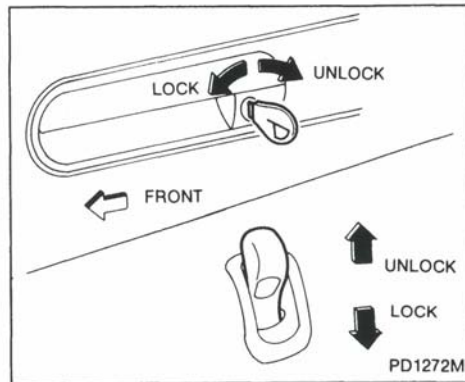

POWER DOOR LOCK

The power door lock system allows you to lock or unlock all doors simultaneously.

- Turning the front door key to the front of the vehicle will lock all doors.
- Turning the front door key one time to the rear of the vehicle will unlock the corresponding door. From that position, returning the key to Neutral (where the key can only be removed and inserted.) and turning it to the rear again will unlock all doors.

CAUTION:

- Always have the doors locked while driving. Along with the use of seat belts, this provides greater safety in the event of an accident by helping to prevent persons from being thrown from the vehicle. This also helps keep children and others from unintentionally opening the doors, and will help keep out intruders.
- Before opening any door, always look for and avoid oncoming traffic.

DIGITAL TOUCH ENTRY SYSTEM

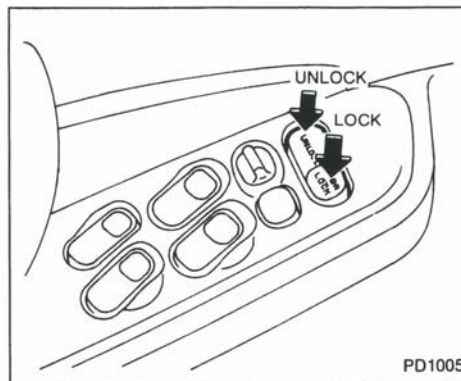

- Pushing the front door lock knob down will lock all doors.

- Operating the lock-unlock switch will lock or unlock all doors.

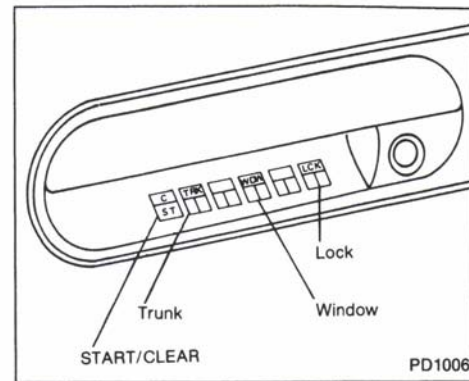

The digital touch entry system allows operation of all locks without using a key. The system is operated by the push buttons located under the driver side or passenger side door handles.

The ignition key will operate any lock without using the digital touch entry system.

Coding system

The system is operated by two sets of numbers:

Fixed number:

A 7-digit number used only to enter or

change your personal CODE NUMBER. This number cannot be altered, and applies only to your vehicle. Your NISSAN dealer will give you a fixed number plate. It is a good idea to keep it in your wallet/purse together with your license.

Code number:

A personal 4- to 7-digit number you select and program into the digital touch entry system. It is used to unlock doors, the trunk lid or for opening the front window and the sun roof.

How to enter code number

There are two numbers on each button. Only one number is entered into the digital touch entry system each time an individual button is pressed.

For example, the code number "1 6 8 3 4" can be entered by pushing the buttons as follows:



1. Press the start/clear (

C	ST
---	----

) button.
2. Enter the 7-digit FIXED NUMBER. A beep will sound for 6 seconds.

3. Enter a 4- to 7-digit personal CODE NUMBER while the beep is sounding.
4. After the personal CODE NUMBER is entered, the beep will sound at short intervals. This indicates successful entry of the personal CODE NUMBER.

If wrong numbers are entered, the beep will not sound. Press the start/clear (

C	ST
---	----

) button, then enter a correct personal CODE NUMBER.

The following numbers cannot be entered as CODE NUMBER;

- Any number where all digits are on the same button.
EXAMPLE: 1-2-1-2, 3-3-4-4
- Any number requiring sequential operation of the buttons.
EXAMPLE: 1-3-5-7 or 7-5-3-1
- Any number with 3 or fewer digits.
- Any number with eight or more digits. Continuously pushing random buttons will cause the system to stop functioning for 6 to 30 seconds.

Unlocking doors, trunk, or opening the front windows and the sun roof

1. Press the start/clear (

C	ST
---	----

) button.
2. Enter your personal CODE NUMBER (4 to 7 digits). All doors will unlock.
3. Press the window (

WDW	56
-----	----

) button to open the front windows and the sun roof.
4. Press the trunk (

TRK	12
-----	----

) button to unlock the trunk lid.

If the keypads are depressed in any wrong combination 24 or more times, the anti-theft circuitry will turn the keypad lights/beeper off the 6 seconds. In addition, if the keypads are depressed in any wrong combination 80 or more times, the anti-theft circuitry will turn the keypad lights/beeper off for 30 seconds.

**Before leaving the vehicle, be sure to press the lock (

LCK	90
-----	----

) button and check to see that all doors are locked.**

Locking doors and trunk lid

Remove the key from the ignition switch, close all doors and trunk lid and push the lock (

LCK	90
-----	----

) button. All doors will lock.

HOOD RELEASE

Operating tips

- A warning buzzer will sound if the lock () button is pressed when the key is left in the ignition or any of the doors are open.
- If the battery is disconnected for about 20 days, this may cancel the memorized personal CODE NUMBER. In that case, enter the personal CODE NUMBER again.
- If trouble occurs in the digital touch entry system, or if the fixed number plate is lost, contact your NISSAN dealer.

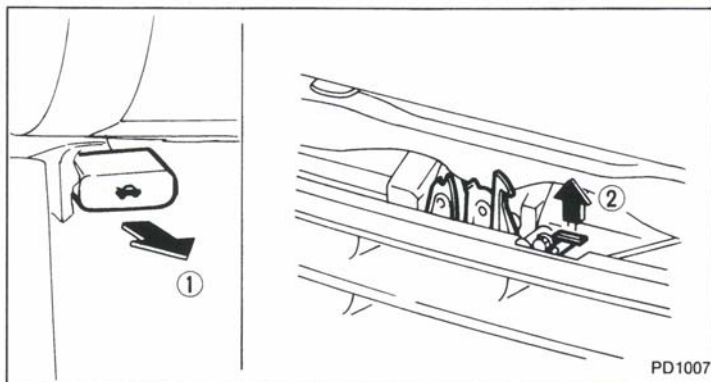

1. Pull the hood lock release handle ① located below the instrument panel; the hood will then spring up slightly.
2. Pull the lever ② at the front of the hood with your fingertips and raise the hood.
3. When closing the hood, slowly close the hood and make sure it locks into place.

GLOVE BOX LOCK

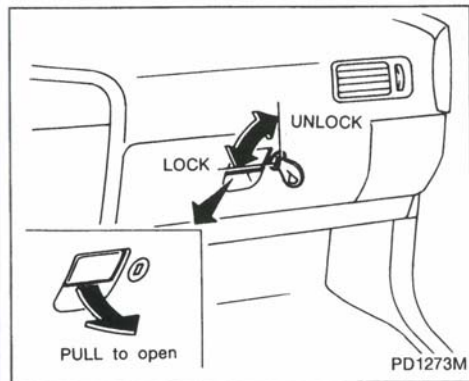

When locking or unlocking the glove box, use the master key.

The glove box may be opened by pulling the handle.

WARNING:

Keep glove box lid closed while driving to prevent injury in an accident or a sudden stop.

TRUNK LID LOCK

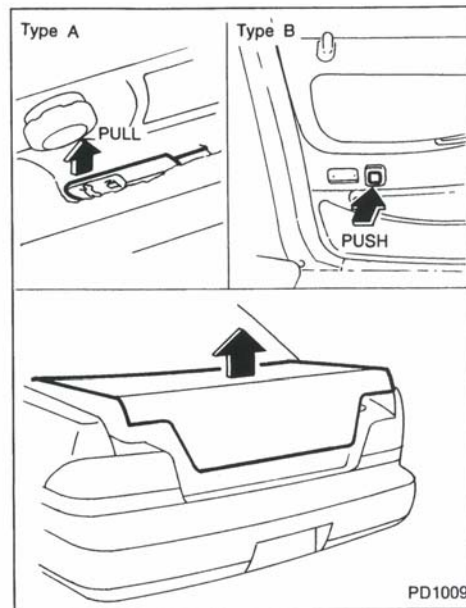

Trunk lid release operation

The trunk lid release lever is located on the outside of the driver's seat. To open the trunk lid, pull up the trunk lid release lever. To close, push the trunk lid down securely.

Trunk lid release switch operation

The trunk lid release switch is located under the driver's arm rest.

To open the trunk lid, push the release switch. To close, push the trunk lid down securely.

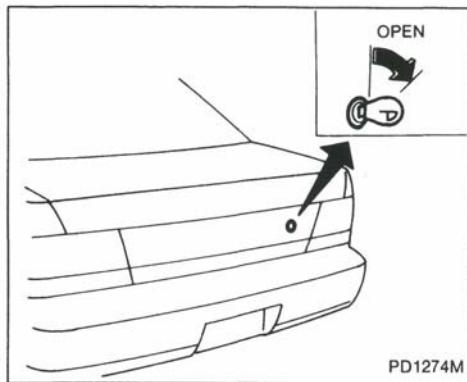

Key operation

To open the trunk lid, turn the key clockwise. To close, lower and push the trunk lid down securely.

WARNING:

Do not drive with the trunk lid open. This could allow dangerous exhaust gases to be drawn into the vehicle.

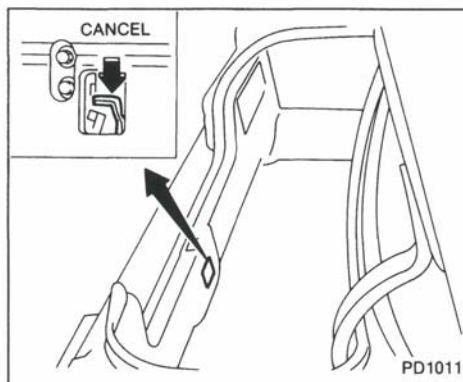

OPENER CANCEL LEVER FOR TRUNK LID

When the lever is in the "CANCEL" position, the trunk lid cannot be opened with the trunk lid release lever or switch. It can be opened only with the key.

FUEL FILLER LID LOCK

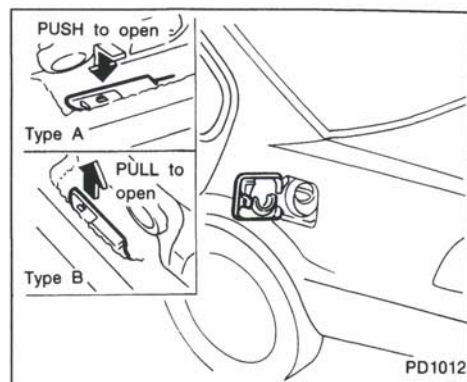

Opener lever

Type A

To open the fuel filler lid, move the opener lever toward the center of the vehicle and push it down. To lock, close the fuel filler lid securely.

Type B

To open the fuel filler lid, pull the opener lever. To lock, close the fuel filler lid securely.

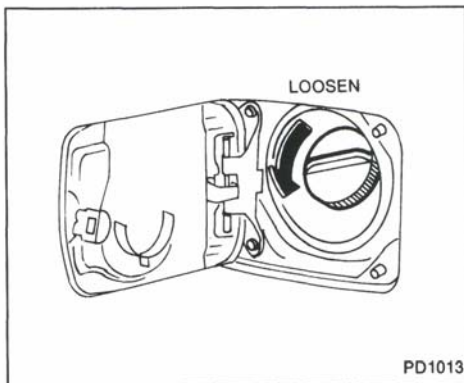

FUEL FILLER CAP

The fuel filler cap is a screw-on ratcheting type. Tighten the cap clockwise until ratcheting clicks are heard.

CAUTION:

- Gasoline is extremely flammable and highly explosive under certain conditions. Always stop engine and do not smoke or allow open flames or sparks near the vehicle when refueling.

- Fuel may be under pressure. Remove cap slowly to prevent fuel from spraying out and possible personal injury.
- Use only a genuine NISSAN fuel filler cap as a replacement. It has a built-in safety valve needed for proper operation of the fuel system and emission control system. An incorrect cap can result in a serious malfunction and possible injury.

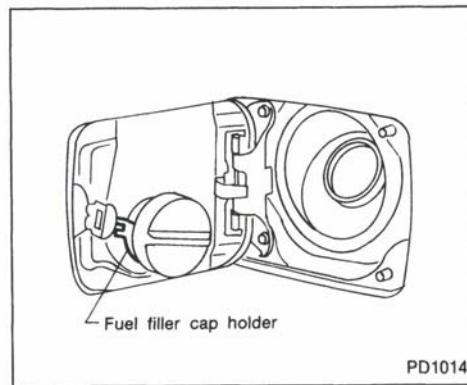

Put the fuel filler cap on the cap holder while refueling.

SUPPLEMENTAL RESTRAINT SYSTEM (AIR BAG SYSTEM)

The information written in this Supplemental Restraint System section contains important points concerning the air bag system installed in some MAXIMA models to help reduce impact force to the driver in certain frontal collisions. The air bag is designed to **supplement** the accident protection provided by the driver's seat belt and is **not a substitute** for the three-point seat belt system. The seat belt should be correctly worn and the driver seated a suitable distance from the steering wheel.

The air bag will operate only when the ignition switch is in the "ON" or "START" position.

WARNING:

The seat belts are designed to help reduce the risk or severity of injury in various kinds of accidents and should be worn by all occupants of the vehicle. The seat belt must be worn, as the air bag only assists in reducing the impact force in a frontal collision. (See "Seat belts".)

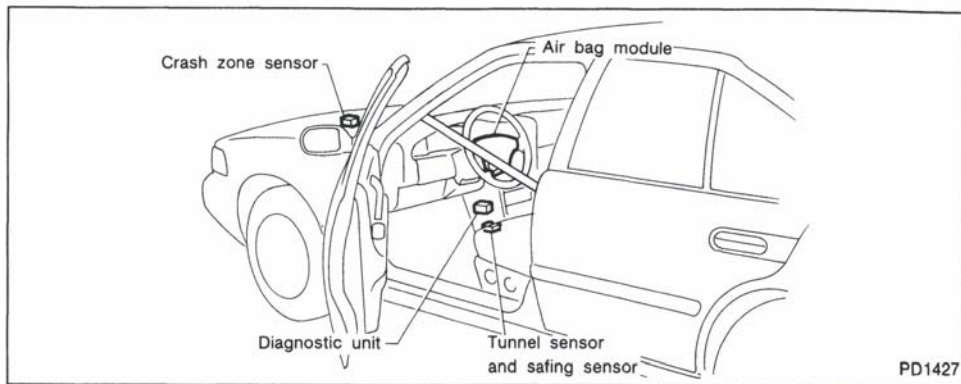

Air bag system

The air bag is located in the center of the steering wheel and will deploy in a moderate to severe frontal collision. The air bag will not usually deploy in the event of a side impact, rear impact or a roll-over accident. There are no air bags for the passenger seat. When the air bag system receives a signal from the crash zone sensors, a fairly loud deploying noise will be heard, followed by release of smoke. This smoke is not injurious and does not indicate a fire. The air bag, along with the use of a seat

belt, helps to cushion the impact force on the driver's face and chest. The seat belt should be correctly worn and the driver seated a suitable distance from the steering wheel. Since the air bag deploys quickly in order to protect the driver, the force of the air bag deploying can increase the risk of injury if the driver is too close to or is against the steering wheel during deployment. The air bag will deflate quickly after the collision is over.

The air bag will operate only when the ignition switch is in the "ON" or "START" position.

AIR BAG WARNING LIGHT

WARNING:

- Right after inflation, several air bat system components will be hot. Do not touch them, you may severely burn yourself.
- No unauthorized changes are to be made to any components or wiring of the air bag system. This is to prevent accidental deployment of the air bag or damage to the air bag operation. Tampering with the air bag system may result in serious personal injury. This includes changes to or replacement of the steering wheel, placing material over the steering wheel pad, or installing additional trim material around the air bag system. Objects attached to the steering wheel pad may become dangerous projectiles and cause injury if the air bag deploys. Work around and on the air bag system should be done by an authorized NISSAN dealer. (The yellow SRS wiring must not be disconnected.) Installation of electrical equipment should also be done by an authorized NISSAN dealer. Unauthorized electrical test equipment and probing devices must not be used on the air bag system.

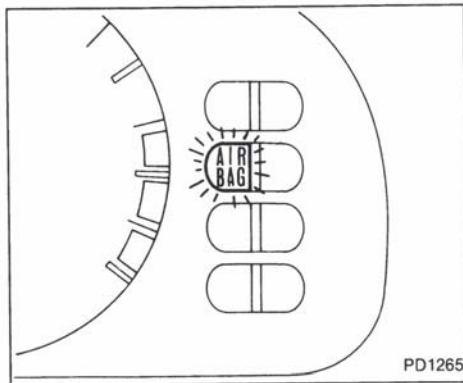

The air bag light, displaying "AIR BAG" in the instrument panel, monitors the circuits of the air bag. The circuits monitored by the air bag light are the crash zone sensor, tunnel sensor, safing sensor and all related wiring.

When the ignition key is in the "ON" or "START" position, the air bag light will illuminate for about 7 seconds and then turn off. This means the system is operational.

If any of the following conditions occur, the air bag needs servicing and must be taken to your nearest authorized NISSAN dealer.

1. The air bag light does not come on for 7 seconds and then go off as described above.
2. The air bag light flashes intermittently or remains on.
3. The air bag light does not come on at all.

Under these conditions, the Supplemental Restraint System Air Bag will not operate properly. It must be checked and repaired.

Repair and replacement procedure

The air bag system is designed to inflate on a one-time-only basis. As a reminder unless it is damaged, the air bag light will remain illuminated after deployment has occurred. Repair and replacement of the air bag system must be done only by an authorized NISSAN dealer. To ensure long-term functioning, the system must be inspected 10 years after the date of manufacture as noted on the F.M.V.S.S. certification label located on the driver side center pillar.

When maintenance work is required on the vehicle, the air bag system and related parts should be pointed out to the person conducting the maintenance. The ignition key must always be in the "LOCK" position

AIR BAG INFORMATION AND WARNING LABELS

when working under the hood or inside the vehicle.

WARNING:

- Once the air bag is deployed, the air bag module will not function again and must be replaced. The air bag module cannot be repaired.
- The air bag system must be serviced by an authorized NISSAN dealer if there is any damage made to the front end portion of the vehicle or if the air bag has deployed.
- When selling your vehicle, we request you inform the buyer about the air bag system and guide the buyer to the appropriate sections in this Owner's Manual.
- If you need to dispose of the air bag or scrap the vehicle, contact an authorized NISSAN dealer. Correct air bag disposal procedures are set forth in the appropriate NISSAN Service Manual. Incorrect disposal procedures could cause personal injury.

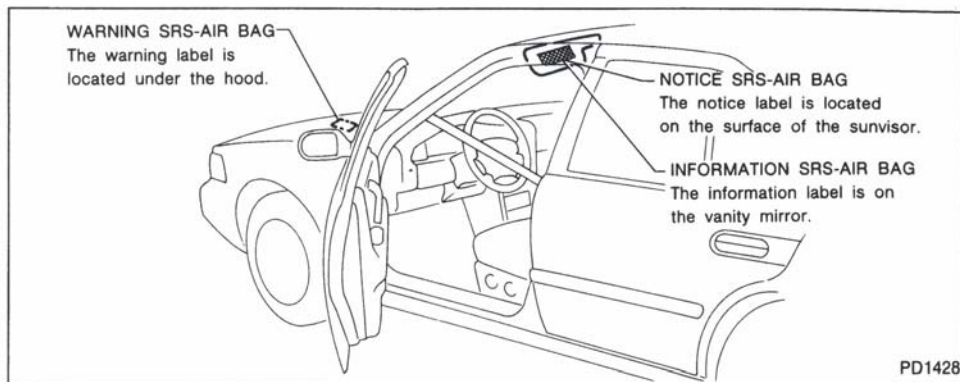

Information and warning labels about the air bag system are placed in the vehicle.

SEATS

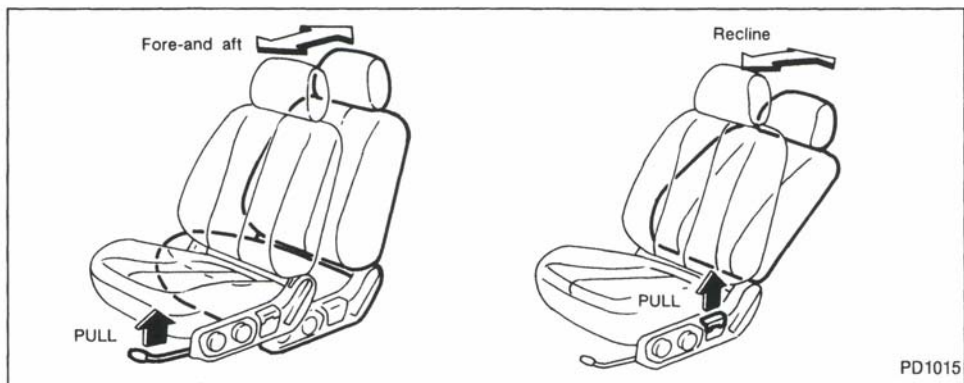

SEAT ADJUSTMENT

WARNING:

- Do not adjust the driver's seat while driving. The seat may move suddenly and could cause loss of control of the vehicle.
- After adjustment, gently rock in the seat to make sure it is securely locked.

Fore-and-aft

Pull the lever up while you slide the seat forward or backward to the desired posi-

tion. Release the lever to lock the seat in position.

Reclining

Pull the lever up and lean back until the desired angle is obtained. To bring the seat back forward again, pull the lever and move your body forward. The seat back will move forward.

WARNING:

The seatback should not be reclined any more than needed for comfort. Seat belts are most effective when the passenger sits well back and straight up in the seat. If the seat is reclined, the risk of sliding under the lap belt and being injured is increased.

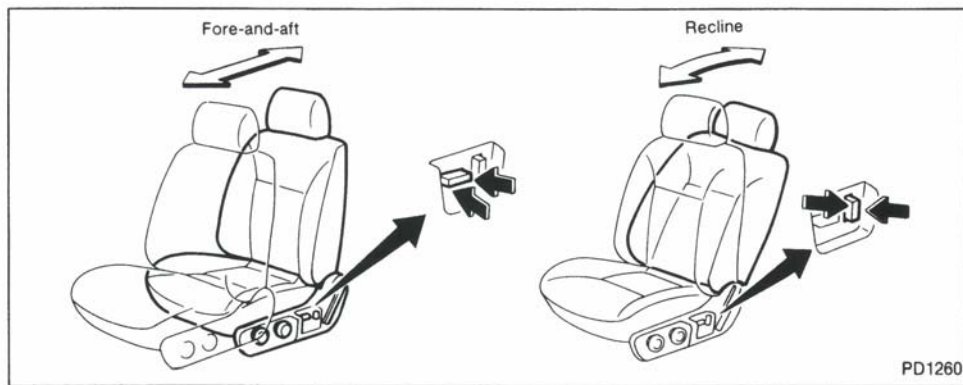

POWER SUPPORT SEAT

WARNING:

- Do not adjust the driver's seat while driving.
- The seatback should not be reclined any more than needed for comfort. Seat belts are most effective when the passenger sits well back and straight up in the seat. If the seat is reclined, the risk of sliding under the lap belt and being injured is increased.

- Do not leave children unattended inside the vehicle. They may inadvertently activate switches.

Operating tips

- The motor has an auto-reset overload protection circuit. If the motor stops during operation, wait 30 seconds, then reactivate the switch.
- Do not operate the power support seat for a long period of time when the engine is off. This will discharge the battery.

Fore-and-aft

Move the switch forward or rearward while sliding the seat forward or rearward to the desired position.

Reclining

Move the switch rearward until the desired angle is obtained. To bring the seat back forward again, move the switch forward and move your body forward. The seat back will move forward.

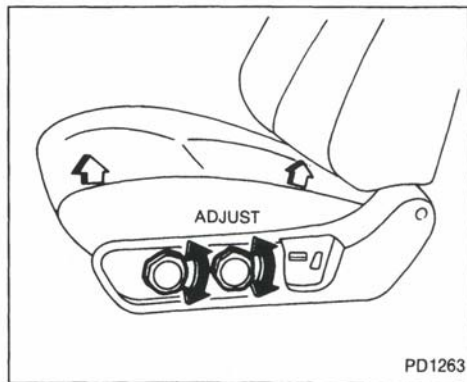

Seat lifter

Turn either dial to adjust the angle and height of the seat to the desired position.

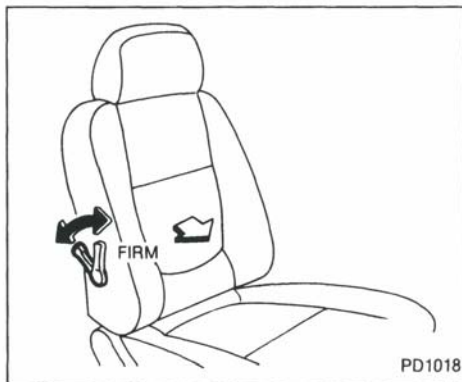

Lumbar support

Turn the lever forward or backward to adjust the seat lumbar area.

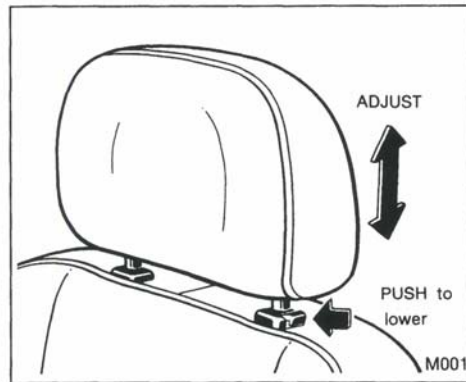

HEAD RESTRAINT

Adjust the top of the head restraints level with the top of your ears.

To raise the head restraint, just pull it up. To lower, push the lock knob and push the head restraint down.

WARNING:

Head restraints should be adjusted properly as they may provide significant protection against whiplash injury. Do not remove them.

SEAT BELTS

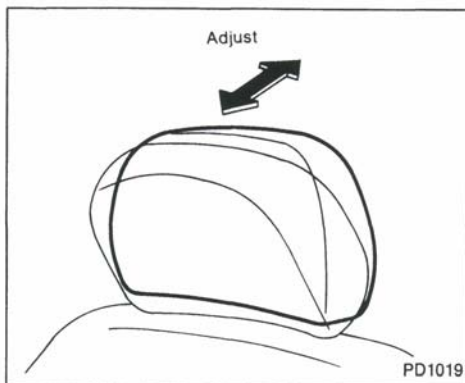

To adjust the head restraint, push it forward or rearward as shown (If so equipped).

PRECAUTIONS ON SEAT BELT USAGE

Your chances of being injured in an accident and/or the severity of injury may be greatly reduced if you are wearing your seat belt and it is properly adjusted. NISSAN strongly encourages you and all of your passengers to buckle up every time you drive.

Some states, provinces or territories require that seat belts be worn at all times when a vehicle is being driven.

WARNING:

- The belt should be adjusted to a snug fit. Slack in the lap-shoulder belt will reduce the effectiveness of the entire restraint system.
- Never wear the belt inside out or twisted.
- Do not allow more than one person to use the same belt.
- All seat belt assemblies including retractors and attaching hardware should be inspected after any collision at your NISSAN dealer. NISSAN recommends that all seat belt assemblies in use during a collision be replaced unless the collision

was minor and the belts show no damage and continue to operate properly. Seat belt assemblies not in use during a collision should also be inspected and replaced if either damage or improper operation is noted.

Be sure to observe the following cautions when using seat belts. Failure to do so could increase the chance and/or severity of injury in an accident.

- Always pass the shoulder belt over your shoulder and across your chest. Never run the belt under your arm. Serious injury can occur if seat belt is not worn properly.
- Position the lap belt as low as possible **AROUND THE HIPS, NOT THE WAIST.**

Infant or small child

Nissan recommends that infants or small children be seated in a child restraint system. You should choose a child restraint system which fits your vehicle and always follow the manufacturer's instructions for installation and use.

Children

Children who are too large for child re-

straint systems should be seated and restrained by the seat belts which are provided.

NISSAN recommends that children sit in the rear seat if available. According to accident statistics, children are safer when properly restrained in the rear seat than in the front seat.

If the child's seating position has a shoulder belt that fits close to the face or neck, the use of a booster seat (commercially available) may help overcome this. The booster seat should raise the child so that the shoulder belt is properly positioned across the top, middle portion of the shoulder and the lap belt is low on the hips. The booster seat should fit the vehicle seat and have a label certifying that it complies with Federal Motor Vehicle Safety Standards or Canadian Motor Vehicle Safety Standards. Once the child has grown so the shoulder belt is no longer on or near the face and neck, use the shoulder belt without the booster seat.

Never let a child stand or kneel on any seat and do not allow a child in the cargo areas while the vehicle is moving.

Pregnant women

Nissan recommends that pregnant women use seat belts. Contact your doctor for specific recommendations. The lap belt should be worn snug and positioned as low as possible around the hips, not the waist.

Injured persons

Nissan recommends that injured persons use seat belts, depending on the injury. Check with your doctor for specific recommendations.

AUTOMATIC SEAT BELT SYSTEM (For U.S.A.)

The Automatic Seat Belt system consists of an automatic shoulder belt and a manual lap belt for the driver and front passenger seat positions. The shoulder belts automatically adjust to the body and seating positions when the door is closed and the ignition key is turned "ON".

WARNING:

- For most effective protection, always fasten the manual lap belt in addition to the automatic shoulder belt.
- To properly operate the automatic seat

belt system, the shoulder belt tongue should always remain inserted in the shoulder belt buckle, located in the rail of the door opening.

NISSAN recommends that children be seated in the rear seats. See Precautions on Seat Belt Usage earlier in this Section.

System malfunction

If, while the ignition switch is turned "ON" with either front door open, the seat belt warning light flickers and the chime sounds faster than usual for about 6 seconds, it may indicate a malfunction in the system. Have the system checked by your NISSAN dealer.

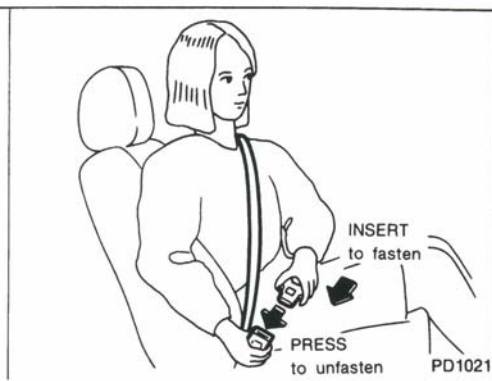
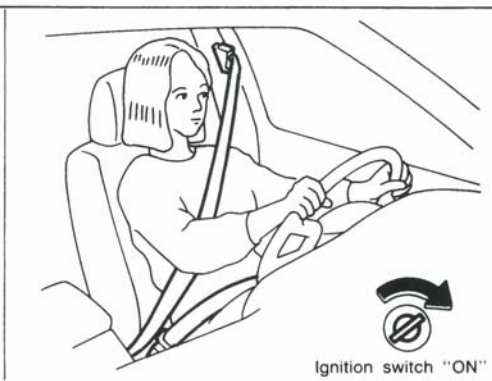
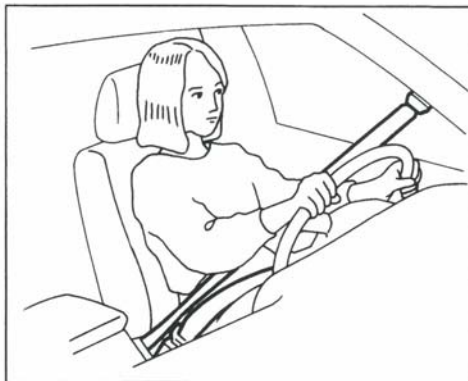

Fastening the belts

1. Open the door and make sure that the shoulder buckle is in the forward position. Then get into the vehicle and close the door.

If the ignition switch is in the "ON" position, the shoulder buckle will move to the rear position when closing the door.

2. Adjust the seat.

The seatback should not be reclined any more than needed for comfort. Seat belts are most effective when the passenger sits

well back and straight up in the seat. If the seat is reclined, the risk of sliding under the lap belt and being injured is increased.

3. Turn the ignition switch ON. The shoulder buckle will move to the rear position and will fit across your chest. Pull the shoulder belt toward the retractor to take up extra slack.

- Do not touch the door guide rail while the shoulder buckle is moving.
- Do not wear the shoulder belt across the neck or under your outer arm. The shoulder belt should be positioned mid-

way over the shoulder for the most effective protection.

4. Slowly pull the lap belt out of the retractor and insert the tongue into the lap buckle until it snaps. Position the lap belt **low on the hips** and pull the belt toward the retractor to take up extra slack.

- Do not wear the lap belt across the shoulder belt.
- The retractors are designed to lock during a sudden stop or on impact. A slow pulling motion will permit the belt to move, and allow you some freedom of

movement in the seat.

Unfastening the belts

1. To unfasten the lap belt, press the button on the lap buckle. The seat belt will automatically retract.
 2. Open the door. The shoulder belt buckle will move to the forward position and the shoulder belt will move away from your chest.
- **Do not touch the door guide rail while the shoulder buckle is moving.**
 - **Do not unfasten the shoulder belt tongue from the buckle except in emergency. See "Operation in emergency" later in this Section.**

How the automatic shoulder belt works

While the ignition switch is on:

The shoulder buckle will move to the forward position when the door is opened, and it will move to the rear position when the door is closed.

While the ignition switch is off:

The shoulder buckle will remain or move to

the front position when the door is opened, and it will remain in the front position when the door is closed until the ignition switch is turned "ON".

If the shoulder buckle operates abnormally, have the system checked by your NISSAN dealer.

Seat belt warning light "  " and warning chime

When the ignition switch is turned on with the door open (the shoulder buckle is at the front position):

The chime will sound for about 6 seconds, and the warning light will flicker continuously. The warning light will go off when the door is closed and the shoulder buckle reaches the rear position.

When the ignition switch is turned on with the door closed:

The chime will sound and the warning light will flicker until the shoulder buckle reaches the rear position. The warning light will come on for several seconds after the shoulder buckle reaches the rear position.

If the shoulder belt tongue is disconnected from the buckle:

When the ignition switch is turned on and the shoulder buckle reaches the rear position, the warning light will come on for about 100 seconds and the chime will sound for about 6 seconds until the shoulder belt is connected to the shoulder buckle. Insert the shoulder belt tongue into the shoulder buckle before driving.

If the driver side lap belt is not fastened:

When the ignition switch is turned ON and the shoulder buckle reaches the rear position, the warning light will come on for about 6 seconds and the chime will sound for about 6 seconds until the lap belt is fastened. Fasten the lap belt before driving.

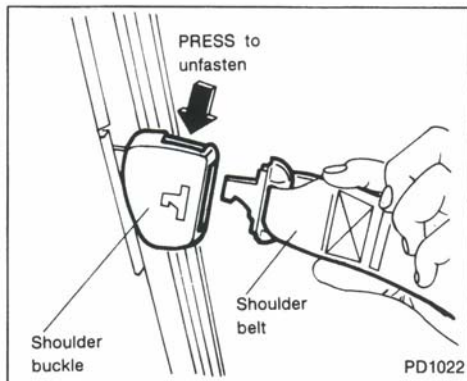

Operation in an accident

Emergency release

If you need to release the shoulder belt from the shoulder belt buckle in an emergency, press the buckle marked with "PRESS EMERGENCY". Use this feature only when the shoulder belt keeps you from leaving the vehicle in an accident.

For normal use, the shoulder belt should always be connected to the buckle.

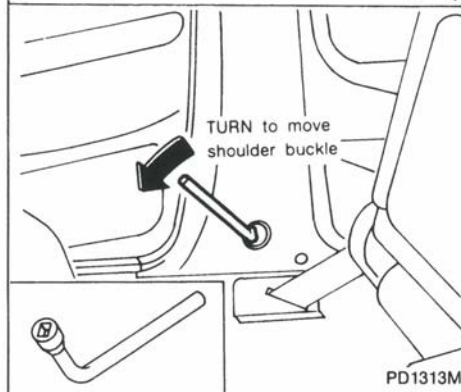
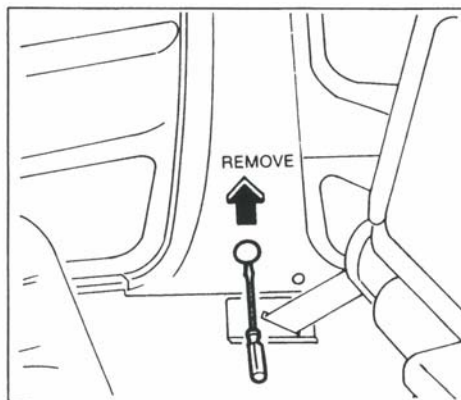

Manual operation

If either shoulder belt buckle does not operate

1. Slide the seat forward as far as possible.
2. Remove the blind cap in the lower portion of the center pillar with the screwdriver. The shaft end of the motor will be visible.
3. Using the wrench supplied in the tool bag, turn the shaft of the motor counter-clockwise to move the shoulder buckle to the rear position.

Have the automatic seat belt system checked and repaired by your NISSAN dealer.

Checking seat belt retractor operation(Automatic seat belt)

Your seat belt retractors are designed to lock belt movement **only** when the vehicle slows down rapidly. Pulling on the belt will not cause the retractor to lock, no matter how fast you pull.

If you wish to have the locking operation of your seat belts checked for you, or if you have any question about belt operation, see your NISSAN dealer.

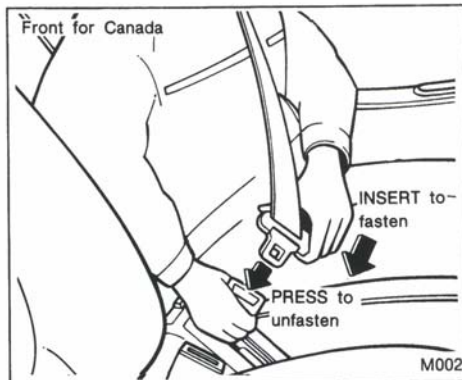

3-POINT TYPE WITH RETRACTOR

Every person who drives or rides in this vehicle should wear a seat belt at all times.

Fastening the belts

1. Adjust the seat.

The seatback should not be reclined any more than needed for comfort. Seat belts are most effective when the passenger sits well back and straight up in the seat. If the seat is reclined, the risk of sliding under the lap belt and being injured is increased.

2. Slowly pull the seat belt out of the retractor and insert the tongue into the buckle until it snaps.

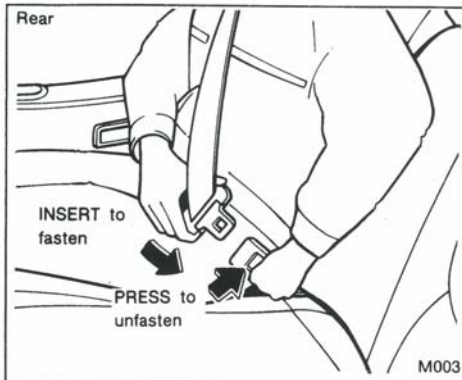

The retractor is designed to lock during a sudden stop or on impact. A slow pulling motion will permit the belt to move, and allow you some freedom of movement in the seat.

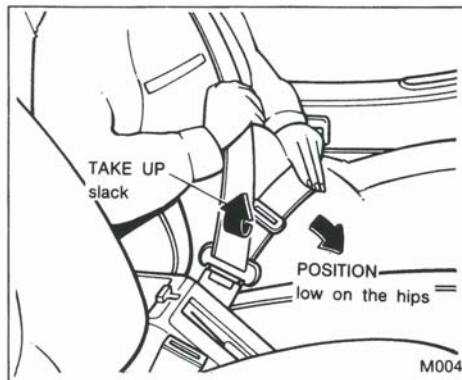

3. Position the lap belt portion **low on the hips** as shown.
4. Pull the shoulder belt portion toward the retractor to take up extra slack.

Unfastening the belts

To unfasten the belt, press the button on the buckle. The seat belt will automatically retract.

Checking seat belt operation (3-point type with retractor)

Your seat belt retractors are designed to lock belt movement by two separate methods:

- 1) When the belt is pulled quickly from the retractor.
- 2) When the vehicle slows down rapidly.

To increase your confidence in the belts, check the operation as follows:

- Grasp the shoulder belt and pull quickly forward. The retractor should lock and restrict further belt movement.

If the retractor does not lock during this check or if you have any question about belt operation, see your NISSAN dealer.

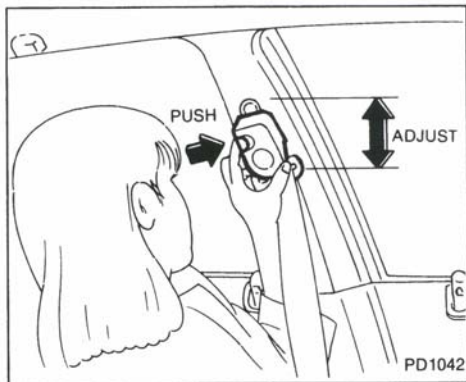

Shoulder belt height adjustment (For front seats of Canada models)

The shoulder belt anchor height should be adjusted to the position best for you. To adjust, push the release button, then move it to the desired position, so that the belt passes over the shoulder.

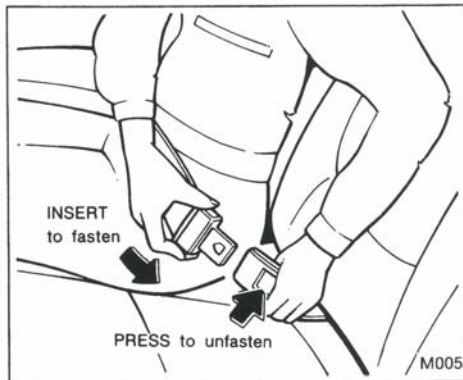

2-POINT TYPE WITHOUT RETRAC- TOR

Fastening the belts

1. Insert the tongue into the buckle until it snaps.

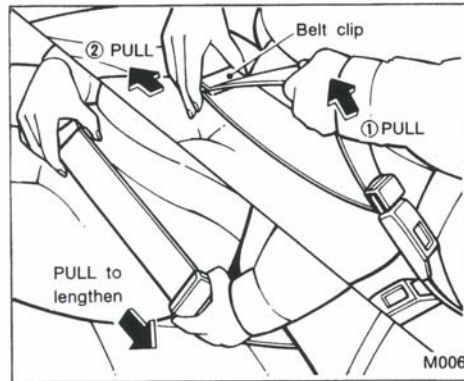

2. To lengthen, hold the tongue at a right angle to the belt and pull on the belt. To shorten, pull the free end of the belt away from the tongue, then pull the belt clip to take up the slack.

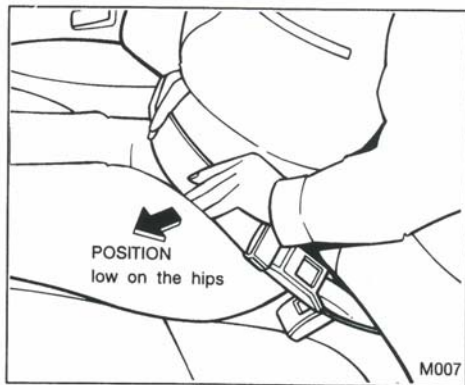

3. Position the lap belt **low on the hips** as illustrated.

Unfastening the belts

To unfasten the belt, press the button on the buckle.

Fasten the seat belts when not in use to prevent them from being caught in the door.

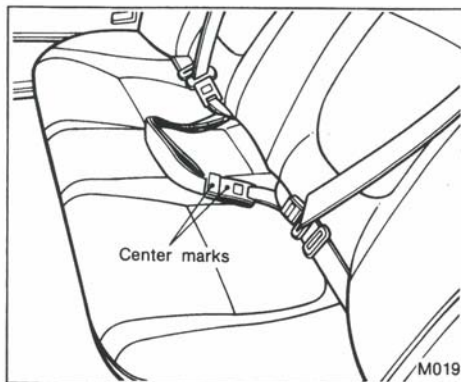

Selecting correct set of belts

The center seat belt buckle and tongue are identified by the "CENTER" label. The center seat belt tongue can be fastened **only** into the center seat belt buckle.

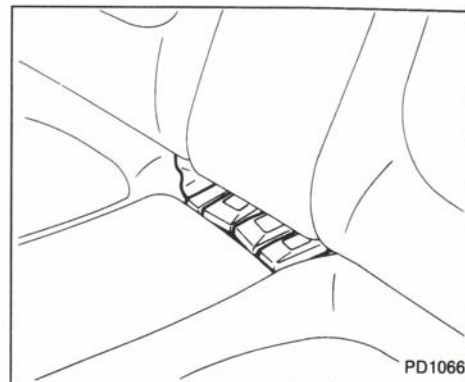

Rear seat belt buckles

Rear seat belt buckles can be stored, if there are no people riding in the rear seat.

SEAT BELT EXTENDERS (Except for the automatic seat belt)

If, because of body size or driving position, it is not possible to properly fit the lap-shoulder belt and fasten it, an extender is available which is compatible with the installed seat belts. The extender adds approximately 8 inches (200 mm) of length and may be used for either the driver or front passenger seating position. See your NISSAN dealer for assistance if the extender is required.

WARNING:

- Only NISSAN belt extenders, made by the same company which made the original equipment belts, should be used with NISSAN belts.
- Persons who can use the standard seat belt should not use an extender. Such unnecessary use could result in serious personal injury in the event of an accident.

SEAT BELT MAINTENANCE

- To clean the belt webbings, apply a mild soap solution or any solution recom-

mended for cleaning upholstery or carpets. Then brush it, wipe with a cloth and allow it to dry in the shade. Do not allow the belts to retract until they are completely dry.

- Periodically check to see that the belt and the metal components such as buckles, tongues, retractors, flexible wires and anchors work properly. If loose parts, deterioration, cuts or other damage on the webbing is found, the entire belt assembly should be replaced.

CHILD RESTRAINT SYSTEMS FOR INFANTS AND SMALL CHILDREN

Infants and small children should always be placed in an infant or child restraint system while riding in the vehicle.

WARNING:

Children and infants should never be carried on your lap. It is not possible for even the strongest adult to resist the forces of an accident. The child could be crushed between the adult and parts of the vehicle. Also, do not put the same seat belt around both your child and yourself.

In general, child restraint systems are de-

signed to be installed with a lap belt or the lap portion of a three-point type seat belt. A child restraint system should never be installed with an automatic belt (also known as a "passive" belt), since such a belt will not properly secure the child seat.

For Automatic Seat Belt System, a specially designed supplementary genuine NISSAN child restraint buckle is required to properly secure the child seat. Refer to page 2-25.

Nissan recommends that the child restraint system be installed in the rear seat, unless the child is an infant and you are the only adult in the car. According to accident statistics, children are safer when properly restrained in the rear seat than in the front seat.

An improperly installed child restraint could lead to serious injury in an accident.

Child restraint systems specially designed for infants and small children are offered by several manufacturers. Some systems may be used for both infants and small children. When selecting any child restraint system, keep the following points in mind:

- 1) Choose only a system with a label certi-

fyng that it complies with Federal Motor Vehicle Safety Standard 213 or Canadian Motor Vehicle Safety Standard 213.

- 2) Place your child in the child restraint and check the various adjustments to be sure the child restraint is compatible with your child. Always follow all recommended procedures.
- 3) Check the child restraint in your vehicle to be sure it is compatible with the vehicle's seat belt system.

WARNING:

- Follow all of the child restraint manufacturer's instructions for installation and use. When purchasing a child restraint, be sure to select one which will fit your child and vehicle as it may not be possible to properly install some types of child restraints in your vehicle.

Improper use of a child restraint system can result in increased injuries for both the infant or child and other occupants in the vehicle.

- When your child restraint system is not in use, store it in the trunk or keep it secured with a seat belt to prevent it

from being thrown forward in case of a sudden stop or accident.

- Remember that a child restraint left in a closed vehicle can become very hot. Check the seating surface and buckles before placing your child in the child restraint.
- All U.S. states and some provinces or territories require that infants and small children be restrained in approved child restraint systems at all times while the vehicle is being operated.

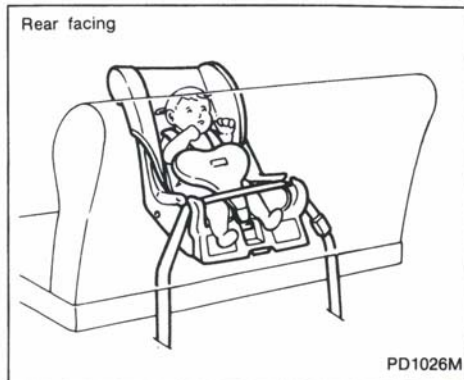

Installation on rear seat

Center lap belt

Secure the child restraint with the lap belt as illustrated. Remove all slack in the lap belt for a very tight fit by pulling forcefully on the lap belt adjustment.

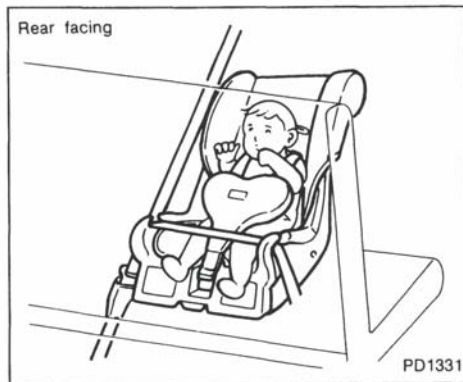
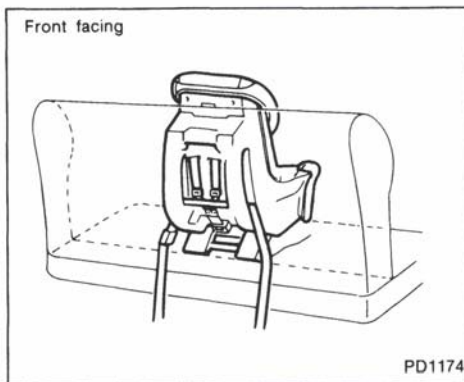

Rear outboard shoulder/lap belt

Installing the child restraint using the emergency locking retractor

1. Place the child restraint on the rear outboard seat. Anchor down the top strap if provided with your child restraint.
2. Pull the lap belt as far as possible out of the retractor. The lap belt will hold automatically without winding back into the retractor.

3. Secure the child restraint with the lap belt as instructed by the manufacturer.
4. Lightly tug on the belt and let it wind back into the retractor until there is no slack. Lightly tug on it until it locks.

Front facing



PD1332

5. Try to move the child restraint in several directions to make sure that it is secure and safe.
6. Secure the child in the child restraint as instructed by the manufacturer.

After the child restraint is removed and the seat belt is allowed to wind back into the retractor, the emergency locking retractor may be used as normal and will only lock during a sudden stop or impact.

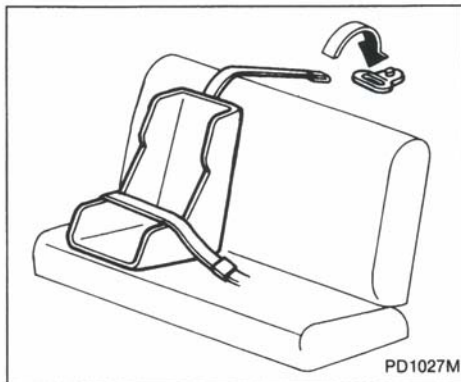

PD1027M

If your child restraint has a top strap, install the anchor bracket to the provided anchor point. Secure the child restraint with the outboard lap belt and latch the top strap hook onto the anchor bracket. To install the anchor bracket, a metric bolt of the dimensions listed below must be used.

Bolt diameter: 8.0 mm
Bolt length: more than 1.18 in (30 mm)
Thread pitch: 1.25 mm

Child restraint anchor points are designed to withstand only those loads imposed by correctly fitted child restraints. Under no circumstances are they to be used for adult seat belts or harnesses.

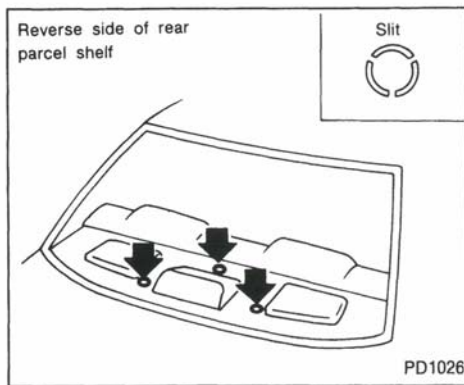

Anchor point locations

Anchor points are located under the rear parcel shelf finisher. Cut along the slit circles of the rear parcel shelf finisher with a knife.

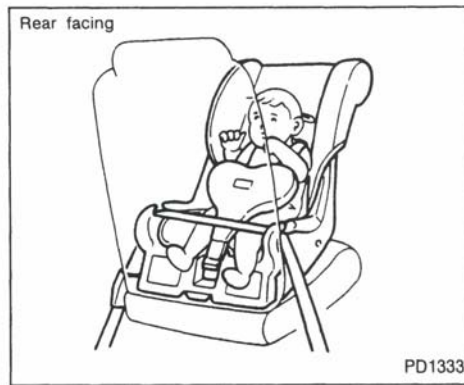

Installation on front passenger seat (For U.S.A.- Automatic seat belt)

Never install the child restraint with the automatic shoulder belt. It is not suitable to secure the child restraint.

Installing the child restraint using the emergency locking retractor

1. Place the child restraint on the passenger seat. Anchor down the top strap if provided with your child restraint.

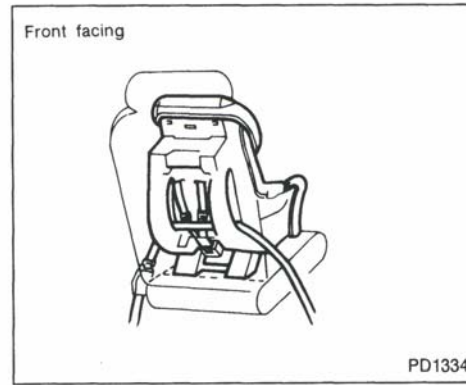

2. Pull the lap belt as far as possible out of the retractor. The lap belt will hold automatically without winding back into the retractor.
3. Secure the child restraint with the lap belt as instructed by the manufacturer.
4. Lightly tug on the belt and let it wind back into the retractor until there is no slack. Lightly tug on it until it locks.
5. Try to move the child restraint in several directions to make sure that it is secure and safe.

6. Secure the child in the child restraint as instructed by the manufacturer.

After the child restraint is removed and the seat belt is allowed to wind back into the retractor, the emergency locking retractor may be used as normal and will only lock during a sudden stop or impact.



Installation on front passenger seat (For Canada — 3-point type with retractor)

Installing the child restraint using the emergency locking retractor

1. Place the child restraint on the passenger seat. Anchor down the top strap if provided with your child restraint.
2. Pull the lap belt as far as possible out of the retractor. The lap belt will hold automatically without winding back into the retractor.

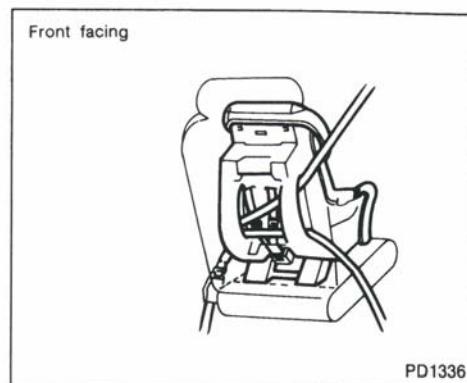

3. Secure the child restraint with the lap belt as instructed by the manufacturer.
4. Lightly tug on the belt and let it wind back into the retractor until there is no slack. Lightly tug on it until it locks.
5. Try to move the child restraint in several directions to make sure that it is secure and safe.
6. Secure the child in the child restraint as instructed by the manufacturer.

TILTING STEERING WHEEL

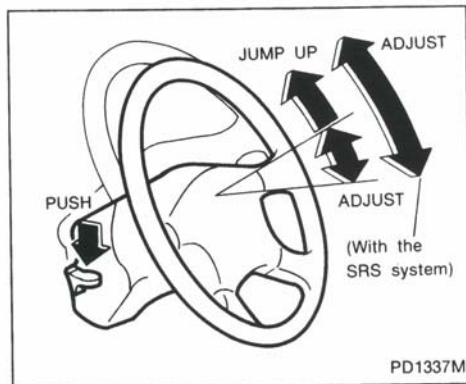

After the child restraint is removed and the seat belt is allowed to wind back into the retractor, the emergency locking retractor may be used as normal and will only lock during a sudden stop or impact.

Tilt operation

Push the lock lever and while holding it, adjust the steering wheel up or down to the desired position.

Jump up operation

Just push the lock lever and the steering wheel will automatically jump up. This lets the driver get into and out of the seat easily.

After sitting in the seat, push the lock lever down again and pull the steering wheel down.

NOTE:

Due to the design of the optional Air Bag Supplemental Restraint System. Maxima models with the SRS system do not include the "Jump Up" feature.

WARNING:

Do not adjust the steering wheel while driving.

OUTSIDE MIRRORS

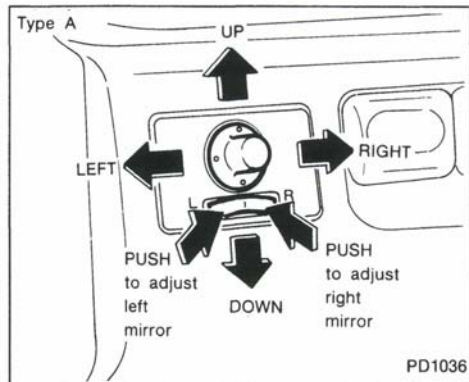

Push the right or left end of the switch to select the right or left side mirror, then adjust using the control lever.

Objects viewed in the outside mirror on the passenger side are closer than they appear.

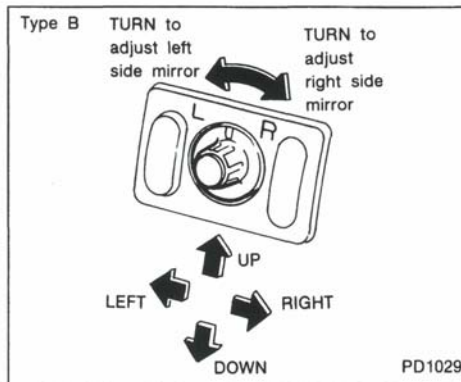

Turn the knob to right or left to select the right or left side mirror, then adjust using the knob.

Objects viewed in the outside mirror on the passenger side are closer than they appear.

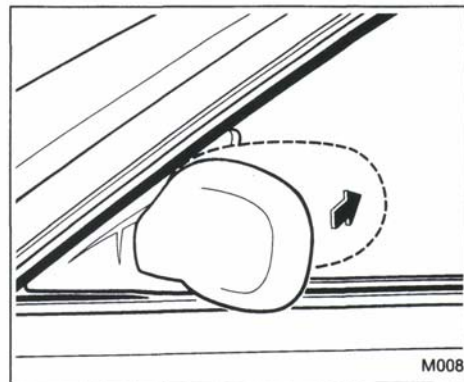

Push the outside mirror backward to fold it.

INSIDE MIRROR

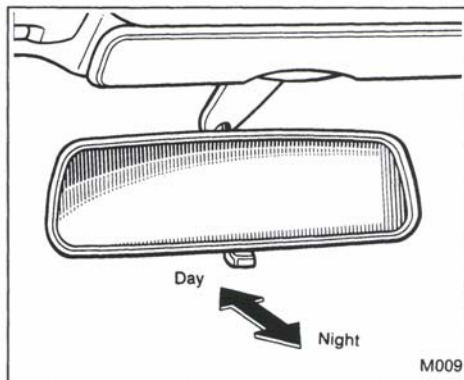

The night position will reduce glare from the headlights of vehicles behind you at night.

CAUTION:

Use the night position only when necessary, because it reduces rear view clarity.

MEMO

MEMO

MEMO

3 Heater, air conditioner and audio system

[Heater and air conditioner]

Ventilator	3-2
Foot vent.....	3-2
Heater and air conditioner	3-3
Automatic air conditioner	3-10

[Audio]

Radio.....	3-13
CB radio or car phone	3-31



VENTILATOR

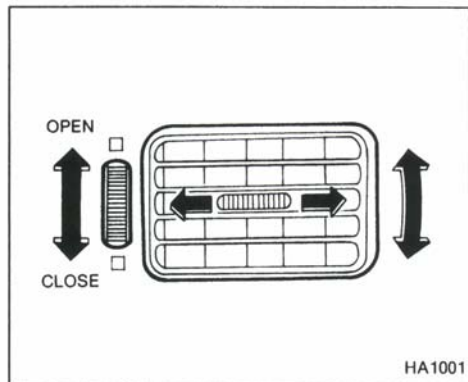

Open or close, and adjust the air flow direction of ventilators.

FOOT VENT

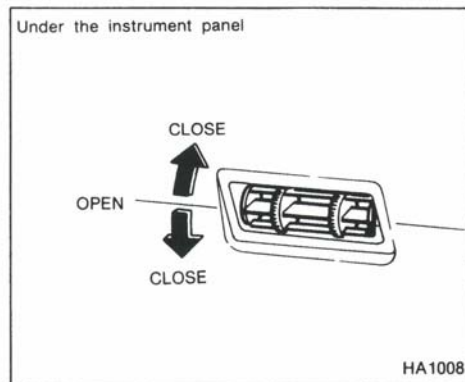

Open or close the foot ventilator.

HEATER AND AIR CONDITIONER

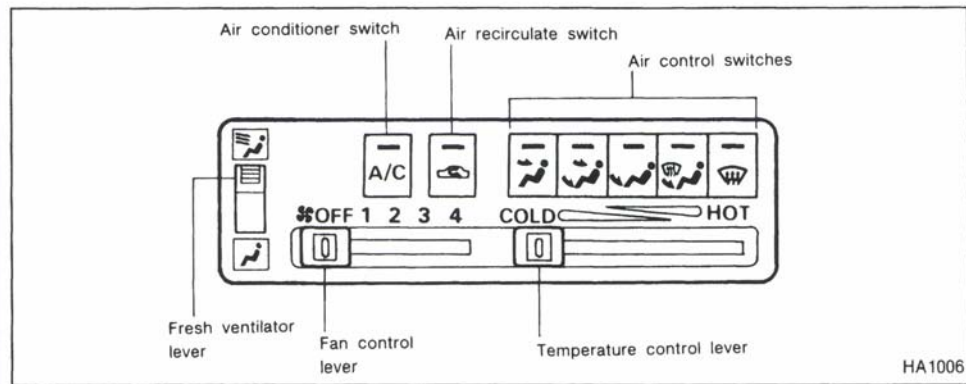

CONTROLS

Fan control lever

This lever turns the fan on and off, and controls fan speed.

Air control switches

These switches allow you to select the outlet air flow.

Temperature control lever

This lever allows you to adjust the temperature of the outlet air.

Air recirculate switch

OFF position (The indicator light turns off.)

Outside air is drawn into the passenger compartment when this switch is off.

Use this position for normal heater or air conditioner operation.

ON position (The indicator light turns on.)

Interior air is recirculated inside the vehicle.

Push the switch to the "ON" position when driving on a dusty road and for maximum cooling when using the air conditioner.

WARNING:

Do not use in this position for long periods of time because it may cause the interior air to become stuffy and the windows to fog up.

Air conditioner switch (If so equipped)

Start the engine, move the fan control lever to the desired (1 to 4) position and push the air conditioner button to turn on the air conditioner. The indicator light will come on when the air conditioner is on. To stop the air conditioner, push the switch again to return it to the original position.

The air conditioner cooling function operates only when the engine is running.



Fresh air ventilation lever

This lever affects the temperature of the air coming out of the FACE VENTS only. It functions independently of the RECIRC lever and the A/C switch.

With the vent lever in the "  " position, the ventilation system operates normally. Incoming air from the face vents passes through the A/C system (to be dehumidified and cooled), then through the heater system (to adjust the temperature), then through the face vents. When the temperature lever is set to a heating position, the air at the face vents may be too warm.

With the vent lever in the "  " position,

air coming out of the face vents does not pass through the heater system. This allows cool air to flow from the face vents and heated air to flow from the foot vents and defroster.

Use the "  " position only when you desire unheated air from the face vents. The lever should normally be kept in the "  " position.

HEATER OPERATION

Heating

This mode is used to direct the main flow of hot air to the floor outlets.

1. Push the air recirculate switch OFF for normal heating.
 2. Push the "  " button in.
 3. Turn on the fan control lever.
 4. Move the temperature control lever to the desired position between the middle and the "HOT" position.
- For quick heating, push the air recirculate switch ON. Be sure to turn off the air recirculate switch for normal heating.

Ventilation

This mode directs outside air from the side, and center vents.

1. Push the air recirculate switch OFF.
2. Push the "  " switch in.
3. Turn on the fan control lever.
4. Move the temperature control lever to the desired position.

Defrosting or defogging

This mode is used to defrost/defog the windows.

1. Push the " " switch in.
2. Turn on the fan control lever.
3. Move the temperature control lever to the desired position between the middle and the "HOT" position.

- To quickly remove ice or fog from the windows, move the fan control lever to "4" and the temperature control lever to the full "HOT" position.
- When the " " switch is pushed, the air conditioner will automatically be turned on to defog the windshield, and the air recirculate mode will automatically be turned off.

Outside air is drawn into the passenger compartment to improve the defogging performance.

Bi-level heating

This mode directs outside air from the side and center vents and hot air from the floor outlets.

1. Push the air recirculate switch OFF.
2. Push the " " switch in.
3. Turn on the fan control lever.
4. Normally move the temperature control lever to the midpoint between "HOT" and "COLD".

Heating and defogging

This mode heats the interior and defogs the windshield.

1. Push the " " switch in.
2. Turn on the fan control lever.
3. Move the temperature control lever to the desired position between the middle and the "HOT" position.

Operating tips

- **Clear snow and ice from the wiper blade and air inlet in front of the windshield. This will improve heater operation.**
- When the " " switch is pushed, the air recirculate mode will automatically be turned off.

Outside air is drawn into the passenger

compartment to improve the defogging performance.

AIR CONDITIONER OPERATION

Start the engine, move the fan control lever to the desired (1 to 4) position and push in the air conditioner button to activate the air conditioner. When the air conditioner is on, cooling and dehumidifying functions will be added to the heater operation.

The air conditioner cooling function operates only when the engine is running.

Cooling

This mode is used to cool and dehumidify.

1. Push the air recirculate switch OFF.
 2. Push the " " switch in.
 3. Turn on the fan control lever.
 4. Push on the air conditioner button. The indicator light will come on.
 5. Move the temperature control lever to the desired position.
- For quick cooling when the outside temperature is high, push the air recirculate switch ON. Be sure to push the air recirculate switch OFF for normal cooling.



Dehumidified heating

This mode is used to heat and dehumidify.

1. Push the air recirculate switch OFF.
2. Push the " " switch in.
3. Turn on the fan control lever.
4. Push on the air conditioner button. The indicator light will come on.
5. Move the temperature control lever to the desired position.

Dehumidified defogging

This mode is used to defog the windows and dehumidify.

1. Push the " " switch in.
 2. Turn on the fan control lever.
 3. Move the temperature control lever to the desired position.
- When the " " switch is pushed, the air conditioner will automatically be turned on to defog the windshield, and the air recirculate mode will automatically be turned off.

Outside air is drawn into the passenger

compartment to improve the defogging performance.

Operating tips

- Keep windows and sun roof closed while the air conditioner is in operation.
- After parking in the sun, drive for two or three minutes with the windows open to vent hot air from the passenger compartment. Then, close the windows. This will allow the air conditioner to cool the interior more quickly.
- The air conditioning system should be operated for about ten minutes at least once a month. This helps prevent damage to the system due to lack of lubrication.
- If the coolant temperature gauge exceeds the HOT position, turn the air conditioner off. See "If your vehicle overheats" in the "In case of emergency" section for additional information.

AIR FLOW CHART

The chart below shows the switch and lever positions for **MAXIMUM and QUICK** heating, cooling or defrosting.

The air recirculation switch should be in the "OFF" position for normal cooling, heating and defrosting.

DEFROSTING DEFOGGING

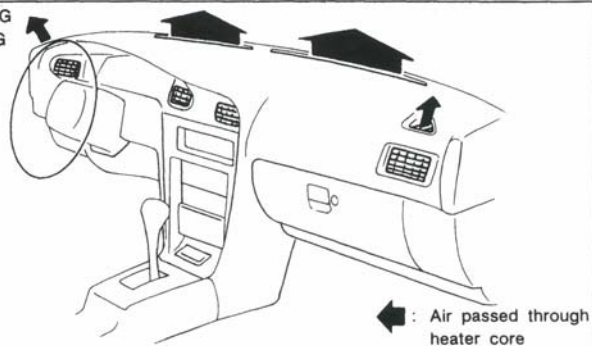

Air conditioner switch Air recirculate switch Air control switches



Fresh ventilator lever Fan control lever Temperature lever

A/C switch if so equipped	Air recirculation	Air control	Temp control	Fresh ventilator lever
ON	OFF	DEF	HOT (RIGHT)	 DOWN

HA1118

HEATING

Heated air at
center vents

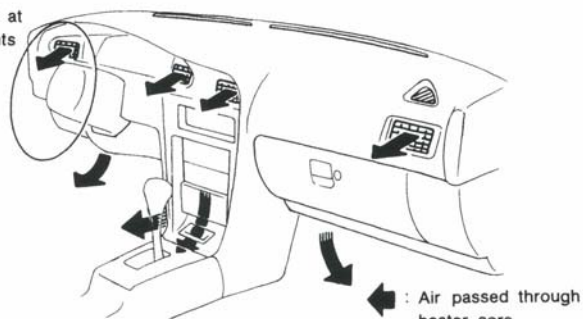

Air conditioner switch Air recirculate switch Air control switches

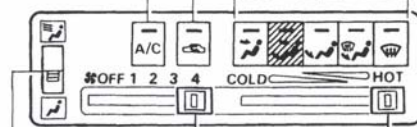

Fresh ventilator lever Fan control lever Temperature lever

A/C switch if so equipped	Air recirculation	Air control	Temp control	Fresh ventilator lever
OFF	ON	FOOT & FACE	HOT (RIGHT)	 DOWN

HA1119

HEATING

Cool air at center vents

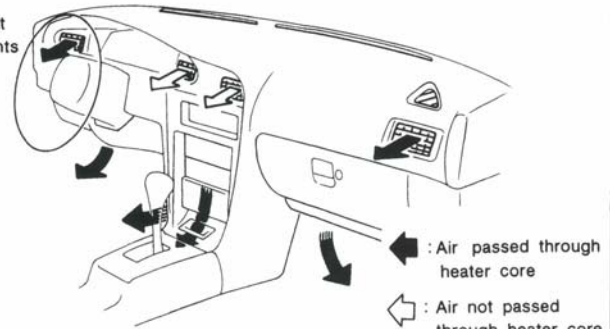

• Air conditioner switch Air recirculate switch Air control switches

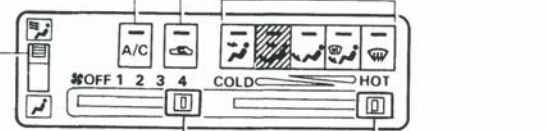

Fresh ventilator lever Fan control lever Temperature control lever

A/C switch If so equipped	Air recirculation	Air control	Temp control	Fresh ventilator lever
OFF	OFF	FOOT & FACE	HOT (RIGHT)	UP

HA1120

HEATING

No air at center vents

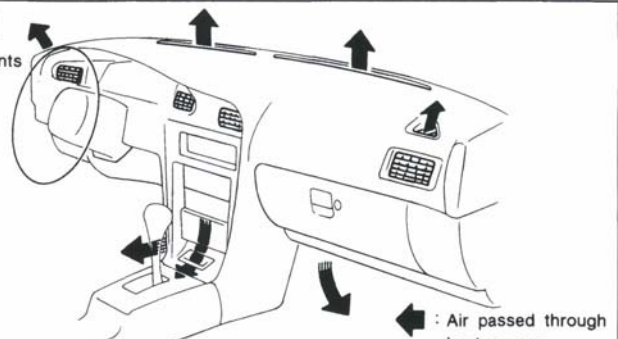

Air conditioner switch Air recirculate switch Air control switches

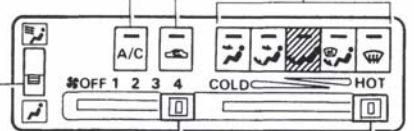

Fresh ventilator lever Fan control lever Temperature lever

A/C switch If so equipped	Air recirculation	Air control	Temp control	Fresh ventilator lever
OFF	ON	FOOT	HOT (RIGHT)	DOWN

HA1121

COOLING

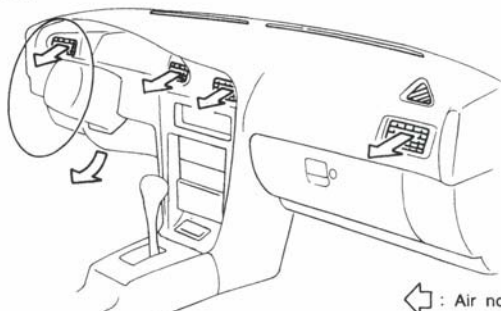

← : Air not passed through heater core

Air conditioner switch

Air recirculate switch

Air control switches

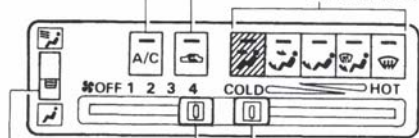

Fresh ventilator lever

Fan control lever

Temperature lever

A/C switch If so equipped	Air recirculation	Air control	Temp control	Fresh ventilator lever
ON	ON	FACE	COLD	 DOWN

HA1122

AUTOMATIC AIR CONDITIONER

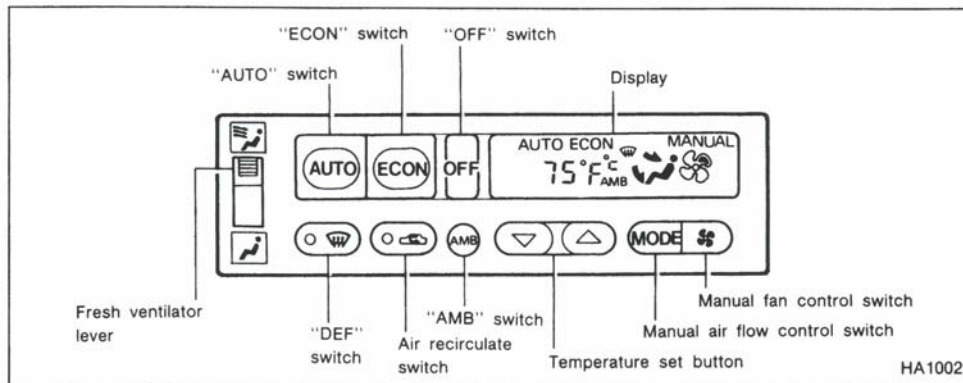



Start the engine and operate the controls to activate the air conditioner.

The air conditioner cooling function operates only when the engine is running.



Cooling and/or dehumidified heating (Auto mode)

This mode may be normally used all year round as the system automatically works to keep a constant temperature. Air flow distribution and fan speed are also controlled automatically.

1. Push the AUTO switch on. ("AUTO" will be displayed.)
 2. Push the temperature set button   to set the desired temperature.
- Adjust the temperature set button to about 75°F (24°C) for normal operation.
 - The temperature of the passenger compartment will be maintained automatically. Air flow distribution and fan speed are also controlled automatically.

Heating (ECON mode)

The air conditioning does not activate. When you need to heat only, use this mode.

1. Push the ECON (ECONOMY) switch on. ("ECON" will be displayed.)
 2. Push the temperature set button   to set the desired temperature.
- The temperature of the passenger compartment will be maintained automatically. Air flow distribution and fan speed are also controlled automatically.
 - Do not set the temperature lower than the outside air temperature. Otherwise the system may not work properly.
 - Not recommended if windows fog up.



Fresh air ventilation lever

This lever affects the temperature of the air coming out of the FACE VENTS only. It functions independently of the RECIRC lever and the A/C switch.





With the vent lever in the "  " position, the ventilation system operates normally. Incoming air from the face vents passes through the A/C system (to be dehumidified and cooled), then through the heater sys-

tem (to adjust the temperature), then through the face vents. When the temperature lever is set to a heating position, the air at the face vents may be too warm.

With the vent lever in the "  " position, air coming out of the face vents does not pass through the heater system. This allows cool air to flow from the face vents and heated air to flow from the foot vents and defroster.

Use the "  " position only when you desire unheated air from the face vents. The lever should normally be kept in the "  " position.

Dehumidified defogging

1. Push the DEF  switch on. (The indicator light on the switch will come on.)
 2. Push the temperature set button   to set the desired temperature.
- To quickly remove ice or fog from the outside of the windows, push the manual fan control switch  and set to the maximum position .
 - As soon as possible after the windshield is clean, push the AUTO switch to return to the auto mode.

- When the DEF  switch is pushed, the air conditioner will automatically be turned on at outside temperatures above 35°F (2°C) to defog the windshield, and the air recirculate mode will automatically be turned off.

Outside air is drawn into the passenger compartment to improve the defogging performance.

Manual fan speed control

Push the fan control switch  to manually control the fan speed.

- Push the AUTO switch to return to automatic control of the fan speed.

Air recirculate switch

Push the air recirculate switch  to recirculate interior air inside the vehicle. The indicator light on the switch will come on.

Push it again to draw outside air into the passenger compartment. The indicator will go out.

- The air recirculate switch will not be activated when the air conditioner is in DEF mode.

Manual air flow control switch "MODE"

Pushing the manual air flow control switch selects the air outlet to:

 : Air flows from center and side ventilators.

 : Air flows from center and side ventilators and foot outlets.

 : Air flows mainly from foot outlets.

To turn system off

Push the OFF switch.

Ambient temperature switch "AMB"

Push the ambient temperature switch. The outside ambient temperature will be displayed for approximately five seconds.

Operating tips

- When the engine coolant temperature and outside air temperature are low, the air flow from the foot outlets may not operate for a maximum of 150 seconds. However, this is not a malfunction. After the coolant temperature warms up, the

air flow from the foot outlets will operate normally.

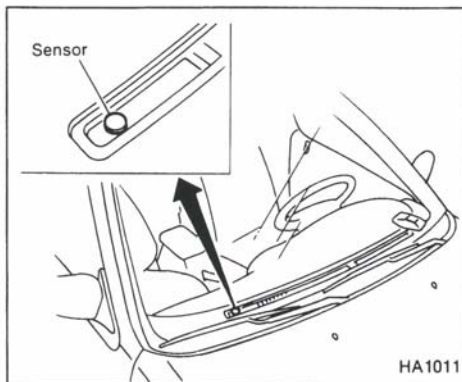

The sensor on the instrument panel helps maintain a constant temperature; do not put anything on or around this sensor.

Servicing air conditioner

The air conditioning system in your NISSAN vehicle is charged with a new refrigerant designed with the environment in mind. **This new refrigerant will not harm the earth's ozone layer.** However it may contribute in a small part to global warming. Special charging equipment and lubricant are required when servicing your NISSAN air conditioner. Using improper refrigerants or lubricants will cause severe damage to your air conditioning system. See AIR CONDITIONING SYSTEM REFRIGERANT AND LUBRICANT RECOMMENDATIONS in the TECHNICAL AND CONSUMER INFORMATION section of this manual.

Your NISSAN dealer will be able to service your environmentally "friendly" air conditioning system.

RADIO

To turn the radio on, turn the ignition key to "ACC" or "ON". If you listen to the radio with the engine not running, turn the key to the "ACC" position.

Radio reception is affected by station signal strength, distance from radio transmitter, buildings, bridges, mountains and other external influences. Intermittent changes in reception quality normally are caused by these external influences.

AM-FM RADIO WITH CASSETTE PLAYER (Bose audio system)

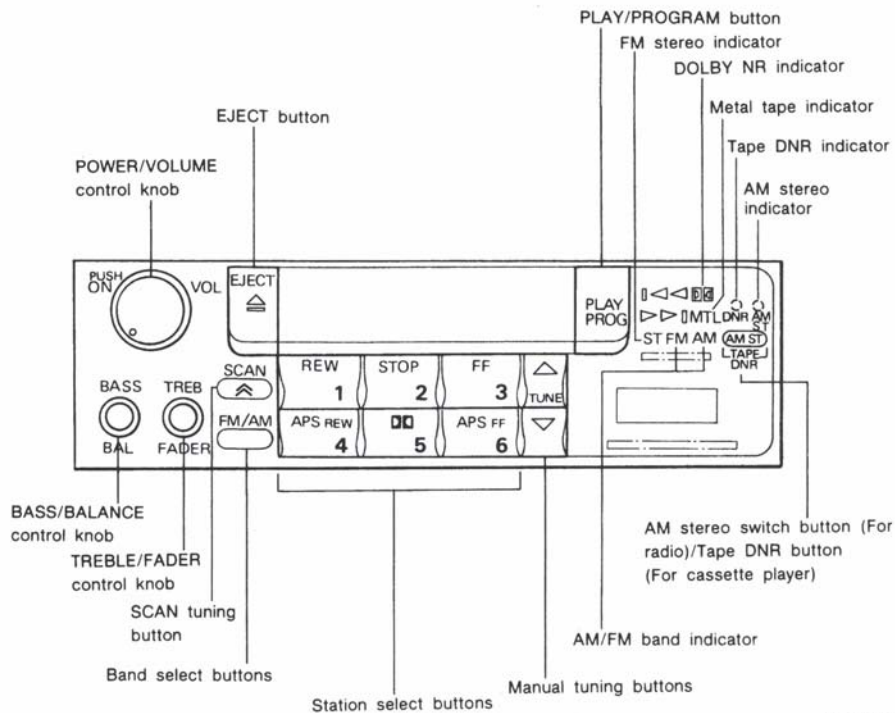

HA1078M

AM-FM RADIO WITH CASSETTE PLAYER (Bose audio system)

Head unit

The electronic tuning radio has an FM Diversity reception system. The FM Diversity system employs two antennas: one is a rod type antenna and the other is an antenna printed on the window.

This system automatically switches to the antenna which is receiving less noise. The noise is further reduced through the use of the Dynamic Noise Reduction (DNR) system, which adds to the high quality reception.

The tape deck employs an amorphous head which allows for improved reproduction of high frequency ranges. Noise is also greatly reduced by the combined use of the Dolby noise reduction system. The auto loudness circuit enhances the low frequency range automatically in both radio reception and tape playback.

Bose speaker

A large output amplifier featuring a low distortion ratio is connected directly to each speaker unit and provides increased output

and excellent tonal quality. The equalizing circuit and reverberating speaker box permit regeneration of forcible base sound. This equalizing circuit permits the sound efficiency to be matched with the interior conditions of the Maxima for a selection between "natural sound" and "high-fidelity sound."

Radio operation

Push the SW.VOL knob to listen to the radio and tune in the desired station.

Pushing the SW.VOL knob while the cassette tape is playing will turn off the cassette player and turn on the radio.

Turn the SW.VOL knob to adjust the volume.

Selecting the desired band

Push the band select button to change from AM to FM reception.



The FM stereo indicator "ST" will glow during FM stereo reception. When the stereo broadcast signal is weak, the radio will automatically change from stereo to monaural reception.

Push the AM stereo button for AM stereo

reception. The AM stereo indicator will come on.

Tuning

Manual tuning

Push either manual tuning button  , or  .

SCAN tuning

Push the SCAN tuning button  . SCAN tuning begins from low to high frequencies and stops at each broadcasting station for five seconds. Pushing the button again during this five second period will stop SCAN tuning and the radio will remain tuned to that station.

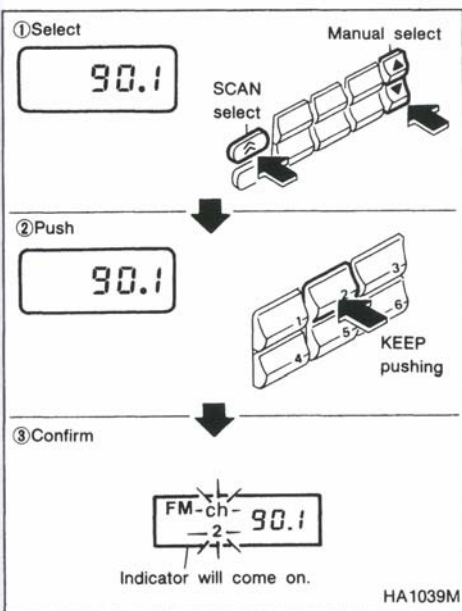

than 2 seconds. (For example in the diagram ch2 is to be memorized. The radio ceases emitting sounds when the select button is pushed.)

- The indicator, "ch2" will then come on and the sound will resume. Memorizing is now complete.
- Other buttons can be set in the same manner.

If the battery cable is disconnected, or if the fuse blows, the radio memory will be cancelled. In that case, reset the desired stations.

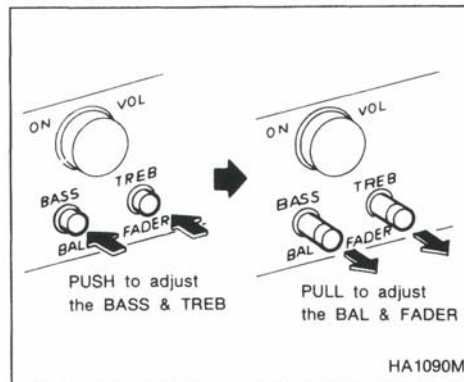

Adjusting tone quality

Push then turn the BASS and TREB (TREBLE) control knobs to obtain the most pleasant sound.

Adjusting speaker sound balance

Pull then turn the BALANCE (BAL) control knob to adjust the volume between the right and left speakers.

Station memory operations

Six stations can be set for each band.

- Tune to the desired station.
- Push the desired select button for more

FADER volume control

Pull then turn the FADER control knob to adjust the volume between the front and rear speakers.

DNR (Dynamic Noise Reduction)

DNR is automatically operated when the radio is turned on. It reduces high frequency background hiss.

DNR™ is a trade mark of National semiconductor corporation.

Cassette tape operation

Turn the ignition key to "ACC" or "ON", then lightly insert the cassette tape into the tape door.

The cassette tape will be automatically pulled into the player.

The radio will turn off and the cassette tape will begin to play.

Do not force the cassette tape into the tape door.

Pressing strongly could cause player damage.

The cassette tape will automatically change directions to play the other side when the

first side is completed.

PLAY button

You may push the PLAY button when:

- the tape has stopped playing,
- the tape has been fast forwarded,
- the tape has been rewind,
- the radio is on.

Fast forwarding or rewinding the tape

Push either the FF (forward) or REW (rewind) button for the desired direction.

The indicator light on the switch will come on.

Push either the APS FF or APS REW button while the cassette tape is playing. The tape will run quickly, and stop and play at the next program. The indicator light flashes "ON" and "OFF" while searching the program.

This system searches at the blank intervals between selections. If there is a blank interval within one program or there is no interval between programs, the system may not search correctly.

Changing the direction of tape play

Push the PROG (program) select button.

Dolby NR (noise reduction)

Push the  "DOLBY NR" button for DOLBY NR encoded tapes to reduce high frequency tape noise. The indicator will glow on the button.

Dolby NR is manufactured under license from Dolby Laboratories Licensing Corporation. "Dolby NR" and the double-D symbol are trademarks of Dolby Laboratories Licensing Corporation.

DNR (Dynamic Noise Reduction)

Push the "DNR" button to reduce high frequency background hiss. (The indicator will glow on the display.) It works on all kinds of tapes, so there is no need for encoded tapes.

NISSAN recommends that the "DNR" button be pushed while the cassette tape is playing.

DNR™ is a trademark of National semiconductor corporation.

Metal or chrome tape usage

The cassette player will be automatically set to high performance play when playing a metal or chrome cassette tape.

The indicator will come on when playing a metal or chrome cassette tape.

Stopping and ejecting the cassette tape

Push the eject button.

Precautions on cassette player operation

- **To maintain good quality sound, NISSAN recommends that you use cassette tapes of 60 minutes or shorter in length.**
- **Cassette tapes should be removed from the player when not in use. Store cassettes in their protective cases and away from direct sunlight, heat, moisture and magnetic sources.**

Direct sunlight can cause the cassette to become deformed. The use of deformed cassettes may cause the cassette to jam in the player.

- **Do not use cassettes that have labels**

which are peeling and loose. If used, the label could jam in the player.

- **If a cassette has loose tape, insert a pencil through one of the cassette hubs and rewind the tape firmly around the hubs. Loose tape may cause tape jamming and wavering sound quality.**
- **Over a period of time, the playback head, capstan and pinch roller may gather a tape coating residue as the tape passes over the head. This residue accumulation can cause a weak or wavering sound and should be removed periodically with a head cleaning tape. If the residue is not removed periodically, the player may need to be disassembled for cleaning.**

AM/FM ELECTRONIC TUNING RADIO WITH CASSETTE PLAYER (Active speaker system)

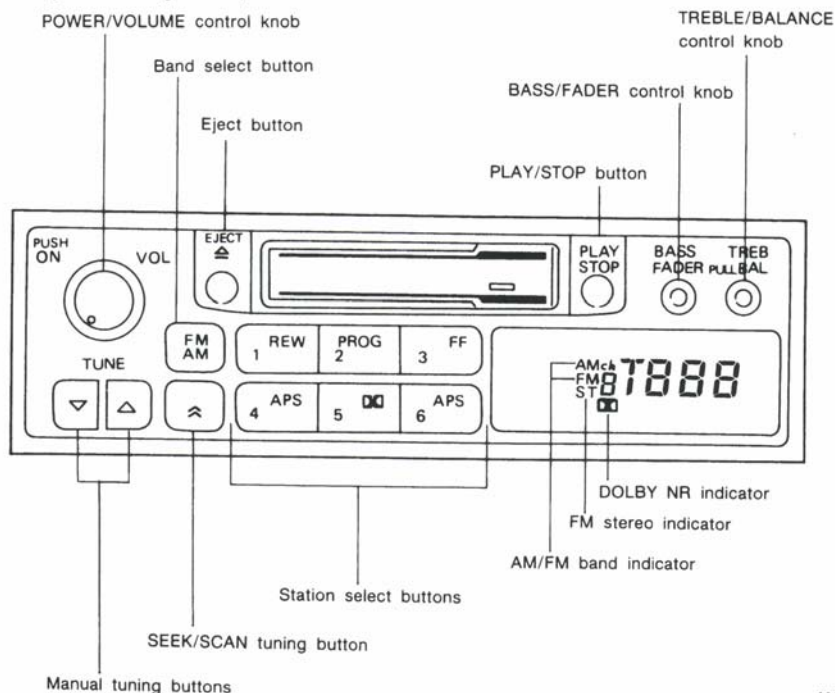

HA1086

AM-FM RADIO WITH CASSETTE PLAYER (ACTIVE SPEAKER sys- tem)

The ACTIVE SPEAKER system creates clear sound ranging from small volume to large volume. The equalizing circuit compensates for disturbances in the medium and high frequency ranges based on the acoustics of the room. The auto loudness circuit eliminates insufficient power in the low frequency range when the volume is low.

The vehicle's environment has been tuned to suit the sound efficiency peculiar to the Maxima.

This permits music to be enjoyed clearly not only in the driver's seat but also in any seat in the vehicle.

Radio operation

Push the ON.VOL knob to listen to the radio and tune in the desired station.

Pushing the ON.VOL knob while the cassette tape is playing will turn off the cassette player and turn on the radio.

Turn the ON.VOL knob to adjust the volume.

The electronic tuning radio has an FM DIVERSITY reception system. The FM DIVERSITY system employs two antennas; one is a rod type antenna and the other is an antenna printed on the front window. This system automatically switches to the antenna which receives less noise. Thus the radio provides high quality reception.



Selecting the desired band

Push the band select button to change from AM to FM reception.

The FM stereo indicator "ST" will glow during FM stereo reception. When the stereo broadcast signal is weak, the radio will automatically change from stereo to monaural reception.

Tuning

Manual tuning

Push either manual tuning button  , or  .

SCAN tuning

Push the SEEK/SCAN tuning button  for more than 1.5 seconds. SCAN tuning begins from low to high frequencies and stops at each broadcasting station for

five seconds. Pushing the button again during this five second period will stop SCAN tuning and the radio will remain tuned to that station.

SEEK tuning

Push the SEEK/SCAN tuning button  for less than 1.5 seconds. SEEK tuning begins from low to high frequencies and stops at the next broadcasting station.

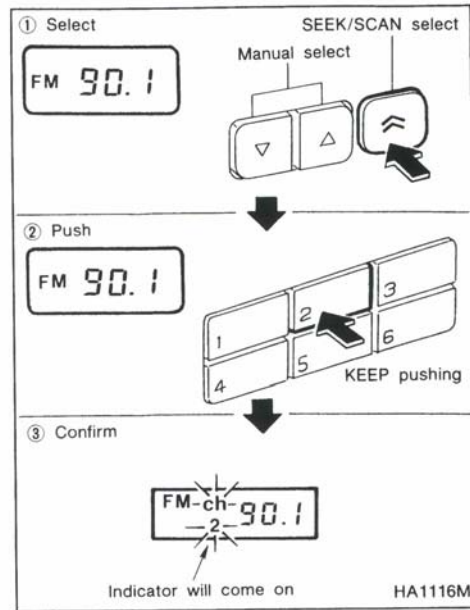

Station memory operations

Six stations can be set for each band.

1. Tune to the desired station.
2. Push the desired select button for more

than 2 seconds. (For example in the diagram ch2 is to be memorized. The radio ceases emitting sounds when the select button is pushed.)

3. The indicator, "ch2" will then come on and the sound will resume. Memorizing is now complete.
4. Other buttons can be set in the same manner.

If the battery cable is disconnected, or if the fuse blows, the radio memory will be cancelled. In that case, reset the desired stations.

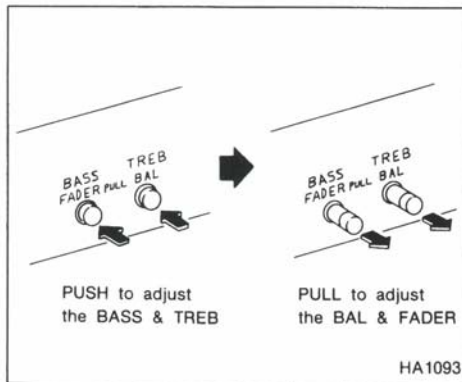

Adjusting tone quality

Push then turn the BASS and TREB (TREBLE) control knobs to obtain the most pleasant sound.

Adjusting speaker sound balance

Pull then turn the BALANCE (BAL) control knob to adjust the volume between the right and left speakers.

FADER volume control

Pull then turn the FADER control knob to

adjust the volume between the front and rear speakers.

Cassette tape operation

Turn the ignition key to "ACC" or "ON", then lightly insert the cassette tape into the tape door.

The cassette tape will be automatically pulled into the player.

The radio will turn off and the cassette tape will begin to play.

Do not force the cassette tape into the tape door.

Pressing strongly could cause player damage.

The cassette tape will automatically change directions to play the other side when the first side is completed.

PLAY button

You may push the PLAY button when:

- the tape has stopped playing,
- the tape has been fast forwarded,
- the tape has been rewound,
- the radio is on.

Fast forwarding or rewinding the tape

Push either the FF (forward) or REW (rewind) button for the desired direction.

The indicator light on the switch will come on.

Push either the APS FF or APS REW button while the cassette tape is playing. The tape will run quickly, and stop and play at the next program. The indicator light flashes "ON" and "OFF" while searching the program.

This system searches at the blank intervals between selections. If there is a blank interval within one program or there is no interval between programs, the system may not search correctly.

Changing the direction of tape play

Push the PROG (program) select button.

Dolby NR (noise reduction)

Push the  "DOLBY NR" button for DOLBY NR encoded tapes to reduce high frequency tape noise. The indicator will glow on the button.

Dolby NR is manufactured under license from Dolby Laboratories Licensing Corporation. "Dolby NR" and the double-D symbol are trademarks of Dolby Laboratories Licensing Corporation.

Metal or chrome tape usage

The cassette player will be automatically set to high performance play when playing a metal or chrome cassette tape.

The indicator will come on when playing a metal or chrome cassette tape.

Stopping and ejecting the cassette tape

Push the eject button.

Precautions on cassette player operation

- **To maintain good quality sound, NISSAN recommends that you use cassette tapes of 60 minutes or shorter in length.**
- **Cassette tapes should be removed from the player when not in use. Store cassettes in their protective cases and away from direct sunlight, heat, moisture and magnetic sources.**

Direct sunlight can cause the cassette to become deformed. The use of deformed cassettes may cause the cassette to jam in the player.

- **Do not use cassettes that have labels which are peeling and loose. If used, the label could jam in the player.**
- **If a cassette has loose tape, insert a pencil through one of the cassette hubs and rewind the tape firmly around the hubs. Loose tape may cause tape jamming and wavering sound quality.**
- **Over a period of time, the playback head, capstan and pinch roller may gather a tape coating residue as the tape passes over the head. This residue accumulation can cause a weak or wavering sound and should be removed periodically with a head cleaning tape. If the residue is not removed periodically, the player may need to be disassembled for cleaning.**

AM-FM RADIO WITH CASSETTE PLAYER

Radio operation

Push the ON.VOL knob to listen to the radio and tune in the desired station.

Turn the ON.VOL knob to adjust the volume.

Inserting a cassette tape into the cassette player while the radio is on will turn off the radio and turn on the cassette player.

The electronic tuning radio has a DIVERSITY reception system. The FM signal can reflect off of buildings or mountains. This causes offensive noise. The DIVERSITY system employs two antennas; one is a rod type antenna and the other is a printed antenna on the rear window. This system automatically switches to the antenna which receives less noise. Thus the radio provides high quality reception.

Selecting the desired band

Push the band select button (FM/AM) to change from AM to FM reception.

The stereo indicator will glow during FM stereo reception. When the stereo broadcast signal is weak, the radio will automat-

ically change from stereo to monaural reception.

Tuning

Manual tuning

Push down either manual tuning button



SCAN tuning

Push the SEEK/SCAN tuning button  for more than 1.5 seconds. SCAN tuning begins from low to high frequencies and stops at each broadcasting station for five seconds. Pushing the button again during this five second period will stop SCAN tuning and the radio will remain tuned to that station.

SEEK tuning

Push the SEEK/SCAN tuning button  for less than 1.5 seconds. SEEK tuning begins from low to high frequencies and stops at the next broadcasting station.

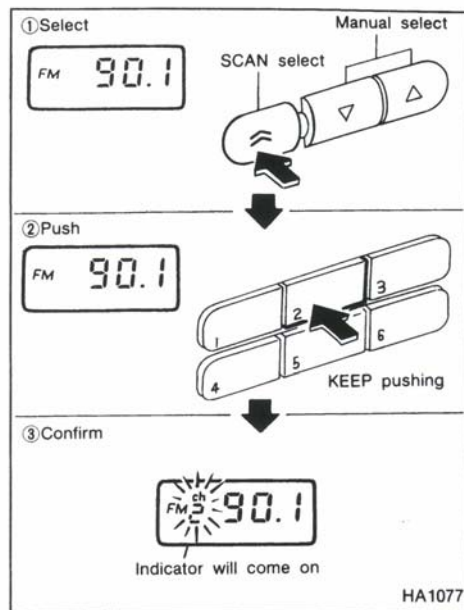

Station memory operations

Six stations can be set for each band.

1. Tune to the desired station.
2. Push the desired select button for more

than 2 seconds. (For example in the diagram ch2 is to be memorized. The radio mutes when the select button is pushed.)

- The indicator, "ch2" will then come on and the sound will resume. Memorizing is now complete.
- Other buttons can be set in the same manner.

If the battery cable is disconnected, or if the fuse blows, the radio memory will be cancelled. In that case, reset the desired stations.

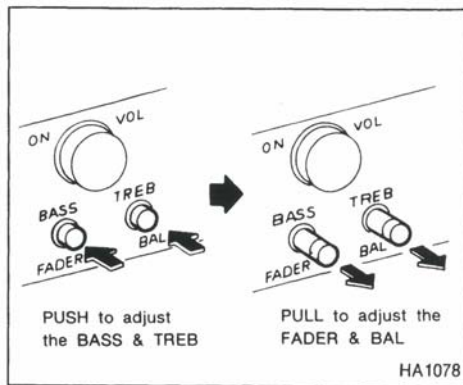

Adjusting tone quality

Push then turn the BASS and TREB (TREBLE) control knob to obtain the most pleasant sound.

Adjusting speaker sound balance

Push then pull the BALANCE (BAL) control knob to adjust the volume between the right and left speakers.

FADER volume control

Push then pull the FADER control knob to

adjust the volume between the front and rear speakers.

Cassette tape operation

Turn the ignition key to "ACC" or "ON", then lightly insert the cassette tape into the tape door.

The cassette tape will automatically pull into the player.

Do not force the cassette tape into the tape door.

Pressing strongly could cause player damage.

The cassette tape will automatically change directions to play the other side when the first side is completed.

- To maintain good quality sound, NISSAN recommends that you use cassette tapes of 60 minutes or shorter in length.
- Cassette tapes should be removed from the player when not in use. Store cassettes in their protective cases and away from direct sunlight, heat, moisture and magnetic sources.

Direct sunlight can cause the cassette to become deformed. The use of deformed

cassettes may cause the cassette to jam in the player.

- **Do not use cassettes that have labels which are peeling and loose. If used, the label could jam in the player.**
- **If a cassette has loose tape, insert a pencil through one of the cassette hubs and rewind the tape firmly around the hubs. Loose tape may cause tape jamming and wavering sound quality.**
- **Over a period of time, the playback head, capstan and pinch roller may collect a tape coating residue as the tape passes over the head. This residue accumulation can cause weak or wavering sound, and should be removed periodically with a head cleaning tape. If the residue is not removed periodically, the player may need to be disassembled for cleaning.**

Fast forwarding or rewinding the tape

Push either the FF (forward) or REW (rewind) button for the desired direction.

The indicator light on the switch will come on.

APS fast forwarding or APS rewinding the tape

Push either the APS FF or APS REW button while the cassette tape is playing. The tape will run quickly, and stop and play at the next program. The indicator light flashes "ON" and "OFF" while searching the program.

This system searches at the blank intervals between selections. If there is a blank interval within one program or there is no interval between programs, the system may not search correctly.

Changing the direction of tape play

Push the PROG (program) select button.

Playing and stopping the cassette tape

Pushing the PLAY/STOP button while the cassette tape is playing stops the tape. Pushing the button again plays the tape.

Dolby NR (noise reduction)

Push the  "DOLBY NR" button for Dolby NR encoded tapes to reduce high

frequency tape noise. The indicator will come on.

Dolby NR is manufactured under license from Dolby Laboratories Licensing Corporation. "DOLBY NR" and the double-D symbol are trademarks of Dolby Laboratories Licensing Corporation.

Metal or chrome tape usage

The cassette player will be automatically set to high performance play when playing a metal or chrome cassette tape.

Ejecting the cassette tape

Push the eject button.

The cassette tape will automatically come out.

AM-FM RADIO WITH CASSETTE PLAYER AND COMPACT DISC PLAYER

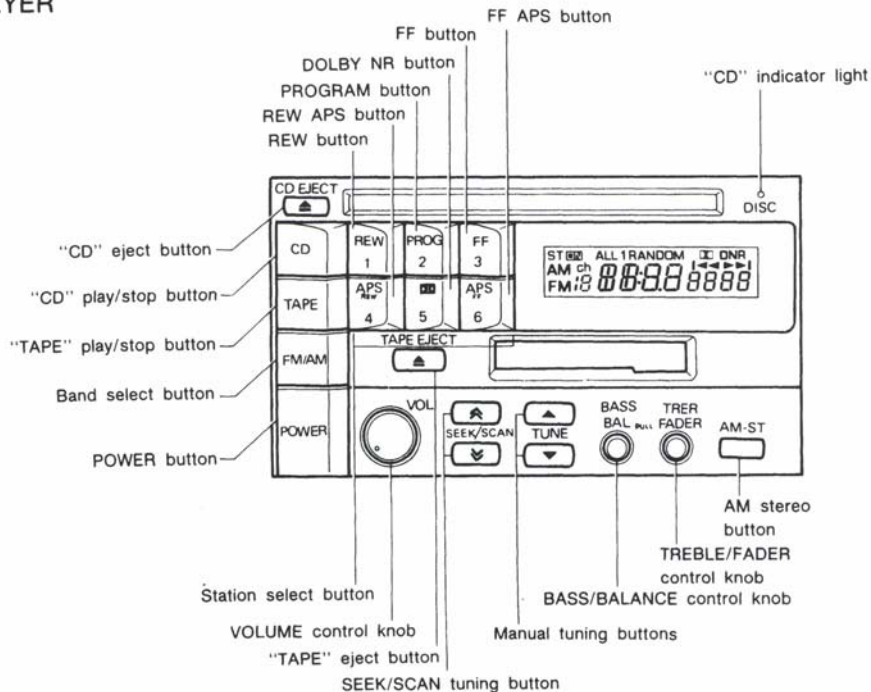

HA1079

AM-FM RADIO WITH CASSETTE PLAYER AND COMPACT DISC PLAYER

Head unit

The radio has an FM Diversity reception system, which employs two antennas. One is a rod type antenna; the other is an antenna printed on the window. This system automatically switches to the antenna which is receiving less noise.

Noise is further reduced through the use of the Dynamic Noise Reduction (DNR) system, which adds to the high quality reception.

The tape deck employs an amorphous head which allows for improved reproduction of high frequency ranges. Noise is also greatly reduced by the combined use of the Dolby NR (noise reduction) system. The auto loudness circuit enhances the low frequency range automatically in both radio reception and tape playback.

Power button

Turn the ignition key to "ACC" or "ON", then push the POWER button while the system is off to call up the mode (radio, tape

or CD) which was playing immediately before the system was off. When no CD or tape is loaded, the last available mode is called up. While the system is on, pushing the POWER button turns the system off.

To turn the radio off, press the POWER button.

VOL (volume) control knob

Turn the VOLUME control knob to adjust the volume.

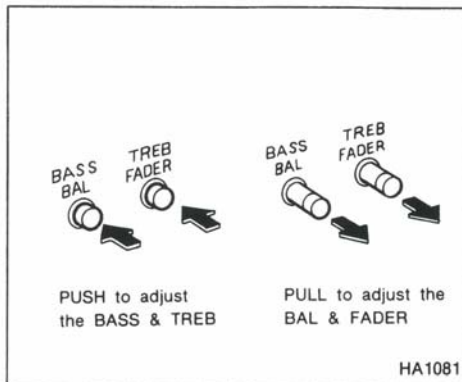

Adjusting tone quality

Push then turn the BASS and TREB (TREBLE) control knobs to obtain the most pleasant sound.

Adjusting speaker sound balance

Push then pull the BALANCE (BAL) control knob to adjust the volume between the right and left speakers.

FADER volume control

Push then pull the FADER control knob to

adjust the volume between the front and rear speakers.

RADIO OPERATION

FM/AM button

Pushing the FM/AM button will change the band.

When FM/AM button is pushed while the ignition switch is at "ACC" or "ON", the radio will come on at the station last played.

The last station played will also come on when the power button is turned to ON.

If a compact disc or tape is inserted when the power button is turned to ON, the compact disc or tape will automatically be turned off and the last radio station played will come on.

AM-ST button

When the AM-ST button is turned on, the "ON" indicator will light up and the AM stereo will come on.

The FM/AM stereo indicator "ST" will glow during FM/AM stereo reception. When the stereo broadcast signal is weak, the radio



will automatically change from stereo to monaural reception.

TUNE button  



Use these buttons for manual tuning. To move quickly through the channels, hold either of the tuning buttons down for more than 1.5 seconds.

SCAN/SEEK buttons  

SCAN tuning

Push the SEEK/SCAN tuning button  or  for more than 1.5 seconds. SCAN tuning begins from low to high frequencies and stops at each broadcasting station for five seconds. Pushing the button again during this five second period will stop SCAN tuning and the radio will remain tuned to that station.

SEEK tuning

Push the SEEK/SCAN tuning button  or  for less than 1.5 seconds. SEEK tuning begins from low to high frequencies and stops at next broad casting station.

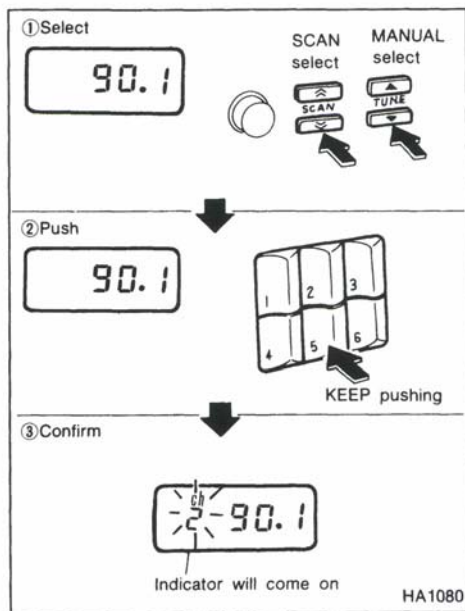

Station memory operations

Six stations can be set for each band.

1. Tune to the desired station.
2. Push the desired select button for more

than 3 seconds. (For example in the diagram ch2 is to be memorized. The radio ceases emitting sounds when the select button is pushed.)

3. The indicator, "ch2" will then come on and the sound will resume. Memorizing is now complete.
4. Other buttons can be set in the same manner.

If the battery cable is disconnected, or if the fuse blows, the radio memory will be cancelled. In that case, reset the desired stations.

Cassette tape operation

Turn the ignition key to "ACC" or "ON", then lightly insert the cassette tape into the tape door. The cassette tape will be automatically pulled into the player.

The radio or CD will turn off (if it is on) and the cassette tape will begin to play.

Do not force the cassette tape into the tape door.

Pressing strongly could cause player damage.

When the POWER button  POWER



is pushed after the tape has been played and the system has been turned off, the tape will start to play. (When the system is turned off by the TAPE EJECT button , however, the previous mode will begin playing.)

TAPE button 

- When this button is pushed with the system turned off and a tape loaded, the system will come on and the tape will play.
- When this button is pushed with either the radio or compact disc turned on and the tape loaded, the compact disc or the radio will automatically be turned off and the tape will play.

While the tape is playing, pushing the TAPE button stops the tape. Pushing the button again allows the tape to play.

FF (fast forward), REW (rewind) button  



Push the FF (fast forward) button to fast forward the tape. To rewind the tape, push the REW (rewind) button. Either the indicator light "APS  FF 

" or "APS  REW 

come on when the FF or REW function is started.

APS FF, APS REW button  

When the APS FF button is pushed while the tape is being played, the next program will start to play from the beginning. Push the APS FF button several times to skip through programs. The tape will advance the number of times the button is pushed (up to 9 programs).

When the APS REW button is pushed once, the program being played starts over from the beginning. Push several times to fast rewind programs. The tape will go back the number of times the button is pushed. Either the indicator light "APS  " or "APS  " will come on when the APS FF or APS REW function is started.

This system searches at the blank intervals between selections. If there is a blank interval within one program or there is no interval between programs, the system may not search correctly.

PROG (program) button 

Push the PROG (program) button to change the tape side while the tape is being played.

The cassette tape will automatically change directions to play the other side when the first side is completed.

Dolby NR (noise reduction) button 

Push the  "DOLBY NR" button for Dolby NR encoded tapes to reduce high frequency tape noise. The indicator will come on.

Dolby NR is manufactured under license from Dolby Laboratories Licensing Corporation. "DOLBY NR" and the double-D symbol are trademarks of Dolby Laboratories Licensing Corporation.

TAPE EJECT button 

When this button is pushed with the tape loaded, the tape will be ejected.

When the tape is ejected while it is being played, the system will be turned off.

Precautions on cassette player operation

- **To maintain good quality sound, NISSAN recommends that you use cassette tapes of 60 minutes or shorter in length.**

- **Cassette tapes should be removed from the player when not in use. Store cassettes in their protective cases and away from direct sunlight, heat, moisture or magnetic sources.**

Direct sunlight can cause the cassette to become deformed. The use of deformed cassettes may cause the cassette to jam in the player.

- **Do not use cassettes that have peeling or loose labels. If used, the label could jam in the player.**
- **If a cassette has loose tape, insert a pencil through one of the cassette hubs and rewind the tape firmly. Loose tape may cause jamming and wavering sound quality.**
- **Over a period of time, the playback head, capstan and pinch roller may gather a tape coating residue as the tape passes over the head. This residue accumulation can cause a weak or wavering sound and should be removed periodically with a head cleaning tape.**

If the residue is not removed periodically, the player may need to be disassembled for cleaning.

COMPACT DISC (CD) PLAYER OPERATION

Turn the ignition key to the "ACC" or "ON" position and insert the compact disc into the slot with the label side facing up. The compact disc will be guided automatically into the slot and start playing.

If the radio or tape is already operating, it will automatically turn off and the compact disc will play.

Forcing in the compact disc will damage the player.

If the system has been turned off while the compact disc was playing, pushing the POWER button will start the compact disc. (When the system is turned off by the CD EJECT button  , however, the previous mode will begin.)



CD button 

When this button is pushed with the system off and the compact disc loaded, the system will turn on and the compact disc will start to play.

When this button is pushed with the compact disc loaded but the tape or the radio

playing, the tape or radio will automatically be turned off and the compact disc will start to play.

When this button is pushed while the compact disc is playing, the compact disc will stop playing. When this button is pushed with the compact disc stopped, the compact disc will start to play.

FF (fast forward), REW (rewind) button  

When the FF (fast forward) or REW (rewind) button is pushed while the compact disc is being played, the compact disc will play while fast forwarding or rewinding. When the button is released, the compact disc will return to normal play speed.

APS FF, APS REW button  

When the APS FF button is pushed while the compact disc is being played, the program next to the present one will start to play from its beginning. Push several times to skip through programs. The compact disc will advance the number of times the button is pushed. (When the last program on the compact disc is skipped through, the first program will be played.) When the APS

REW button is pushed, the program being played returns to its beginning. Push several times to skip back through programs. The compact disc will go back the number of times the button is pushed.

PROG (program) button

When this button is pushed while the compact disc is being played, play pattern will change as follows:

ALL: All the programs will be played repeatedly in sequence.

1: Only one program (the one being played when the PROG button is pushed) will be repeated.

RANDOM: Programs will be played at random, not following the sequence on the compact disc.

(no mark): All the programs will be played in sequence and stop when the last program is finished.

- **RANDOM** The same program may be repeated twice.
- **When the compact disc is ejected, the play pattern will automatically change to ALL.**

CD EJECT button

When the CD EJECT button is pushed with the compact disc loaded, the compact disc will be ejected.

When this button is pushed while the compact disc is being played, the compact disc will come out and the system will turn off.

If the compact disc comes out and is not removed, it will be pulled back into the slot to protect it.

DISC indicator light

This light comes on when the compact disc is loaded.

CAUTION:

- **During cold weather or rainy days, the player malfunction due to the humidity. If this occurs, remove the CD and dehumidify or ventilate the player completely.**
- **The player may skip while driving on rough roads.**
- **The CD player sometimes cannot function when the compartment temperature is extremely high. Decrease the temperature before use.**

- **Do not expose the CD to direct sunlight.**

CB RADIO OR CAR PHONE

POWER ANTENNA

The antenna will automatically extend when the radio is turned on, and retract when switched off. If the radio is left on, the antenna will retract and extend with the ignition key "OFF-ON" operation.

CAUTION:

- Before turning the radio on, make sure that there is no one near the antenna outlet and there is enough space for it to extend.
- To prevent damage, be sure that power antenna is fully retracted before the vehicle enters an automated car wash.

When installing a CB ham radio or a car phone in your NISSAN, be sure to observe the following cautions, otherwise the new equipment may adversely affect the Multiport fuel injection system and other electronic parts.

CAUTION:

- Keep the antenna as far as possible away from the Electronic Control Unit.
- Also keep the antenna wire more than 8 inches (20 cm) away from the E.F.I. harness. Do not route the antenna wire next to any harness.
- Adjust the antenna standing-wave ratio as recommended by the manufacturer.
- Connect the ground wire from the CB radio chassis to the body.
- For details, consult a NISSAN dealer.

MEMO

4 Starting and driving

Precautions when starting and driving.....	4-2
Drinking alcohol/drugs and driving.....	4-3
Ignition switch	4-3
Before starting the engine.....	4-5
Driving with automatic transmission.....	4-5
Driving with manual transmission	4-9
Starting the engine.....	4-10
Parking brake	4-11
Cruise control	4-12
Break-in schedule	4-13
Economy hints	4-14
Parking/Parking on hills.....	4-15
Precautions when driving	4-16
Anti-lock brake system.....	4-16
Cold weather driving cautions.....	4-17



PRECAUTIONS WHEN STARTING AND DRIVING

EXHAUST GAS (Carbon Monoxide)

WARNING:

Do not breathe exhaust gases; they contain colorless and odorless carbon monoxide. Carbon monoxide is dangerous. It can cause unconsciousness or death.

- If you suspect that exhaust fumes are entering the vehicle, drive with all windows fully open, and have the vehicle inspected immediately.
- Do not run the engine in closed spaces such as a garage for any longer than is absolutely necessary.
- Do not park the vehicle with the engine running for any extended length of time.
- Keep the trunk lid, or back door closed while driving, otherwise exhaust gases could be drawn into the passenger compartment. If you must drive in this manner for some reason, take the following steps.
 1. Open all the windows.
 2. Set the air recirculate switch "OFF" and the fan control at "high" to circulate the air.

- If electrical wiring or other cable connections must pass to a trailer through the seal on the trunk lid or the body, follow the manufacturer's recommendation to prevent carbon monoxide entry into the vehicle.
- If a special body or other equipment is added for recreational or other usage, follow the manufacturer's recommendation to prevent carbon monoxide entry into the vehicle. (Some recreational vehicle appliances such as stoves, refrigerator, heaters, etc. may also generate carbon monoxide.)
- The exhaust system and body should be inspected by a qualified mechanic whenever:
 - a. The vehicle is raised for service.
 - b. You suspect that exhaust fumes are entering into the passenger compartment.
 - c. You notice a change in the sound of the exhaust system.
 - d. You have had an accident involving damage to the exhaust system, underbody, or rear of the vehicle.

THREE-WAY CATALYST

The three-way catalyst is an emission control device installed in the exhaust system. Exhaust gases in the converter are burned at high temperatures to help reduce pollutants.

WARNING:

- The exhaust gas and the exhaust system are very hot. While the engine is running, keep people or flammable materials away from the exhaust pipe.
- Do not stop or park the vehicle over flammable materials such as dry grass, waste paper or rags, as they may burn easily.

To help prevent damage

- Do not use leaded gasoline.

Deposits from leaded gasoline will seriously reduce the three-way catalyst's ability to help reduce exhaust pollutants.
- Keep your engine tuned up. Malfunctions in the ignition, fuel injection, or electrical systems can cause overrich fuel flow into the converter, causing it to overheat. Do not keep driving if the en-

DRINKING ALCOHOL/DRUGS AND DRIVING

WARNING:

Alcohol in the blood stream reduces coordination, delays reaction time and impairs judgement. Driving after drinking alcohol increases the likelihood of being involved in an accident injuring yourself and others. Additionally, if you are injured in the accident alcohol can increase the severity of injury.

Nissan is committed to safe driving. But, you must choose not to drive under the influence of alcohol. Every year thousands of people are injured or killed in alcohol related accidents. Although the local laws vary on what is considered to be legally intoxicated, the fact is that alcohol affects all people differently and most people underestimate the effects of alcohol.

Remember, drinking and driving don't mix! And that's true for drugs too (over the counter, prescription, and illegal drugs). Don't drive if your ability to operate your vehicle is impaired by alcohol, drugs, or some other physical condition.

gine misfires, or if noticeable loss of performance or other unusual operating conditions are detected. Have the vehicle inspected promptly by an authorized NISSAN dealer.

- Avoid driving with an extremely low fuel level. Running out of fuel could cause the engine to misfire, damaging the three-way catalyst.
- Do not race the engine while warming it up.
- Do not push or tow your vehicle to start the engine.

IGNITION SWITCH

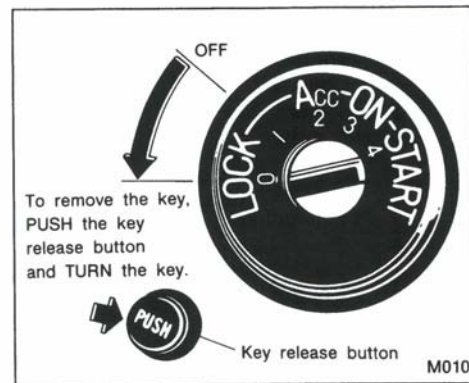

To remove the key, PUSH the key release button and TURN the key.

The switch includes an anti-theft steering lock device.

"LOCK" Normal parking position (0)

The ignition key can only be removed at this position.

To turn the ignition key to "LOCK" from "ACC" or "ON", turn the key to "OFF" and press in the key release button, then turn the key to "LOCK".

On automatic transmission models, move the shift lever to the "P" position before pressing in the key release button.

The ignition lock is designed so that the key cannot be turned to "LOCK" and removed until the shift lever is moved to the "P" position.

The shift lever is designed so that it cannot be moved out of "P" and into any of the other gear positions if the ignition key is turned to either "ACC" or "OFF" or if the key is removed from the switch.

The shift lever can only be moved if the ignition switch is in the "ON" position, and the foot brake pedal is depressed.

WARNING:

To lock the steering wheel, remove the key. To unlock the steering wheel, insert the key and turn it gently while rotating the steering wheel slightly right and left.

Never remove the key while driving. If the key is removed, the steering wheel will lock. This may cause the driver to lose control of the vehicle and could result in serious vehicle damage or personal injury.

"OFF" (1)

The engine can be turned off without locking the steering wheel.

"ACC" (Accessories) (2)

This position activates electrical accessories such as the radio when the engine is not running.

"ON" Normal operating position (3)

This position turns on the ignition system and the electrical accessories.

"START" (4)

This position activates the starter motor, starting the engine.

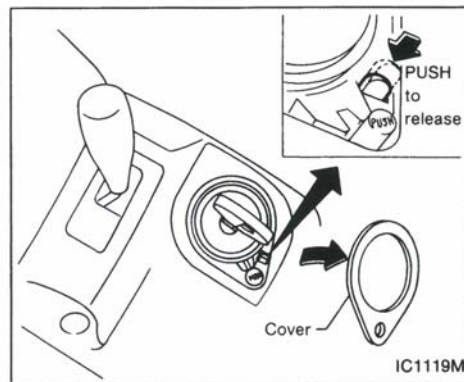

Emergency release lever (Automatic transmission model)

When the battery charge is low, pushing the key release button may not release the key even if the shift lever is in "P".

Using a suitable flat edged tool, remove the cover around the key. Under the cover there is a lever for emergency use.

BEFORE STARTING THE ENGINE

- Make sure the area around the vehicle is clear.
- Maintenance items listed here should be checked periodically, e.g., each time you check engine oil.
- Check that all windows and lights are clean.
- Visually inspect tires for their appearance and condition. Also check tires for proper inflation.
- Lock all doors.
- Position seat and adjust head restraints.
- Adjust inside and outside mirrors.
- Fasten seat belts and ask all passengers to do likewise.
- Check the operation of warning lights when key is turned to the "ON (3)" position.

Move the lever in the arrowed direction. Now, pushing the key release button will allow removal of the key with the shift lever positioned in "P". Use the release button only in an emergency.

DRIVING WITH AUTOMATIC TRANSMISSION

The automatic transmission in your vehicle (if so equipped) is electronically controlled by a microcomputer to produce maximum power and smooth operation.

Shown on the following pages are the recommended operating procedures for this transmission. Follow these procedures for maximum vehicle performance and driving enjoyment.

Starting the vehicle

- After starting the engine, fully depress the foot brake pedal before shifting the selector lever to the "D", "R", "2" or "1" position. Be sure the vehicle is fully stopped before attempting to shift the selector lever.

This automatic transmission is designed so that the foot brake pedal MUST be depressed before shifting from "P" to any drive position while the ignition switch is "ON".

The shift lever cannot be moved out of "P" and into any of the other gear positions if the ignition key is turned to "ACC" or "OFF" or if the key is removed from the switch.

1. Keep the foot brake pedal depressed and shift into a driving gear.
 2. Release the parking brake and foot brake, then gradually start the vehicle in motion.
- **Cold engine idle speed is high, so use caution when shifting into a forward or reverse gear before the engine has warmed up.**
 - **Avoid revving up the engine while the vehicle is stopped. This could cause unexpected vehicle movement.**

Driving precautions

To help prevent transmission damage:

- **Do not depress the accelerator pedal while shifting from "P" or "N" to "R", "D", "2" or "1". Always depress the brake pedal until shifting is completed.**
- **Never shift to "P" or "R" while vehicle is moving.**
- **When stopping the vehicle on an uphill grade, do not hold the vehicle by depressing the accelerator pedal. The foot brakes should be used for this purpose.**

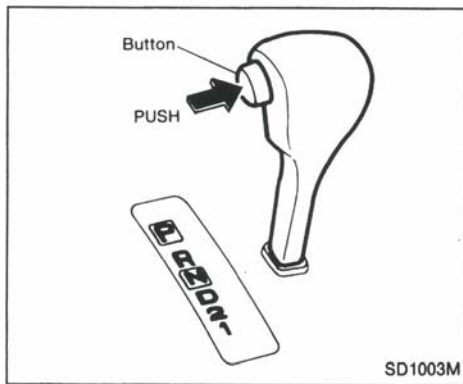

Push the button to shift into "P", "R" or from "D" to "2". All other positions can be selected without pushing the button.

"P" (Park):

Use this selector position when the vehicle is parked or when starting the engine. Always be sure the vehicle is at a complete stop. For maximum safety, depress the brake pedal, then push in the select lever button and move the lever to the "P" position. Apply the parking brake. When parking on a hill, apply the parking brake first, then shift the lever into the "P" position.

"R" (Reverse):

Use this position to back up. Always be sure the vehicle is completely stopped. With the brake pedal depressed, push in the select lever button and move the lever to the "R" position

"N" (Neutral):

Neither forward nor reverse gear is engaged. The engine can be started in this position. You may shift to "N" and restart a stalled engine while the vehicle is moving.

"D" (Drive):

Use this position for all normal forward driving.

"2" (Second gear):

Use for hill climbing or engine braking on downhill grades.

VG30E engine models:

Do not exceed 69 MPH (111 km/h) in the "2" position.

VE30DE engine models:

Do not exceed 74 MPH (119 km/h) in the "2" position.

"1" (Low gear):

Use this position when climbing steep hills slowly or driving slowly through deep snow, sand or mud, or for maximum engine braking on steep downhill grades.

VG30E engine models:

Do not exceed 38 MPH (61 km/h) in the "1" position.

VE30DE engine models:

Do not exceed 41 MPH (66 km/h) in the "1" position.

Accelerator downshift

— In "D" position —

For rapid passing or hill climbing, fully depress the accelerator pedal to the floor. This shifts the transmission down into second gear or first gear, depending on the vehicle speed.

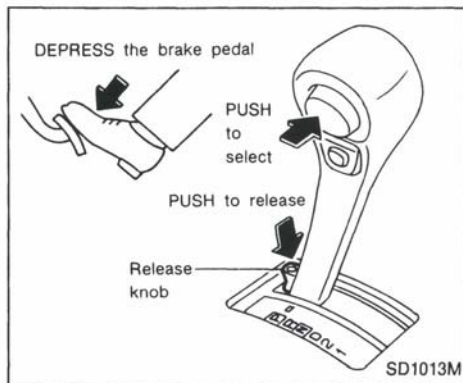

Shift lever release knob

If the battery charge is low, the shift lever may not be moved from the "P" position when the brake pedal is depressed and the shift lever knob pushed.

To move the shift lever, push the release knob and shift lever button. The shift lever can be moved to Neutral ("N").

If there is any problem moving the lever out of "P", have your NISSAN dealer check the automatic transmission system as soon as possible.

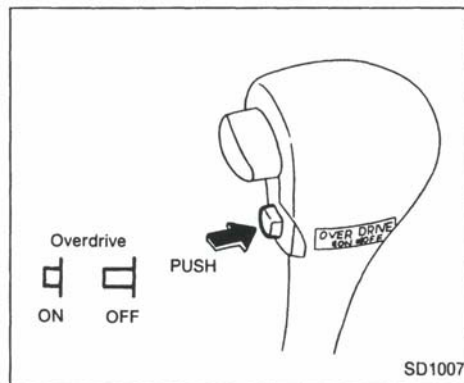

Overdrive switch

ON: For normal driving, push the overdrive switch ON with the selector switch in the "D" position. The transmission is upshifted into OVERDRIVE as the vehicle speed increases.

The overdrive will not engage until the engine has warmed up.

OFF: For driving up and down long slopes where engine "braking" would be advantageous, push the switch OFF . When cruising at a low speed

or climbing a gentle slope, you may feel shift shocks as the transmission shifts between 3rd and overdrive repeatedly. In this case, set the overdrive switch in the OFF position. The indicator light will come on at this time.

When driving conditions change, reset the overdrive switch in the ON position.

Remember not to drive at high speeds for extended periods of time with the overdrive switch set in the OFF position. This reduces the fuel economy.

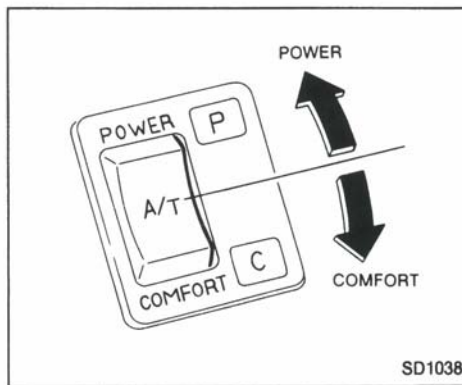

Automatic transmission mode switch

Three different driving pattern modes are available on this automatic transmission, AUTO, COMFORT and POWER. Each mode is designed to maximize driving performance under different driving conditions. These modes can be selected by pushing the mode switch (located on the center console) to the appropriate position, as shown above.

AUTO MODE:

For normal driving (The Shift Pattern automatically changes). Push the automatic transmission mode switch to the AUTO position. This is the most effective pattern mode for routine, stop-and-go driving, or driving on the freeway, when you do not want to repeatedly change particular driving patterns. Normally, the transmission shifts in the COMFORT driving pattern. When the accelerator pedal is quickly depressed, the transmission may shift into the POWER driving pattern. The "P" indicator light comes on.

COMFORT MODE:

For comfortable driving. Push the automatic transmission mode switch to the COMFORT position. The "C" indicator light will come on. The transmission shifts into the COMFORT driving pattern. As the transmission shifts at lower engine revolutions (lower vehicle speed), a silent and comfortable ride can be enjoyed.

POWER MODE:

For powerful acceleration in sporty driving or driving up long slopes. Push the automatic transmission mode switch to the

POWER position. The "P" indicator light will come on. The transmission shifts into the POWER driving pattern. As the transmission may always shift in higher engine revolution (higher vehicle speed), you can obtain powerful acceleration in passing or climbing.

Fail-safe

When the Fail-safe operation occurs, the next time the key is turned to the "ON" position, the "P" indicator light will blink for approximately 8 seconds after coming on for 2 seconds. While the vehicle can be driven under these circumstances please note that the gears in the automatic transmission will be locked in third gear.

If the vehicle is driven under extreme conditions, such as excessive wheel spinning and subsequent hard braking, the Fail-safe system may be activated. This will occur even if all electrical circuits are functioning properly. In this case, turn the ignition key "OFF" and wait for 3 seconds. Then turn the key back to the "ON" position. The vehicle should return to its normal operating condition. If it does not return to its normal operating condition have your NISSAN dealer check the transmission and repair if necessary.

DRIVING WITH MANUAL TRANSMISSION

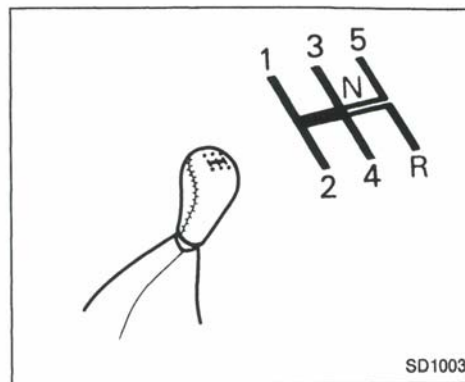

To change gears, fully depress the clutch pedal, then move the gearshift lever. After shifting, release the clutch slowly.

On the 5-speed transmission model, you cannot shift directly from 5th gear into Reverse. First shift into Neutral, then into Reverse.

If it is difficult to move the shift lever into Reverse or 1st, shift into Neutral, then release the clutch pedal and shift into Reverse or 1st again.

STARTING THE ENGINE

Driving precautions

- Do not rest your foot on the clutch pedal while driving. This may cause clutch damage.
- Stop your vehicle completely before shifting into reverse.

Suggested shift-up speeds

Shown below are suggested vehicle speeds for shifting into a higher gear. These suggestions relate to fuel economy and vehicle performance. Actual shift-up speeds will vary according to road conditions, the weather and individual driving habits.

For normal acceleration in low altitude areas [less than 4,000 ft (1,219 m)]:

Gear change	ACCEL	shift	CRUISE	shift
	point	point	point	point
	MPH (km/h)	MPH (km/h)	MPH (km/h)	MPH (km/h)
1st to 2nd	13 (24)		13 (24)	
2nd to 3rd	23 (40)		16 (29)	
3rd to 4th	33 (58)		27 (48)	
4th to 5th	39 (64)		36 (63)	

For quick acceleration when the engine is

cold or in high altitude areas [over 4,000 ft (1,219 m)]:

Gear change	MPH (km/h)
1st to 2nd	15 (24)
2nd to 3rd	25 (40)
3rd to 4th	40 (64)
4th to 5th	45 (72)

Suggested maximum speed in each gear

Downshift to a lower gear if the engine is not running smoothly, or if you need to accelerate.

Do not exceed the maximum suggested speed (shown below) in any gear. For level road driving, use the highest gear suggested for that speed. Always observe posted speed limits, and drive according to the road conditions, which will ensure safe operation. Do not overrev the engine when shifting to a lower gear as it may cause engine damage or loss of vehicle control.

Gear	MPH(km/h)
1st	30 (50)
2nd	55 (90)
3rd	80 (130)
4th	—
5th	—

1. Apply the parking brake.

2. Automatic transmission:

Move the selector lever to "P" (Park) or "N" (Neutral). ("P" preferred.)

The shift lever cannot be moved out of "P" and into any of the other gear positions if the ignition key is turned to "ACC" or "OFF" or if the key is removed from the switch.

The starter is designed not to operate if the selector lever is in one of the driving positions.

Manual transmission:

Move the gearshift lever to "N" (Neutral), and depress the clutch pedal to the floor while cranking the engine.

The starter is designed not to operate unless the clutch pedal is depressed.

3. Crank the engine **with your foot off the accelerator pedal** by turning the ignition key to "START". Release the key when the engine starts. If the engine starts, but fails to run, repeat the above procedure.

— If the engine is very hard to start in extremely cold or hot weather, depress

PARKING BRAKE

the accelerator pedal and hold it to help start the engine.

— In the summer, when restarting the engine within 30 minutes after it has been stopped, keep the accelerator pedal fully depressed while starting.

CAUTION:

Do not operate the starter for more than 15 seconds at a time. If the engine does not start, wait 10 seconds before cranking again, otherwise the starter could be damaged.

4. Warm-up

Allow the engine to idle for at least 30 seconds after starting. Drive at moderate speed for a short distance first, especially in cold weather.

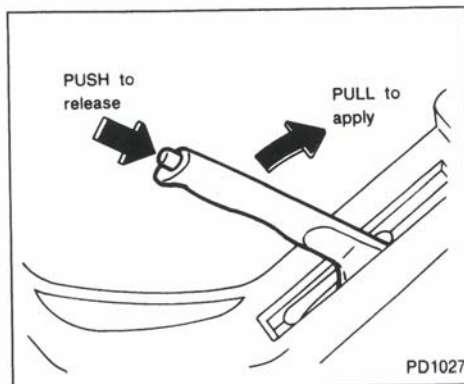

To apply: pull the lever up.

To release: pull the lever up slightly, push the button and lower completely. Before driving, be sure the parking brake warning light goes out.

CRUISE CONTROL

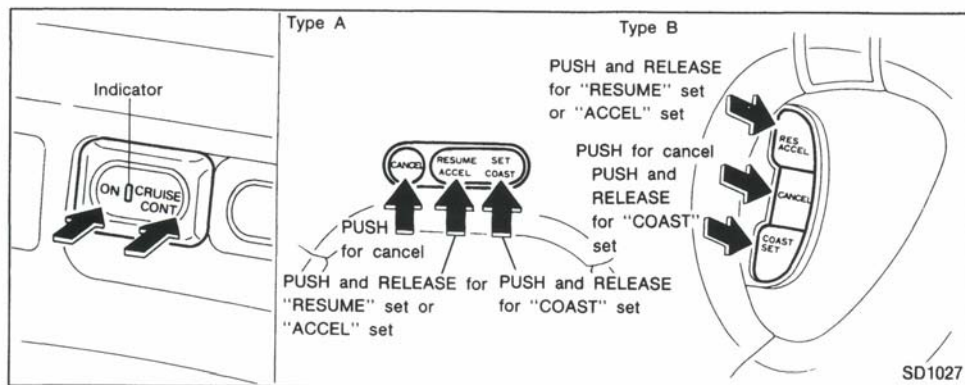

The cruise control allows driving at a speed between 30 to 89 MPH (48 to 144 km/h) without keeping your foot on the accelerator pedal.

To turn on the cruise control, push the main switch on. The indicator light on the switch will come on.

To set at cruising speed, accelerate your vehicle to the desired speed, push the SET/COAST switch and release it. (The "CRUISE" light will come on.) Take your foot off the accelerator pedal. Your vehicle will maintain the set speed.

- **To pass another vehicle**, depress the accelerator pedal. When you release the pedal, the vehicle will return to the previously set speed.
- The vehicle may not maintain the set speed when going up or down steep hills. If this happens, drive without the cruise control.

To cancel the preset speed, follow either of these three methods:

- a) Push the cancel button; The "CRUISE" light will go out.

- b) Tap the brake pedal; The "CRUISE" light will go out.

- c) Turn the main switch off. Both the "ON" indicator and "CRUISE" lights will go out.

- If you depress the brake pedal while pushing the "ACCEL" set switch and reset at the cruising speed, turn the main switch off once and then turn it on again.
- The cruise control will automatically be cancelled if the vehicle slows down below approximately 8 MPH (13 km/h).
- Depress the clutch pedal (manual transmission), or move the selector lever to "N" (automatic transmission). The "CRUISE" light will go out.

To reset at a faster cruising speed, use one of the following three methods:

- a) Depress the accelerator pedal. When the vehicle attains the desired speed, push and release the "SET/COAST" switch.
- b) Push and hold the "ACCEL" set switch. When the vehicle attains the speed you desire, release the switch.
- c) Push, then quickly release the "ACCEL"

BREAK-IN SCHEDULE

set switch. Each time you do this, the set speed will increase by about 1 MPH (1.6 km/h).

To reset at a slower cruising speed, use one of the following three methods:

- Lightly tap the brake pedal. When the vehicle attains the desired speed, push the "SET/COAST" switch and release it.
- Push and hold the "SET/COAST" switch. Release the switch when the vehicle slows down to the desired speed.
- Push, then quickly release the "SET/COAST" switch. Each time you do this, the set speed will decrease by about 1 MPH (1.6 km/h).

To resume the preset speed, push and release the "RESUME" set switch. The vehicle will resume the last set cruising speed when the vehicle speed is over 30 MPH (48 km/h).

Precautions

Avoid using the cruise control when driving under the following conditions:

- when it is not possible to keep the vehicle at set speed.

- in heavy traffic or in traffic that varies in speed.
- on winding roads, or hilly roads.
- on slippery roads (rain, snow, ice, etc.)
- in very windy areas.

CAUTION:

On manual transmission models, do not shift into neutral without depressing the clutch pedal when the cruise control is on. This could cause engine damage. If this happens, depress the clutch pedal and turn the main switch off immediately.

During the first 1,000 miles (1,600 km), follow these recommendations for the future reliability and economy of your new vehicle. Failure to follow these recommendations may result in vehicle damage or shortened engine life.

- Do not drive over 55 MPH (90 km/h) and do not run the engine over 4,000 rpm. Avoid driving for long periods at constant speed, either fast or slow.
- Do not accelerate at full throttle in any gear.
- Avoid quick starts.
- Avoid hard braking as much as possible.
- Do not tow a trailer for the first 500 miles (800 km).

ECONOMY HINTS

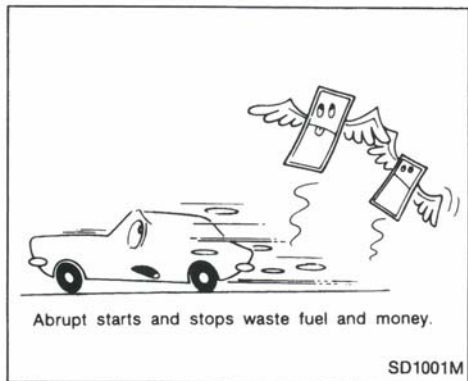

- Accelerate slowly and smoothly. Maintain cruising speeds with a constant accelerator position.
- Drive at moderate speeds on the highway. Driving at high speed will lower fuel economy.
- Avoid unnecessary stopping and braking. Maintain a safe distance behind other vehicles.
- Use a proper gear range which suits road conditions. On level roads, shift into high gear as soon as possible.
- Avoid unnecessary engine idling.
- Keep your engine tuned up.
- Follow the recommended periodic maintenance schedule.
- Keep the tires inflated at the correct pressure. Low pressure will increase tire wear and waste fuel.
- Keep the front wheels in correct alignment. Improper alignment will cause not only tire wear but also lower fuel economy.
- Air conditioner operation lowers fuel economy. Use the air conditioner only when necessary.
- When cruising at highway speeds, it is more economical to use the air conditioner and leave the windows closed to reduce drag.

PARKING/PARKING ON HILLS

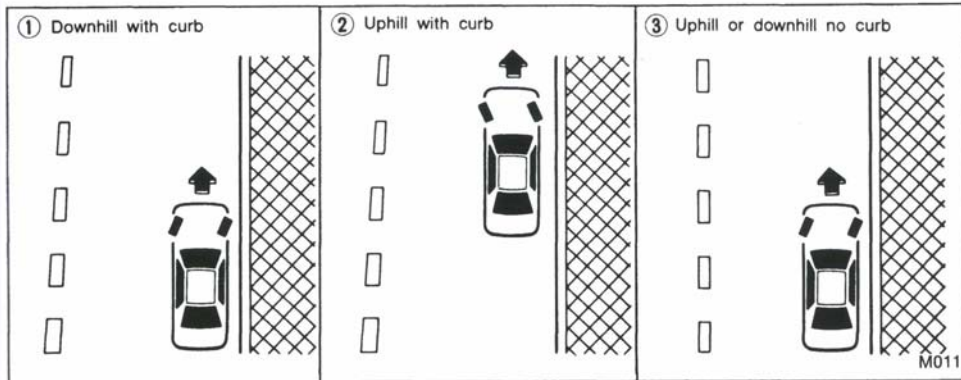

CAUTION:

Do not park the vehicle over flammable materials such as dry grass, waste paper or rags, as they may burn easily.

1. Firmly apply the parking brake.
2. **Manual transmission models:**

Place the gearshift lever in the "REVERSE" position. When parking on an uphill grade, place the gearshift lever in the "1st" position.

Automatic transmission models:

Move the gearshift lever to the "P" (PARK) position.

CAUTION:

Safe parking procedures require that both the parking brake be set and the transmission placed into "P" (park) position. Make sure the shift lever has been pushed as far forward as it can go and cannot be moved without depressing the button at the end of the lever.

3. To help prevent the vehicle from rolling into the street when parked on a sloping drive way, it is a good practice to turn the

wheels as illustrated.

- **HEADED DOWNHILL WITH CURB: ①**

Turn the wheels into the curb and move the vehicle forward until the curb side wheel gently touches the curb.

- **HEADED UPHILL WITH CURB: ②**

Turn the wheels away from the curb and move the vehicle back until the curb side wheel gently touches the curb.

- **HEADED UPHILL OR DOWNHILL, NO CURB: ③**

Turn the wheels toward the side of the road so the vehicle will move away from the center of the road if it moves.

4. Turn the ignition key to the "LOCK" position and remove the key.

CAUTION:

- **Never leave the engine running while the vehicle is unattended.**
- **Never leave children unattended in the vehicle.**

PRECAUTIONS WHEN DRIVING

● **Driving with vacuum assisted brake:**

The brake booster aids braking by using engine vacuum. If the engine stops, you can stop the vehicle by depressing the brake pedal. However, greater foot pressure on the brake pedal will be required to stop the vehicle and the stopping distance will be longer.

● **Driving with the power assisted steering:**

The power assisted steering is designed to use a hydraulic pump, driven by the engine, to assist steering.

If the engine stops or drive belt breaks, you will still have control of the vehicle. However, much greater steering effort is needed, especially in sharp turns or at low speeds.

● **Wet brakes:**

When the vehicle is washed or driven through water, the brakes may get wet. As a result, your braking distance will be longer and the vehicle may pull to one side during braking.

To dry brakes, drive the vehicle at a safe speed while lightly pressing the brake pedal to heat-up the brakes. Do this until

the brakes return to normal. Avoid driving the vehicle at high speeds until the brakes function correctly.

- Avoid resting your foot on the brake pedal while driving. This will overheat the brakes, wear out the brake linings and pads faster and reduce gas mileage.
- To help save the brakes and to prevent the brakes from overheating, reduce speed and downshift to a lower gear before going down a slope or long grade. Overheated brakes may reduce braking performance and could result in loss of vehicle control.
- While driving on a slippery surface, be careful when braking, accelerating or downshifting. Abrupt braking actions or sudden acceleration could cause the wheels to skid.

ANTI-LOCK BRAKE SYSTEM

The anti-lock brake system controls the brakes at each wheel so the wheels will not lock when braking abruptly or when braking on slippery surfaces. The system detects the rotation speed at each wheel and varies the brake fluid pressure to prevent each wheel from locking and sliding. By preventing wheel lockup, the system helps the driver maintain steering control and helps to minimize swerving and spinning on slippery surfaces.

Self-test feature

The anti-lock brake system consists of electronic sensors, electric pumps, and hydraulic solenoids controlled by a computer. The computer has a built-in diagnostic feature that tests the system each time you start the engine and move the vehicle at a low speed in forward or reverse. When the "self-test" occurs, you may hear a "clunk" noise and/or feel a "pulsation" in the brake pedal. This is normal and is not an indication of any malfunction. If the computer senses any malfunction, it switches the anti-lock brake system OFF and turns on the "ABS" brake warning light in the dashboard. The brake system will then behave normally, but without anti-lock assistance.

If the light comes on during the self check, or while you are driving, you should take your vehicle to your NISSAN dealer for repair at your earliest convenience.

Normal operation

The vehicle must be traveling at least 6 MPH (10 km/h) for the anti-lock system to work. When the anti-lock system senses that one or more wheels are close to locking up, the actuator (under the hood) rapidly applies and releases hydraulic pressure (like pumping the brakes very quickly). While the actuator is working, you may feel a pulsation in the brake pedal and hear a noise or vibration from the actuator under the hood. This is normal and indicates that the anti-lock system is working properly. However, the pulsation may indicate that road conditions are hazardous and extra care is required while driving.

WARNING:

The anti-lock brake system is a sophisticated device, but is cannot prevent accidents resulting from careless or dangerous driving techniques. It can help maintain vehicle control during braking on slippery surfaces, but remember that the stopping

distance on slippery surfaces will be longer than on normal surfaces, even with the anti-lock system. Ultimately, the responsibility for safety of self and others rests in the hands of the driver.

Tire type and condition may also affect braking effectiveness. Refer to "Wheels and tires" in the "Do-it-yourself operations" section of this manual.

COLD WEATHER DRIVING CAUTIONS

Freeing a frozen door lock

To prevent a door lock from freezing, apply de-icer or glycerin to it through the key hole. If the lock becomes frozen, heat the key before inserting it into the key hole.

Anti-freeze

In the winter when it is anticipated that the temperature will drop below 32°F (0°C), check anti-freeze (ethylene glycol base) to assure proper winter protection. For details, see "Engine Cooling System" in the "Do-it-yourself operations" section.

Battery

If the battery is not fully charged during extremely cold weather conditions, the battery fluid may freeze and damage the battery. To maintain maximum efficiency, the battery should be checked regularly. For details, see "Battery" in the "Do-it-yourself operations" section.

Draining of coolant water

If the vehicle is to be left outside without anti-freeze, drain the cooling system by opening the drain valves located under the radiator and on the engine block. Refill

before operating the vehicle. See "Changing Engine Coolant" in the "Do-it-yourself operations" section.

Tire equipment

1. The SUMMER tires are of a tread design to provide superior performance on dry pavement. However, the performance of these tires will be substantially reduced in snowy and icy conditions. If you operate your vehicle on snowy or icy roads, Nissan recommends the use on all four wheels of MUD & SNOW or ALL SEASON tires. Please consult your Nissan dealer for the tire type, size, speed rating and availability information.
2. For additional traction on icy roads, studded tires may be used. However, some provinces and states prohibit their use. Check local, state and provincial laws before installing studded tires.

Skid and traction capabilities of studded snow tires, on wet or dry surfaces, may be poorer than that of non-studded snow tires.

3. Snow chains may be used if desired. Make sure they are of proper size for the tires on your vehicle and are installed according to the chain manufacturer's

suggestions. Use chain tensioners when recommended by the tire chain manufacturer to ensure a tight fit. Loose end links of the tire chain must be secured or removed to prevent the possibility of whipping action damage to the fenders or undercarriage. In addition, drive at a reduced speed, otherwise, your vehicle may be damaged and/or vehicle handling and performance may be adversely affected.

Special winter equipment

It is recommended that the following items be carried in the vehicle during winter:

1. A scraper and stiff-bristled brush to remove ice and snow from the windows and wiper blades.
2. A sturdy, flat board to be placed under the jack to give it firm support.
3. A shovel to dig the vehicle out of snow-drifts.
4. Extra window washer fluid to refill the reservoir tank.

Driving on snow or ice

- **Wet ice (32°F, 0°C and freezing rain),**

very cold snow or ice can be slick and very hard to drive on. The vehicle will have a lot less traction or "grip" under these conditions. Try to avoid driving on wet ice until the road is salted or sanded.

- **Whatever the condition, drive with caution and accelerate gently. If accelerated too fast, the drive wheels will spin and will lose even more traction.**
- **Allow more stopping distance under these conditions. Braking should be started sooner than on dry pavement.**
- **Allow greater following distances on slippery roads.**
- **Watch for slippery spots (glare ice). These may appear on an otherwise clear road in shaded areas. If a patch of ice is seen ahead, brake before reaching it. Try not to brake while actually on the ice, and avoid any sudden steering maneuvers.**

5 In case of emergency

Flat tire	5-2
Jump starting.....	5-6
Push starting	5-7
If your vehicle overheats	5-7
Tow truck towing	5-8



FLAT TIRE

If you have a flat tire, follow the instructions below.

Stopping the vehicle

1. Safely move the vehicle off the road away from traffic.
2. Turn on the hazard warning flashers.
3. Park on a level surface and apply the parking brake. Shift the manual transmission into reverse (automatic transmission in "P").
4. Turn off the engine.

WARNING:

- **Never change tires when the vehicle is on a slope, ice or slippery areas. This is dangerous.**
- **Never change tires if oncoming traffic is close to your vehicle. Wait for professional road assistance.**
- **Raise the hood to warn other traffic, and to signal professional road assistance personnel that you need assistance.**
- **Have all passengers get out of the vehicle and stand in a safe place, away from traffic and clear of the vehicle.**

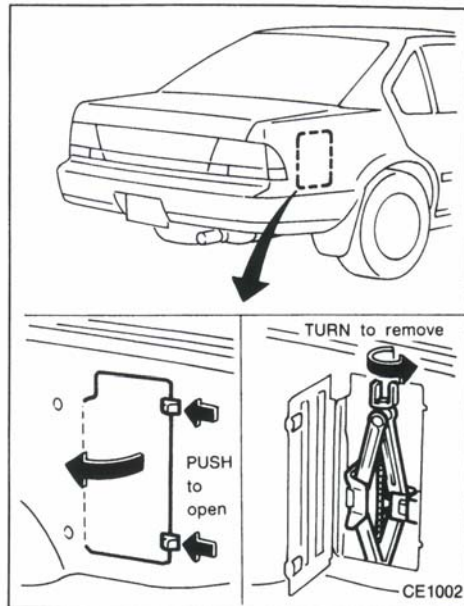
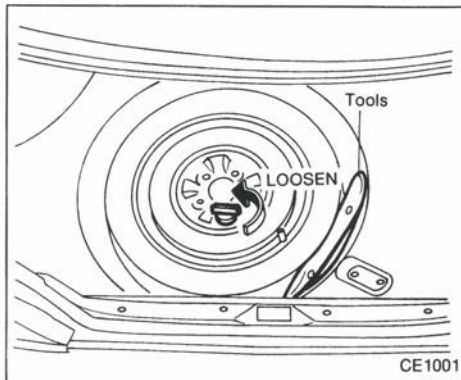

Getting the spare tire and tools

Remove jacking tools and spare tire from storage area located inside the trunk as illustrated.

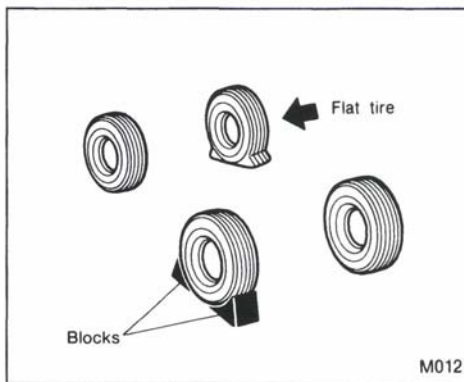

Blocking wheels

Place suitable blocks at both the front and back of the wheel diagonally opposite the flat tire to prevent the vehicle from rolling when it is jacked up.

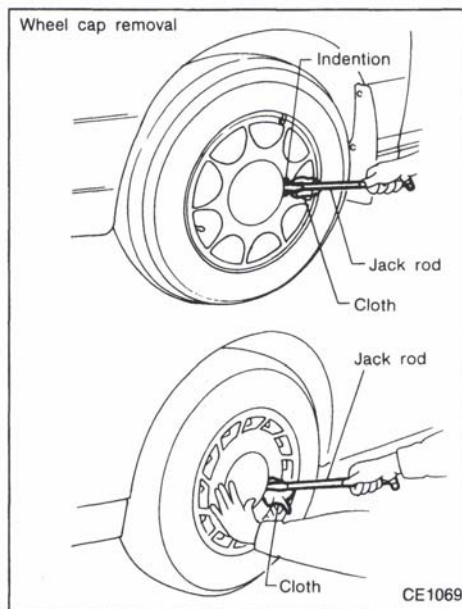

Removing wheel caps

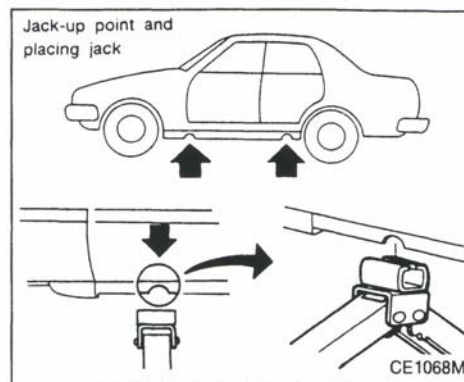

Jacking up and removing tire

To help avoid personal injury, carefully read the caution label attached to the jack body and the following instructions.

1. Place the jack directly under the jack-up point as illustrated above so that top of the jack contacts the vehicle at the jack up point. Align the center of both the jack head and the notch at the jack up point as shown. Also fit the notched portion of the vehicle in the groove of the jack head as shown.

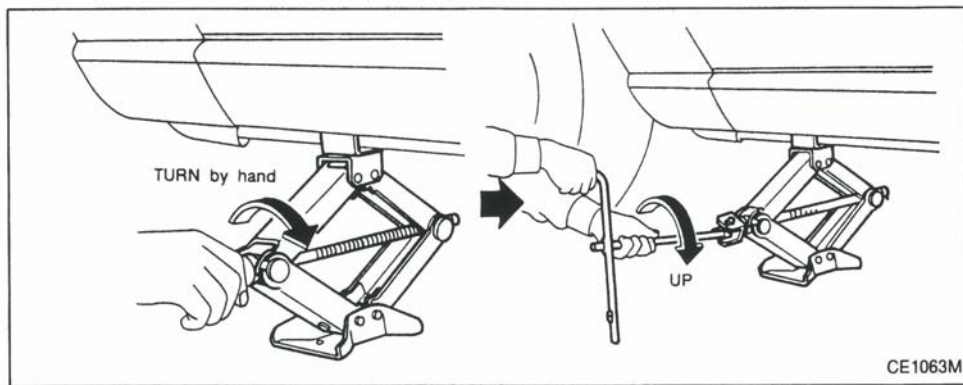

The jack should be used on level firm ground.

2. Loosen each wheel nut one or two turns by turning counterclockwise with the wheel nut wrench. **Do not remove the wheel nuts until the tire is off the ground.**
3. Carefully raise the vehicle until the tire clears the ground. Remove the wheel nuts, and then remove the tire.

WARNING:

- **Never get under the vehicle while it is supported only by the jack.**
- **Use the jack provided with your vehicle. The jack is designed only for lifting your vehicle during a tire change.**
- **Use the correct jack up points; never use any other part of the vehicle for jack support.**
- **Never jack up the vehicle more than necessary.**
- **Never use blocks on or under the jack.**

- **Do not start or run engine while vehicle is on the jack.**
- **Do not allow passengers to stay in the vehicle while it is on the jack.**
- **Do not raise the vehicle using a bumper jack.**

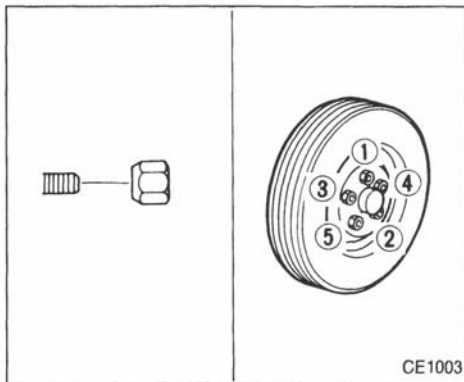

Installing wheel

The T-type spare tire is designed for emergency use. See specific instructions under the heading "Wheel and tire" in the "Do-it-yourself operations" section.

1. Clean any mud or dirt from the surface between the wheel and hub.
2. Carefully put the wheel on and tighten the wheel nuts finger tight.
3. With the wheel nut wrench, tighten wheel nuts alternately and evenly until they are tight.

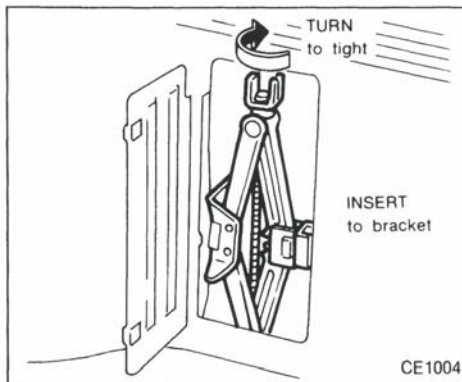

4. Lower the vehicle slowly until the tire touches the ground. Then, with the wheel nut wrench, tighten the wheel nuts securely in the sequence as illustrated.

CAUTION:

- As soon as possible tighten the wheel nuts to the specified torque with a torque wrench.

Wheel nut tightening torque:

72 to 87 ft-lb
(98 to 118 N·m)

- Adjust tire pressure to the COLD pressure.

COLD pressure:

After vehicle has been parked for three hours or more or driven less than 1 mile (1.6 km).

COLD tire pressures are shown on the tire placard affixed to the center console lid.

- Retighten the wheel nuts when the vehicle has been run for 600 miles (1,000 km) after installing the aluminum wheel.
5. Securely store the spare tire and jacking equipment in the vehicle.

- Always make sure that the spare tire and jacking equipment are properly secured after use.

Such items can become dangerous projectiles in an accident or sudden stop.

The T-type spare tire and small size spare tire are designed for emergency use. See specific instructions under the heading "Wheel and tire" in the "Do-it-yourself operations" section.

JUMP STARTING

To start your engine with a booster battery, the instructions and precautions below must be followed.

CAUTION:

- If done incorrectly, jump starting can be hazardous.
- Explosive hydrogen gas is always present in the vicinity of the battery. Keep all sparks and flames away from the battery.
- Do not allow battery fluid to come into contact with eyes, skin, cloth or painted surfaces. Battery fluid is a corrosive sulphuric acid solution which can cause severe burns. If the fluid should come into contact with anything, immediately flush the contacted area with water.
- A battery rated at above 12 volts should not be used for a booster.
- Whenever working on or near a battery, always wear suitable eye protectors (e.g., goggles or industrial safety spectacles) and remove rings, metal bands, or any other metal jewelry.
- Keep battery out of the reach of children.

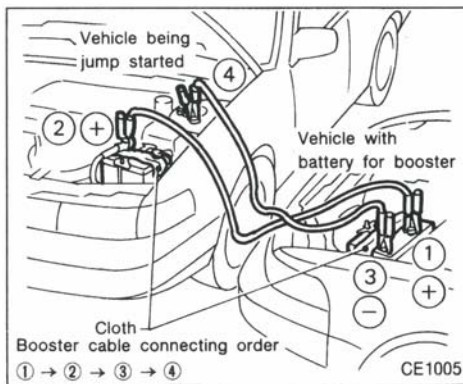

Always follow the instructions below. Failure to do so could result in damage to the charging system and cause personal injury.

1. If the booster battery is in another vehicle, position the two vehicles to bring their batteries into close proximity to each other.
2. Apply parking brake. Move the shift lever to "Neutral" (On automatic transmission models, move the lever to "P"). Switch off all unnecessary electrical systems (light, heater, air conditioner, etc.).

Do not allow the two vehicles to touch.

3. Remove vent caps on the battery (if so equipped). Cover the battery with an old cloth to reduce explosion hazard.
4. Connect jumper cables in the sequence as illustrated.

CAUTION:

- Always connect positive (+) to positive (+) and negative (-) to body ground (e.g., strut mounting bolt, etc. — not to the battery).
 - Make sure that cables do not touch moving parts in the engine compartment and that clamps do not contact any other metal.
5. Start the engine of the other vehicle and let it run for a few minutes.
 6. Keep the engine speed of the other vehicle at about 2,000 rpm, and start your engine in the normal manner.

CAUTION:

Do not keep starter motor engaged for more than 10 seconds. If the engine does not start right away, turn the key off and wait 3 to 4 seconds before trying again.

PUSH STARTING

7. After starting your engine, carefully disconnect the negative cable and then the positive cable.
8. Replace the vent caps (if so equipped). Be sure to dispose of the cloth used to cover the vent holes as it may be contaminated with corrosive acid.

CAUTION:

- **Automatic transmission models cannot be push started. This may cause transmission damage.**
- **Three-way catalyst equipped models should not be started by pushing since the three-way catalyst may be damaged.**
- **Never try to start the vehicle by towing it; when the engine starts, the forward surge could cause the vehicle to collide with the tow vehicle.**

IF YOUR VEHICLE OVERHEATS

If your vehicle is overheating (indicated by an extremely high temperature gauge reading), or if you feel a lack of engine power, detect abnormal noise, etc., take the following steps:

WARNING:

To avoid the danger of being scalded, never remove the radiator cap while the engine is still hot. When the radiator cap is removed, pressurized hot water will spurt out, possibly causing serious injury.

1. Move the vehicle safely off the road, apply the parking brake and move the gearshift lever to neutral (automatic transmission to "P").

Do not stop the engine.

2. Turn off the air conditioner switch. Open all the windows, move the heater or air conditioner temperature control to "maximum hot" and fan control to "high speed".
3. Get out of the vehicle. Look and listen for steam or coolant escaping from the radiator before opening the hood. Wait until no steam or coolant can be seen before proceeding.

TOW TRUCK TOWING

4. Open the engine hood.

WARNING:

If steam or water is coming from the engine, stand clear to prevent getting burned.

5. If engine overheating is caused by climbing a long hill on a hot day, run the engine at a fast idle (approximately 1,500 rpm) until the temperature gauge indication returns to normal.
6. Visually check drive belts for damage or looseness. Also check if the cooling fan is running. The radiator hoses and radiator should not leak water.

WARNING:

Be careful not to allow your hands, hair or clothing to come into contact with, or to get caught in, the running fan, belts, or motor fan.

The fan motor can start at any time when the coolant temperature is high.

If coolant is leaking, the cooling fan belt is missing or loose, or the cooling fan does not run, stop the engine.

7. After the engine cools down, check the coolant level in the reservoir tank with

the engine running. Add coolant to the reservoir tank if necessary. Have your vehicle repaired at the nearest NISSAN dealer.

When towing your vehicle, all State (Provincial in Canada) and local regulations for towing must be followed. Incorrect towing equipment could damage your vehicle. Towing instructions are available from your NISSAN dealer. Local service operators will generally be familiar with the applicable laws and procedures for towing. To assure proper towing and to prevent accidental damage to your vehicle, NISSAN recommends that you have a service operator tow your vehicle. It is advisable to have the service operator carefully read the following precautions.

CAUTION:

- **When towing, make sure that the transmission, axles, steering system and power train are in working condition. If any unit is damaged, a dolly must be used.**
- **When towing with the front wheels on the ground:**

Turn the ignition key to the "OFF" position and secure the steering wheel in a straight-ahead position with a rope or similar device. Never place the ignition key in the "LOCK" position. This will

result in damage to the steering lock mechanism.

Move the gearshift lever to the neutral ("N" position).

On automatic transmission models, push the shift lever release knob to move the shift lever to the neutral ("N" position).

- When towing with the rear wheels on the ground, release the parking brake.
- Attach safety chains for all towing.

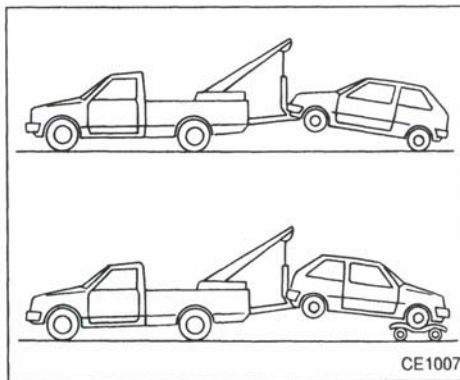

NISSAN recommends that your vehicle be towed with the driving (front) wheels off the ground as illustrated.

- **Speed: Below 70MPH (115 km/h)**
- **Distance: Less than 500 miles (800 km)**

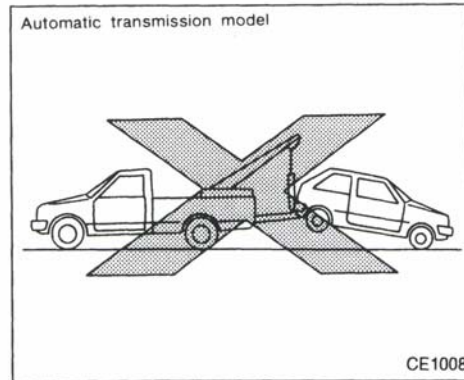

Towing an automatic transmission model with rear wheels raised (with front wheels on the ground)

CAUTION:

Never tow an automatic transmission model with the rear wheels raised (with the front wheels on the ground) as this may cause serious and expensive damage to the transmission. If it is necessary to tow the vehicle with the rear wheels raised, always use a towing dolly under the front wheels.

FREEING VEHICLE FROM SAND, SNOW OR MUD

If you have to tow an automatic transmission model with four wheels on ground

Observe the following restricted towing speeds and distances.

- **Speed: Below 30 MPH (50 km/h)**
- **Distance: Less than 40 miles (65 km)**

CAUTION:

Never tow an automatic transmission model from the rear (i.e., backward) with four wheels on the ground as this may cause serious and expensive damage to the transmission.

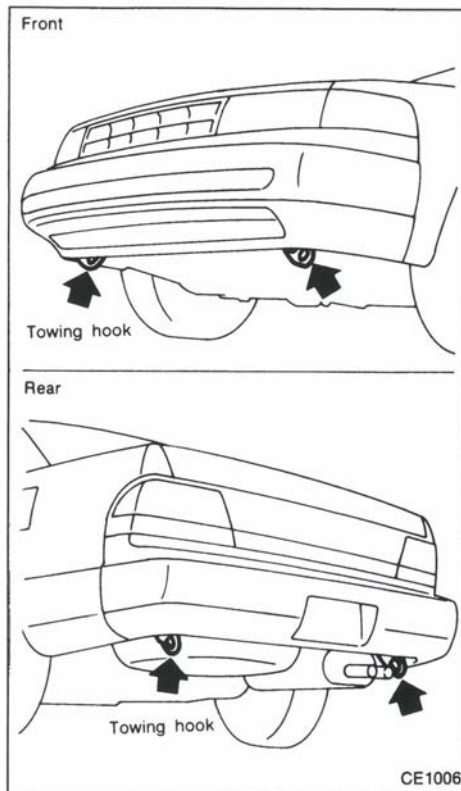

- Use the towing hooks **only**, not other parts of the vehicle. Otherwise, the vehicle body will be damaged.
- Use the towing hooks **only** to free a vehicle stuck in sand, snow, mud, etc. **Never** tow the vehicle using only the towing hooks.
- The towing hook is under tremendous force when used to free a stuck vehicle. Always pull the cable straight out from the front or rear of the vehicle. **Never** pull on the hook at a sideways angle.

6 Appearance and interior care

Cleaning exterior and interior	6-2
Corrosion protection	6-4



CLEANING EXTERIOR AND INTERIOR



Washing

Wash dirt off with a wet sponge and plenty of water. Clean the vehicle thoroughly using a mild soap or detergent (a special vehicle soap or general purpose dish-washing liquid) mixed with clean, lukewarm (never hot) water.

CAUTION:

Do not use strong household soap, strong chemical detergents, gasoline or solvents.

Rinse the vehicle thoroughly with plenty of clean water.

Inside flanges, seams and folds on the doors, hatches and hood are particularly vulnerable to the effects of road salt. Therefore, these areas must be regularly cleaned. Take care that the drain holes in the lower edge of the door are open. Spray water under the body and in the wheel wells to loosen the dirt and wash away road salt.

A damp chamois can be used to dry the vehicle to avoid water spots.

Waxing

Regular waxing protects the paint surface and helps retain new vehicle appearance. After waxing, polishing is recommended to remove built-up residue and to avoid a "weathered" appearance.

Removing spots

Remove tar and oil spots, industrial dust, insects, and tree sap as quickly as possible from the surface of the paint to avoid lasting damage or staining. Special cleaning products are available at your NISSAN dealer or any automotive accessory store.

Underbody

In areas where road salt is used in winter,

the underbody must be cleaned regularly. This will prevent dirt and salt from building up and causing underbody and suspension corrosion. Before the winter period and again in the spring, the underseal must be checked and, if necessary, re-treated.

High-mounted stop light removal

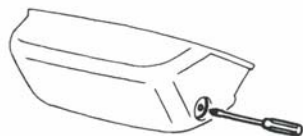

Push the center
to remove the
clip

AI1003M

Cleaning glass

Use glass cleaner to remove smoke and dust film from the glass surfaces. It is normal for glass to become coated with a film after the vehicle is parked in the hot sun. Glass cleaner and a soft cloth will easily remove this film.

CAUTION:

When cleaning the inside of the window, do not use sharp-edged tools, abrasive cleaners or chlorine based disinfectant cleaners. They could damage electrical conductors or rear window defogger elements.

Cleaning alloy wheels

Wash regularly, especially during winter months in areas where road salt is used. Salt could discolor the wheel if not removed.

Chrome parts

Clean all chrome parts regularly with a non-abrasive chrome polish to maintain the finish.

Plastic parts

Plastic parts can be cleaned with a mild soap solution. If the dirt cannot be easily removed, use a plastic cleaner. Do not use solvents.

Cleaning interior

Occasionally remove loose dust from the interior trim and seats using a vacuum cleaner or soft brush. Wipe the vinyl and leather surfaces with a clean, soft cloth dampened in mild soap solution, then wipe clean with a dry soft cloth. Before using any fabric protector, read the manufacturer's recommendations. Some fabric protectors contain chemicals that may stain or bleach the seat material.

CAUTION:

- **Never use benzine, thinner, or any similar material.**
- **The leather seats should be regularly coated with a leather wax like saddle soap. Never use car wax.**
- **Never use fabric protectors unless recommended by the manufacturer.**

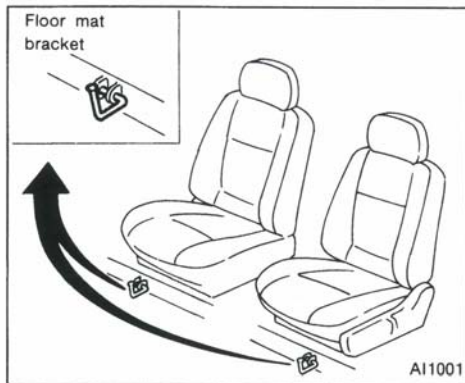

Floor mat positioning aid

Some MAXIMA models include a floor mat bracket to act as a floor mat positioning aid. For Nissan floor mats especially designed for your vehicle model that incorporate a grommet hole, simply position the mat using the floor mat bracket hook through the floor mat grommet hole while centering the mat in the floorpan contour. Repeat this procedure for both the driver side and front passenger side floor mats.

Periodically check to make certain that the mats are properly positioned.

Floor mats

The use of Genuine Nissan floor mats can extend the life of your vehicle carpet and make it easier to clean the interior. No matter what mats are used, be sure they are fitted for your vehicle and are properly positioned in the footwell to prevent interference with pedal operation. Mats should be maintained with regular cleaning and replaced if they become excessively worn.

Seat belts

The seat belts can be cleaned by wiping them with a sponge dampened in a mild soap solution. Allow the belts to dry completely before using them. Do not allow wet belts to roll up in the retractor. NEVER use bleach, dye, or chemical solvents since these may severely weaken the seat belt webbing.

CORROSION PROTECTION

Most common factors contributing to vehicle corrosion:

1. The accumulation of moisture-retaining dirt and debris in body panel sections, cavities, and other areas.
2. Damage to paint and other protective coatings caused by gravel and stone chips or minor traffic accidents.

Environmental factors influence the rate of corrosion:

Moisture

Accumulation of sand, dirt and water on the vehicle body underside can accelerate corrosion. Wet floor coverings will not dry completely inside the vehicle, and should be removed for drying to avoid floor panel corrosion.

Relative humidity

Corrosion will be accelerated in areas of high relative humidity, especially those areas where the temperatures stay above freezing and where atmospheric pollution exists and road salt is used.

Temperature

A temperature increase will accelerate the rate of corrosion to those parts which are not well ventilated.

Air pollution

Industrial pollution, the presence of salt in the air in coastal areas, or heavy road salt use will accelerate the corrosion process. Road salt will also accelerate the disintegration of paint surfaces.

To protect your vehicle from corrosion:

- Wash and wax your vehicle often to keep the vehicle clean.
- Always check for minor damage to the paint and repair it as soon as possible.
- Keep drain holes at the bottom of the doors open to avoid water accumulation.
- Check the underbody for accumulation of sand, dirt or salt. If present, wash with water as soon as possible.
- **NEVER remove dirt, sand or other debris from the passenger compartment by washing it out with a hose. Remove dirt with a vacuum cleaner or broom.**

- **Never allow water or other liquids to come in contact with electronic components inside the vehicle.**

MEMO

7 Do-it-yourself operations

Precautions.....	7-2
Engine cooling system.....	7-5
Engine oil.....	7-8
Automatic transmission fluid	7-11
Power steering fluid.....	7-12
Brake and clutch fluid	7-13
Window washer fluid.....	7-13
Battery.....	7-14
Drive belts	7-15
Spark plug replacement.....	7-15
Air cleaner filter	7-18
Wiper blades.....	7-18
Parking brake	7-19
Brake pedal	7-20
Brake booster	7-20
Clutch pedal.....	7-21
Fuses.....	7-21
Fusible links	7-22
Light bulbs	7-23
Wheels and tires	7-28



PRECAUTIONS

When performing any inspection or maintenance work on your vehicle, always take care to prevent serious accidental injury to yourself or damage to the vehicle. The following are general precautions which should be closely observed.

- **Park the vehicle on a level surface, apply the parking brake securely and block the wheels to prevent the vehicle from moving. Move the transmission control lever to neutral ("N").**
- **Do not work under the hood while the engine is hot. Turn off the engine and wait until it cools down.**
- **Be sure to turn the ignition key to the "OFF" or "LOCK" position.**

When the ignition key is in the "ON" or "ACC" position, the cooling fan may start to operate suddenly even when the engine is not running.

- **If you must work with the engine running, keep your hands, clothing, hair and tools away from moving fans, belts and any other moving parts.**
- **It is advisable to remove ties and any jewelry, such as rings, watches, etc.**

before working on your vehicle.

- **If you must run the engine in an enclosed space such as a garage, be sure there is proper ventilation for exhaust gases.**
- **Never get under the vehicle while it is supported only by a jack. If it is necessary to work under the vehicle, support it with safety stands.**
- **Keep smoking materials, flame and sparks away from fuel and battery.**
- **Never connect or disconnect either the battery or any transistorized component connector while the ignition is on.**
- **On gasoline engine models with the Multiport fuel injection system, the fuel filter or fuel lines should be serviced by a NISSAN dealer because the fuel lines are under high pressure even when the engine is off.**
- **Failure to follow these or other common sense guidelines may lead to serious injury or vehicle damage.**
- **Improperly disposed motor oil and/or other vehicle fluids can hurt the environment. Always conform to local regulations for disposal of vehicle fluid.**

This "Do-it-yourself operations" section gives instructions regarding only those items which are relatively easy for an owner to perform.

You should be aware that incomplete or improper servicing may result in operating difficulties or excessive emissions, and could affect your warranty coverage. **If in doubt about any servicing, have it done by your NISSAN dealer.**

CHECK LOCATIONS IN ENGINE COMPARTMENT

VG30E engine

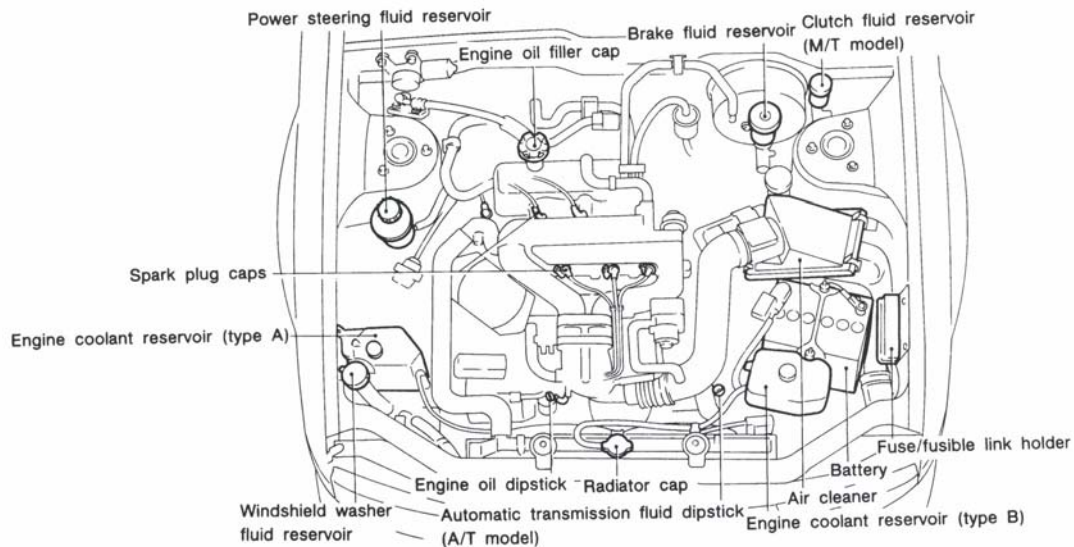

VE30DE engine

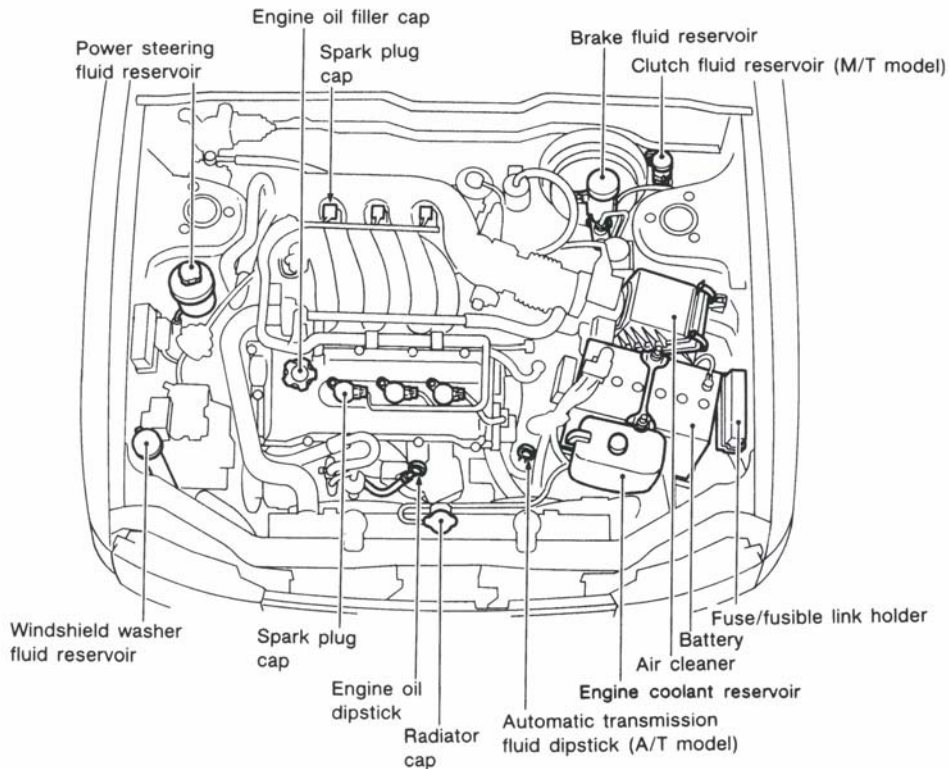

ENGINE COOLING SYSTEM

The engine cooling system is filled at the factory with a high-quality, year-round, anti-freeze coolant solution. The anti-freeze solution contains rust and corrosion inhibitors, therefore additional cooling system additives are not necessary.

CAUTION:

When adding or replacing coolant, be sure to use only an ethylene glycol anti-freeze with the proper mixture ratio. Examples are shown below:

Outside temperature down to		Anti-freeze	Soft water
°C	°F		
-15	5	30%	70%
-35	-30	50%	50%

The use of other types of coolant solutions may damage your cooling system.

The radiator is equipped with a pressure cap. Use a NISSAN genuine cap or its equivalent when replacement is required.

Never remove the radiator cap when the engine is hot. Serious burns could be caused by high pressure fluid escaping from the radiator.

Wait until the engine and radiator cool down. See precautions in "If Your Vehicle Overheats" found in the "In case of emergency" section.

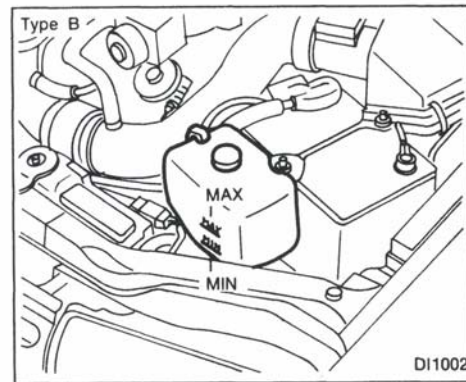
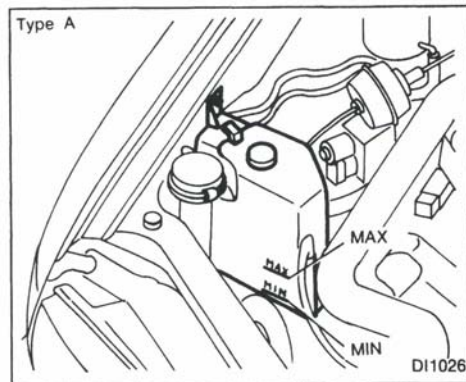

CHECKING ENGINE COOLANT LEVEL

With coolant reservoir

Check the coolant level in the reservoir tank when the engine is cold. If the coolant level is below "MIN", add coolant up to the "MAX" level. If the reservoir tank is empty, check the coolant level in the radiator **when the engine is cold**. If there is insufficient coolant in the radiator, fill the radiator with coolant up to the filler opening and also add it to the reservoir tank up to the "MAX" level.

If the cooling system frequently requires coolant, have it checked by your NISSAN dealer.

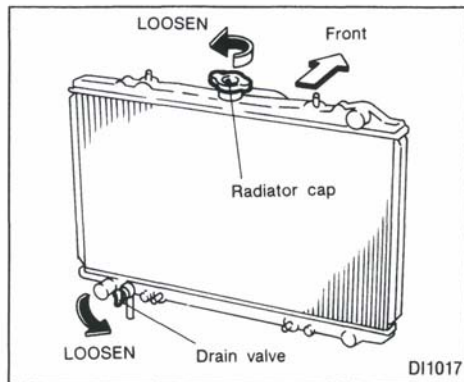

CHANGING ENGINE COOLANT

WARNING:

To avoid the danger of being scalded, never change the coolant when the engine is hot.

1. Move the heater or air conditioner temperature control to the maximum hot position.
2. Open the radiator cap and drain valve.
Open the drain plug on the engine block.
3. Open the air release plug to drain the coolant.

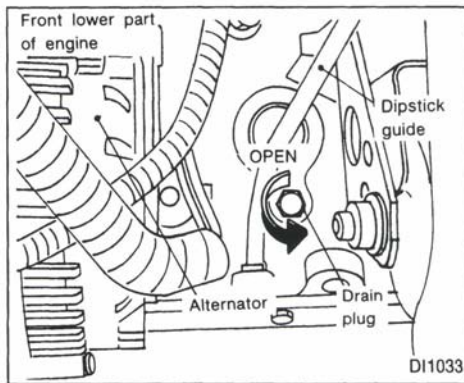

4. Flush the cooling system by running fresh water through the radiator.
5. Close the drain valve and drain plug securely.
6. See the "Technical information" section for cooling system capacity. Fill the radiator slowly with the proper mixture of coolant and water. Fill the reservoir tank up to the "MAX" level. Then install the radiator cap and close the air release plug.

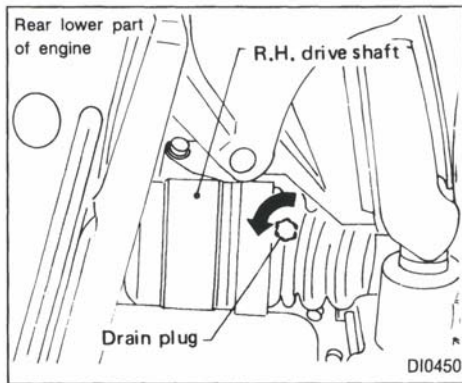

7. Start the engine, and warm it up until the radiator fan operates. Then race the engine 2 or 3 times under no load. Watch the coolant temperature gauge for signs of overheating.

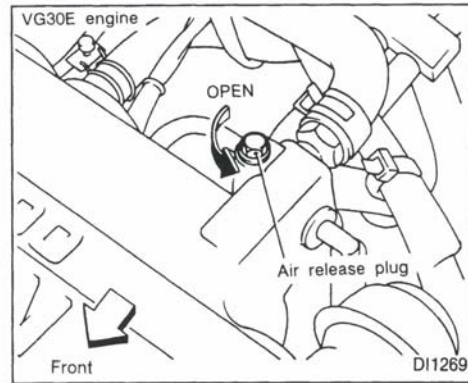

8. Stop the engine. After it completely cools down, refill the radiator up to the filler opening. Fill the reservoir tank up to the "MAX" level.
9. Check the drain valve and drain plug for any sign of leakage.

ENGINE OIL

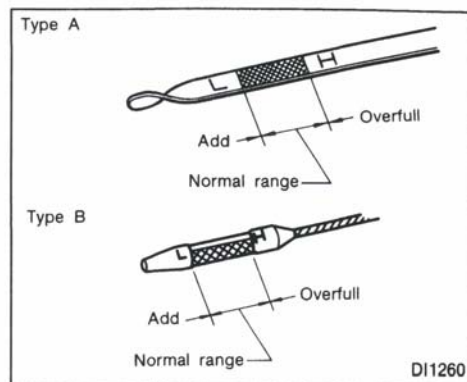
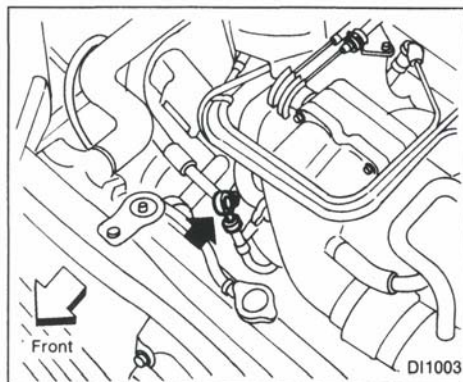
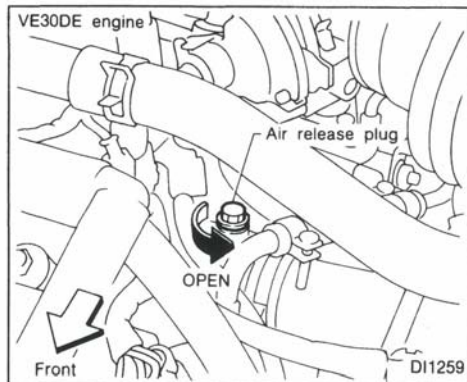

CHECKING ENGINE OIL LEVEL

1. Park the vehicle on a level surface and apply parking brake.
2. Run the engine until it reaches operating temperature.
3. Turn off the engine. **Wait a few minutes for the oil to drain back into the oil pan.**
4. Remove the dipstick and wipe it clean. Reinsert it all the way.

5. Remove the dipstick again and check the oil level. It should be between the "H" and "L" marks. If the oil level is below the "L" mark, remove the oil filler cap and pour recommended oil through the opening. **Do not overfill.**
6. Recheck oil level with dipstick.

CAUTION:

- **Oil level should be checked regularly. Operating with insufficient amount of oil can damage the engine, and such damage is not covered by warranty.**

- It is normal to add some oil between oil maintenance intervals or during the break-in period, depending on the severity of operating conditions.

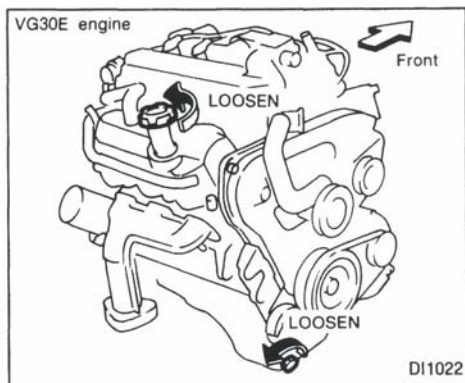

CHANGING ENGINE OIL

1. Park the vehicle on a level surface and apply the parking brake.
2. Run the engine until it reaches operating temperature, and then turn it off.
3. Place a large drain pan under the drain plug.
4. Remove the oil filler cap.

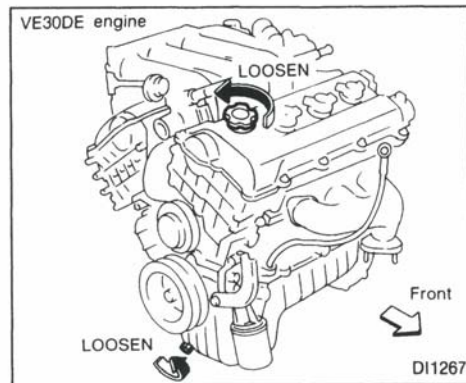

5. Remove the drain plug with a wrench and completely drain the oil.

If oil filter is to be changed, remove and replace it at this time. See "Changing oil filter".

WARNING:

Be careful not to burn yourself, as the engine oil is hot.

CAUTION:

Waste oil must be disposed of properly. Check your local regulations.

6. Clean and re-install the drain plug and washer. Securely tighten the drain plug with a wrench.

Drain plug tightening torque:

**22 to 29 ft-lb
(29 to 39 N·m)**

Do not use excessive force.

7. Refill engine with recommended oil and install the cap securely.

See the "Technical information" section for refill capacity.

8. Start the engine.

Check for leakage around the drain plug. Correct as required.

9. Turn the engine off and wait several minutes. Check the oil level with the dipstick. Add engine oil if necessary.

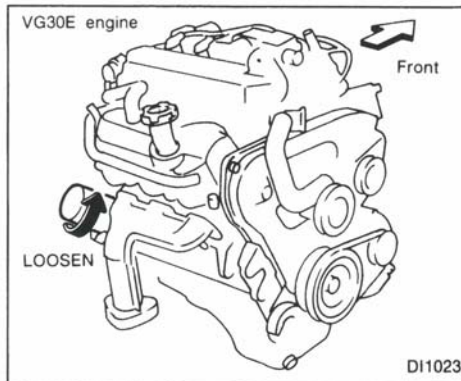

CHANGING OIL FILTER

1. Park the vehicle on a level surface and apply the parking brake.
2. Turn the engine off.
3. Loosen the oil filter with an oil filter wrench. (Depending on the engine model, a special **cap type** wrench may be required. See your NISSAN dealer if in doubt.) Remove the oil filter by turning it by hand.

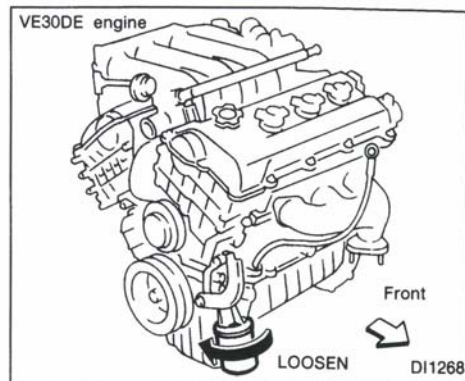

WARNING:

Be careful not to burn yourself, as the engine oil may be hot.

4. Wipe the engine oil filter mounting surface with a clean rag.

Be sure to remove any old rubber gasket remaining on the mounting surface of the engine.

5. Coat the rubber gasket on the new filter with clean engine oil.

AUTOMATIC TRANSMISSION FLUID

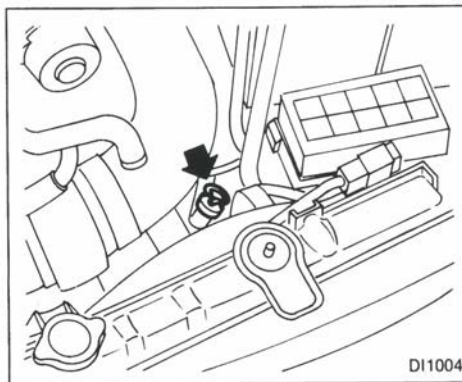

6. Screw in the oil filter until a slight resistance is felt, then tighten additionally more than 2/3 turn.
7. Start the engine and check for leakage around the oil filter. Correct as required.
8. Turn the engine off and wait several minutes. Check the oil level. Add engine oil if necessary.

WARNING:

When engine is running, keep hands and clothing away from any moving parts such as fan drive belt.

TEMPERATURE CONDITIONS FOR CHECKING

- The fluid level should be checked using the "HOT" range on the dipstick after the following conditions have been met:
 - The engine should be warmed up to operating temperature.

- The vehicle should be driven at least 5 minutes.
 - The automatic transmission fluid should be warmed to between 122 and 176°F (50 and 80°C).
 - The fluid can be checked at fluid temperatures of 86 to 122°F (30 to 50°C) using the "COLD" range on the dipstick after the engine is warmed up and before driving. However, the fluid should be re-checked using the "HOT" range.
1. Park the vehicle on a level surface and set the parking brake.
 2. Start the engine and then move the selector lever through each gear range ending in "P".

POWER STEERING FLUID

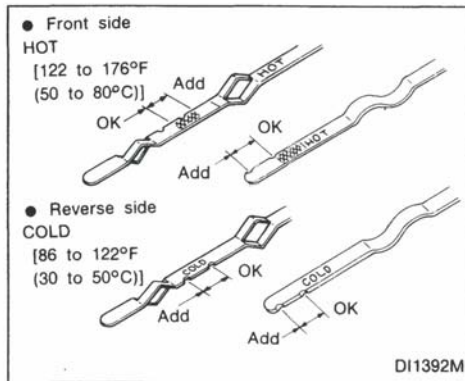

3. Check the fluid level with the engine idling.
4. Remove the dipstick and wipe it clean with lint-free paper.
5. Reinsert the dipstick into the charging pipe as far as it will go.
6. Remove the dipstick and note the reading. If the level is at the low side of either range, add fluid to the charging pipe.

DO NOT OVERFILL.

USE ONLY DEXRON™II-E TYPE FLUID.

NOTE:

If the vehicle has been driven for a long time at high speeds, or in city traffic in hot weather, or if it is being used to pull a trailer, the accurate fluid level cannot be read. You should wait until the fluid has cooled down (about 30 minutes).

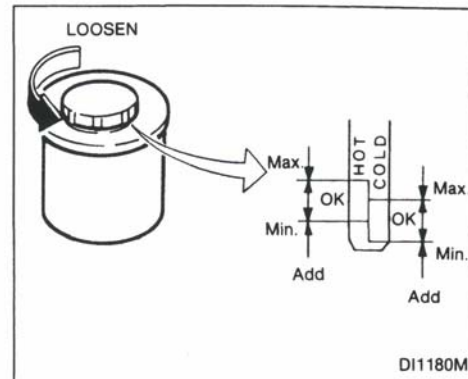

Check the fluid level.

The fluid level should be checked using the "HOT" range on the dipstick at fluid temperatures of 122 to 176°F (50 to 80°C) or using the "COLD" range on the dipstick at fluid temperatures of 32 to 86°F (0 to 30°C).

CAUTION:

- Do not overfill.
- The recommended fluid is Type DEXRON™II or equivalent.

BRAKE AND CLUTCH FLUID

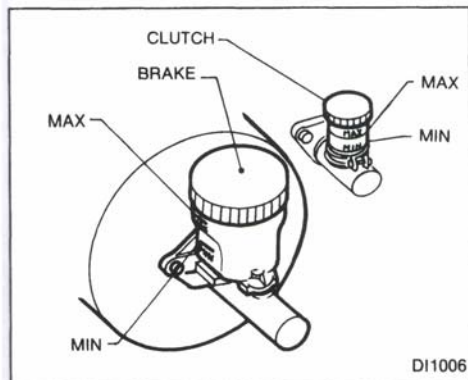

Check the fluid level in the reservoir. If the fluid is below the Min. line or the brake warning light comes on, add **DOT 3** fluid up to the Max. line. If fluid must be added frequently, the system should be thoroughly checked by your NISSAN dealer.

CAUTION:

- Use only new fluid. Old, inferior, or contaminated fluid may damage the brake and clutch systems. The use of improper fluids can damage the brake system and affect the vehicle's stopping ability.

WINDOW WASHER FLUID

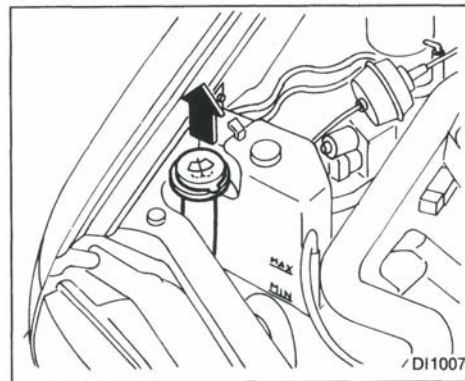

Add fluid when the low washer fluid warning light comes on. Add a washer solvent to the water for better cleaning. In the winter season, add a windshield washer anti-freeze. Follow the manufacturer's instructions for the mixture ratio.

CAUTION:

- Do not substitute engine anti-freeze coolant for window washer solution. This may result in damage to the paint.

BATTERY

- Keep the battery surface clean and dry. Any corrosion should be washed off with a solution of baking soda and water.
- Make certain the terminal connections are clean and securely tightened.
- If the vehicle is not to be used for 30 days or longer, disconnect the "—" negative battery terminal cable to prevent discharge.

WARNING:

Do not expose the battery to flames or electrical sparks. Hydrogen gas generated by battery action is explosive. Do not allow battery fluid to contact your skin, eyes, fabrics, or painted surfaces. After touching a battery or battery cap, do not touch or rub your eyes. Thoroughly wash your hands. If the acid contacts your eyes, skin or clothing, immediately flush with water for at least 15 minutes and seek medical attention.

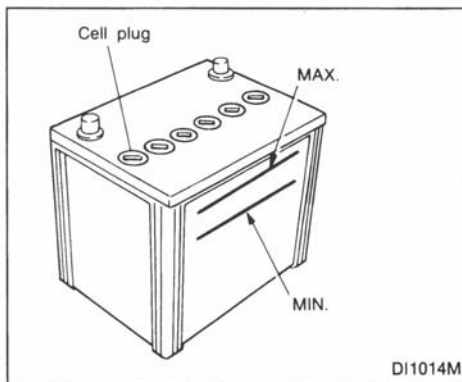

JUMP STARTING

If jump starting is necessary, see the "In case of emergency" section. If the engine does not start by jump starting, the battery may have to be replaced. Contact your NISSAN dealer.

Check the fluid level in each cell. It should be between the MAX. and MIN. lines.

If it is necessary to add fluid, add only distilled water to bring the level to the indicator in each filler opening. **Do not overfill.**

1. Remove the cell plugs using a suitable tool.
2. Add distilled water up to the MAX. level.
3. Tighten cell plugs.

DRIVE BELTS

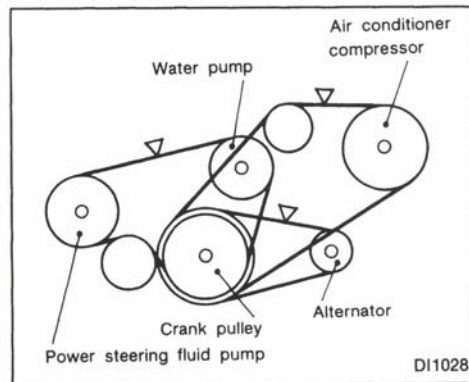

WARNING:

Be sure the ignition key is "OFF".

1. Visually inspect each belt for signs of unusual wear, cuts, fraying or looseness. If the belt is in poor condition or loose, have it replaced or adjusted by your NISSAN dealer.
2. Have the belts checked regularly for condition and tension in accordance with the maintenance schedule in this manual.

SPARK PLUG REPLACEMENT

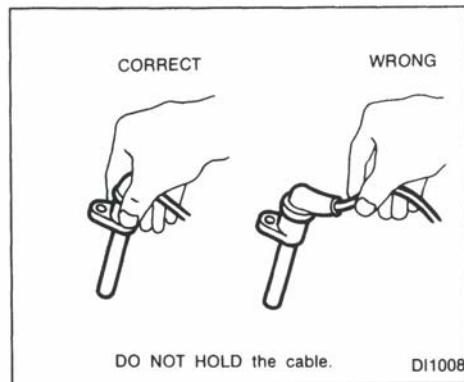

WARNING:

Be sure the engine and ignition switch are off and that the parking brake is engaged securely.

CAUTION:

Be sure to use the correct wrench to remove the plugs. An incorrect wrench can cause damage.

VG30E engine models

1. Remove brackets as necessary to give access to the high tension cables and spark plugs.
2. Disconnect the spark plug cables from the spark plugs.

When disconnecting, always hold the boots, not the cables. Mark all cables to identify their original locations.

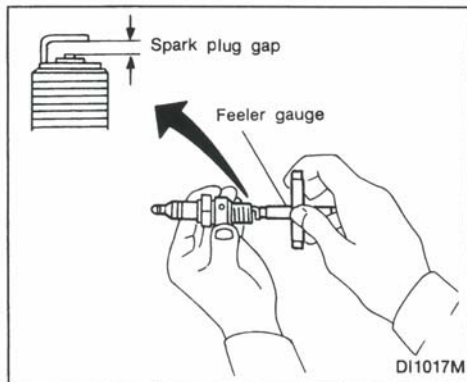

- Remove the spark plugs with a spark plug wrench.

The plug wrench has a rubber seal that holds the spark plug so that it will not fall when it is pulled out. Make sure that each spark plug is snugly fitted into the plug wrench.

- Check the gap on each new spark plug with a feeler gauge. (The spark plug gap is shown in the "Technical information" section.) Adjust it as required.

- Fit the new plugs, one at a time, into the spark plug wrench and install them. Turn each plug in several full turns by hand, then tighten with a spark plug wrench to the correct torque. Do not overtighten.

Spark plug tightening torque:

**14 to 22 ft-lb
(20 to 29 N·m)**

- Holding the boot, re-connect each high tension cable to its proper spark plug by pushing it on until you feel a snap.
- Re-install all brackets as necessary.

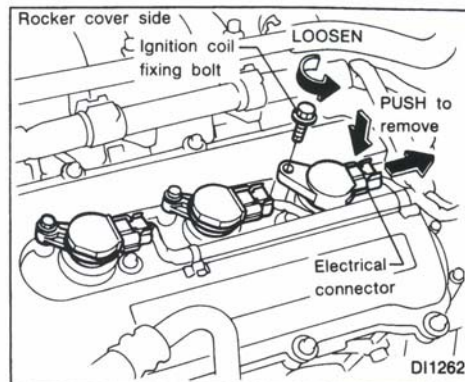

VE30DE engine models

- Disconnect the electrical connectors.
- Loosen the ignition coil fixing bolts. And remove the ignition coil to give access to the spark plugs.
- Remove the spark plugs with a spark plug wrench.

The plug wrench has a rubber seal that holds the spark plug so that it will not fall when it is pulled out. Make sure that each spark plug is snugly fitted into the plug wrench.

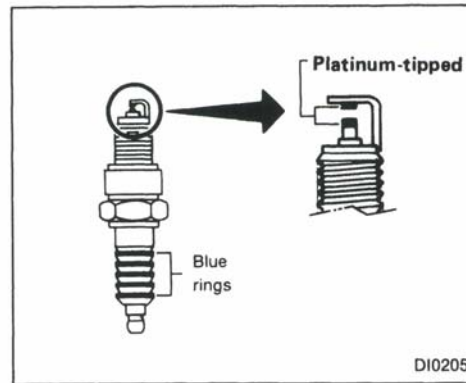
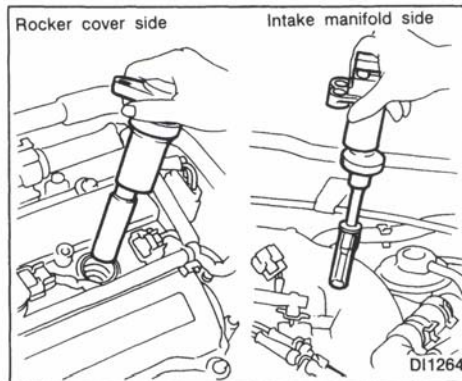
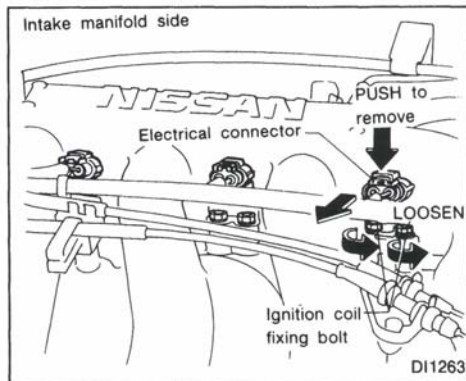

4. Fit the new plugs, one at a time, into the spark plug wrench and install them. Turn each plug in several full turns by hand, then tighten with a spark plug wrench to the correct torque. Do not overtighten.

Spark plug tightening torque:

**14 to 22 ft-lb
(20 to 29 N-m)**

5. Holding the ignition coil, re-connect each ignition coil to its proper spark plug by pushing it on until you feel a snap.
6. Tighten all ignition coils.

Platinum-tipped spark plug

It is not necessary to replace the platinum-tipped spark plugs as frequently as the conventional type spark plugs since they will last much longer. Follow the maintenance schedule but, do not reuse them by cleaning or regapping. Blue rings on the ceramic portion indicate that the plugs are platinum-tipped type.

Always replace with recommended platinum-tipped spark plugs.

AIR CLEANER FILTER

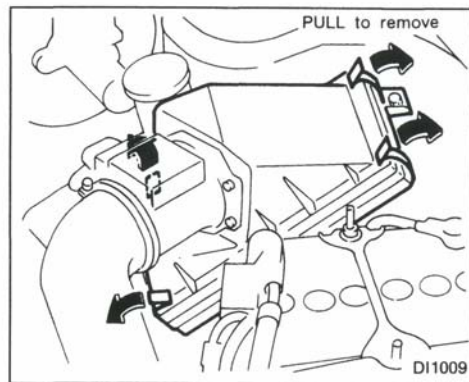

Viscous paper type

The filter element should not be cleaned and reused. Replace it according to the maintenance intervals shown in the "Maintenance schedule" section. When replacing the filter, wipe the inside of the air cleaner housing and the cover with a damp cloth.

WIPER BLADES

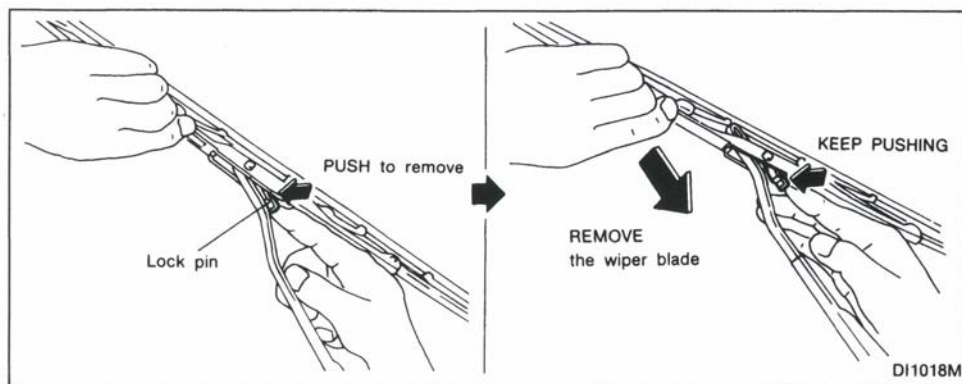

1) CLEANING

If your windshield is not clear after using the windshield washer or if the wiper blade chatters when running, wax or other material may be on the blade or windshield.

Clean the outside of the windshield with a washer solution or a mild detergent. Your windshield is clean if beads do not form when rinsing with clear water.

Clean the blade by wiping it with a cloth soaked in a washer solution or a mild detergent. Then rinse the blade with

clear water. If your windshield is still not clear after cleaning the blades and using the wiper, replace the blades.

2) REPLACEMENT

1. Pull the wiper arm.
2. Push the lock pin, then remove the wiper blade.
3. Insert the new wiper blade to the wiper arm until a click sounds.

PARKING BRAKE

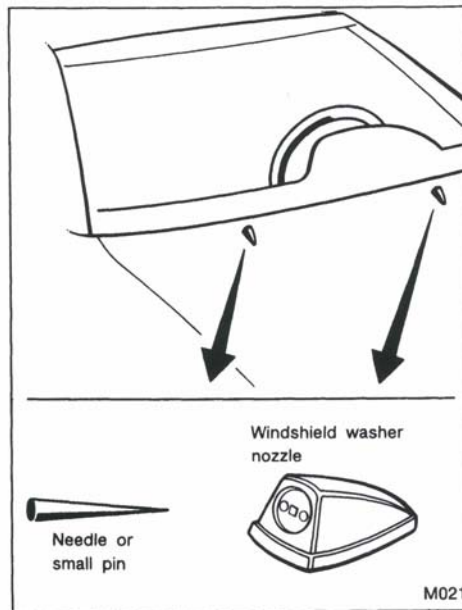

CAUTION:

Make sure the wiper blade contacts the glass, otherwise the arm may be damaged from wind pressure.

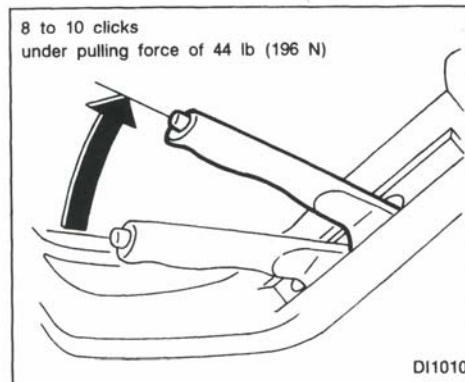

From the released position, pull the parking brake lever up slowly and firmly. If the number of clicks is out of the range listed above, see your NISSAN dealer.

If you wax the surface of the hood, be careful not to let wax get into the washer nozzle. This may cause clogging or improper windshield washer operation. If wax gets into the nozzle, remove it with a needle or small pin.

BRAKE PEDAL

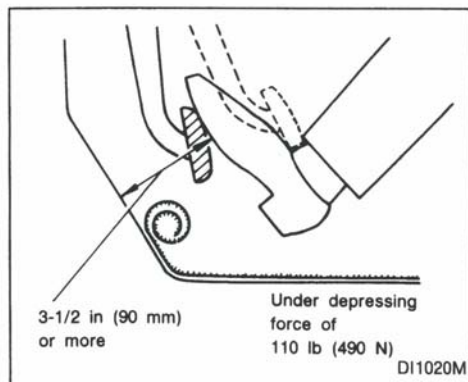

With the engine running, check the distance between the upper surface of the pedal and the metal floor. If it is out of the range shown above, see your NISSAN dealer.

Self-adjusting brakes

Your vehicle is equipped with self-adjusting brakes.

The front disc-type brakes self-adjust every time the brake pedal is applied. The rear drum-type brakes self-adjust every time the parking brake is applied. If the brake pedal goes down farther than normal, it may be due to a lack of adjustment of the rear drum brakes. Apply the parking brake several times.

WARNING:

See your NISSAN dealer and have it checked if the brake pedal height does not return to normal.

BRAKE BOOSTER

Check the brake booster function as follows:

1. With the engine off, depress the brake pedal several times to make sure that the pedal travel distance does not change.
2. While depressing the brake pedal, start the engine. The pedal height should drop a little.
3. With the brake pedal depressed, stop the engine. Keeping the pedal depressed for about 30 seconds, the pedal height should not change.
4. Run the engine for one minute without depressing the brake pedal, then turn it off. Depress the brake pedal several times. The pedal travel distance will decrease gradually with each depression as the vacuum is released from the booster.

If the brakes do not operate properly, see your NISSAN dealer.

CLUTCH PEDAL

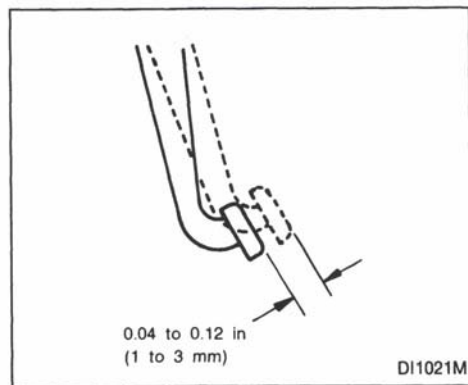

Press the pedal by hand and be sure the free travel is within the limits shown above. If free travel is too little or too much, see your NISSAN dealer.

FUSES

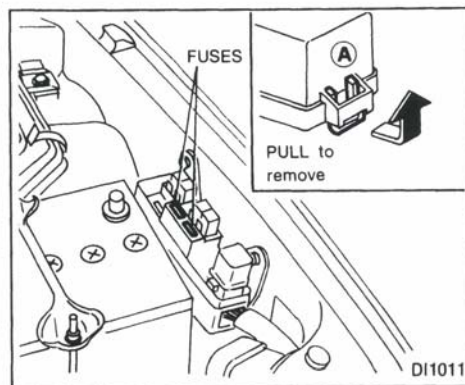

Engine compartment (Headlight fuses)

If the headlight does not come on, check for a burned-out fuse.

1. Be sure the ignition key and headlight switch are "OFF".
2. Open the engine hood.
3. Remove the fusible link cover (A).
4. Remove the fuse with the fuse puller.
5. If the fuse is burned out, replace it with a new fuse.

Never use a fuse of higher amperage rating than that specified on the fuse box cover.

6. If a new fuse burns out again, have the electrical system checked and repaired by your NISSAN dealer.

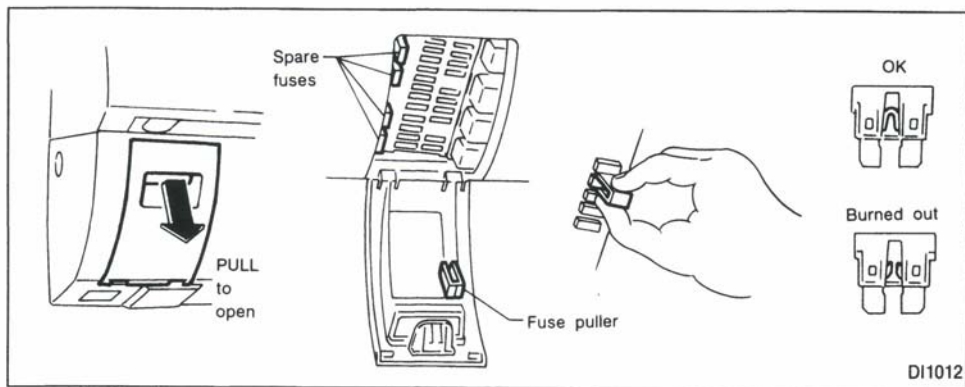

Passenger compartment

If the electrical equipment does not operate, check for a burned-out fuse.

1. Be sure the ignition key and headlight switch are "OFF".
2. Open the fuse box lid.
3. Remove the fuse with the fuse puller.
4. If the fuse is burned, replace it with a new fuse.

Never use a fuse of higher amperage rating than that specified on the fuse box cover.

5. If a new fuse burns again, have the electrical system checked and repaired by your NISSAN dealer.

FUSIBLE LINKS

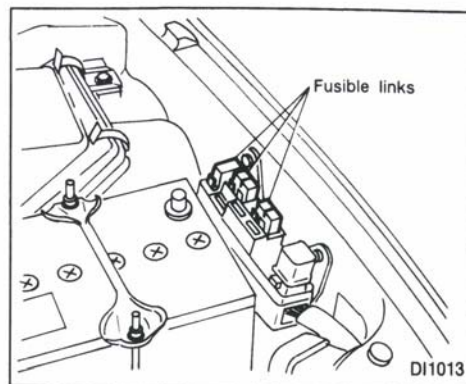

If the electrical equipment does not operate and fuses are in good condition, check the fusible links. If any of these fusible links are melted, replace only with genuine NISSAN parts.

LIGHT BULBS

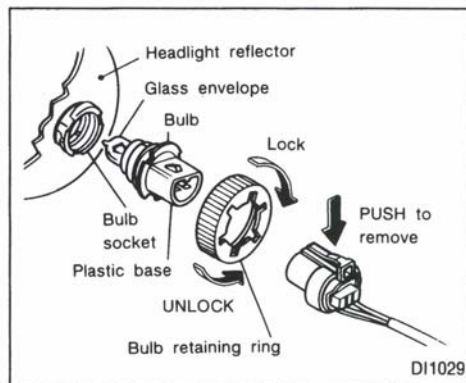

HEADLIGHTS

The headlight is a semi-sealed beam type which uses a replaceable headlight (halogen) bulb. A bulb can be replaced from inside the engine compartment without removing the headlight assembly.

CAUTION:

High pressure halogen gas is sealed inside the halogen bulb. The bulb may break if the glass envelope is scratched or the bulb is dropped.

Hold the plastic base when handling the

bulb. **Never touch the glass envelope.**

Removing the headlight bulb

1. Disconnect the battery negative cable.
2. Disconnect the electrical connector from the rear end of the bulb.
3. Turn the bulb retaining ring counter-clockwise until it is free from the headlight reflector, then remove it.
4. Remove the headlight bulb. Do not shake or rotate the bulb when removing it.

Replacing the headlight bulb

1. Insert the bulb into the headlight reflector with the flat side of the plastic base facing upward.
2. Install the bulb retaining ring and turn it clockwise until it stops.
3. Push the electrical connector into the bulb plastic base until it snaps and stops.

CAUTION:

DO NOT TOUCH THE BULB.

- Use the same number and wattage as originally installed:

Wattage 65/45

Bulb no. 9004

- Aiming is not necessary after replacing the bulb. When aiming adjustment is necessary, contact your NISSAN dealer.
- Do not leave the bulb out of the headlight reflector for a long period of time as dust, moisture, and smoke may enter the headlight body and affect the performance of the headlight.

OTHER LIGHTS

Item	Wattage (W)	Bulb No.
Cornering/Front clearance	27/8	1157
Front turn signal light	27	1156 NA
Front side marker light	3.8	194
Rear combination light		
Turn signal	27	1156
Stop/Tail	27/8	1157
Back-up	27	1156
Rear side marker light	3.8	194
License plate light	7.5 or 8	89 (7.5W) or 67 (8W)
High-mounted stop light	18	921
Interior light	10	
Front personal light	10	
Step light	3.4	158
Trunk light	3.4	158

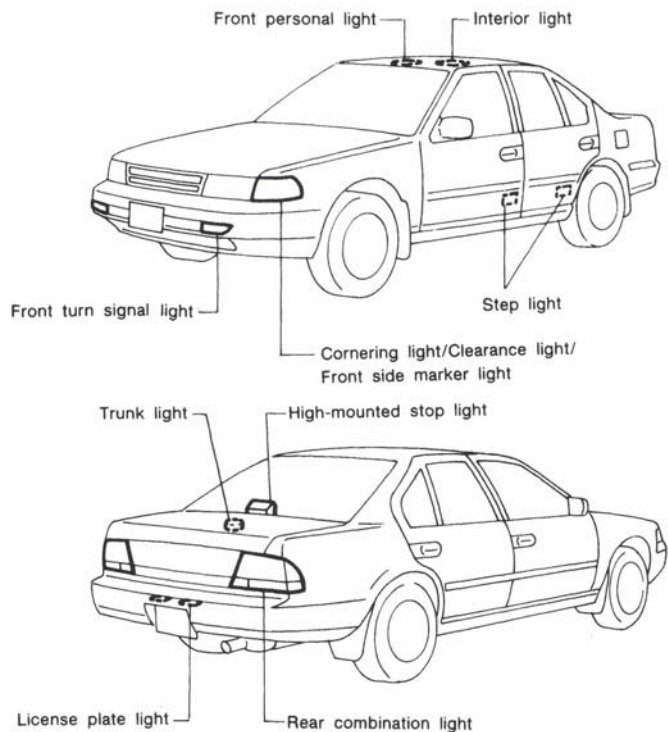

DI1014

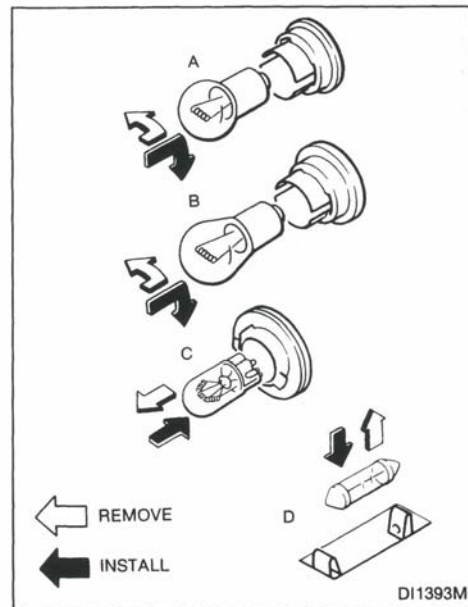

Replacement procedures

All other lights are either type A, B, C or D. When replacing a bulb, first remove the lens and/or cover.

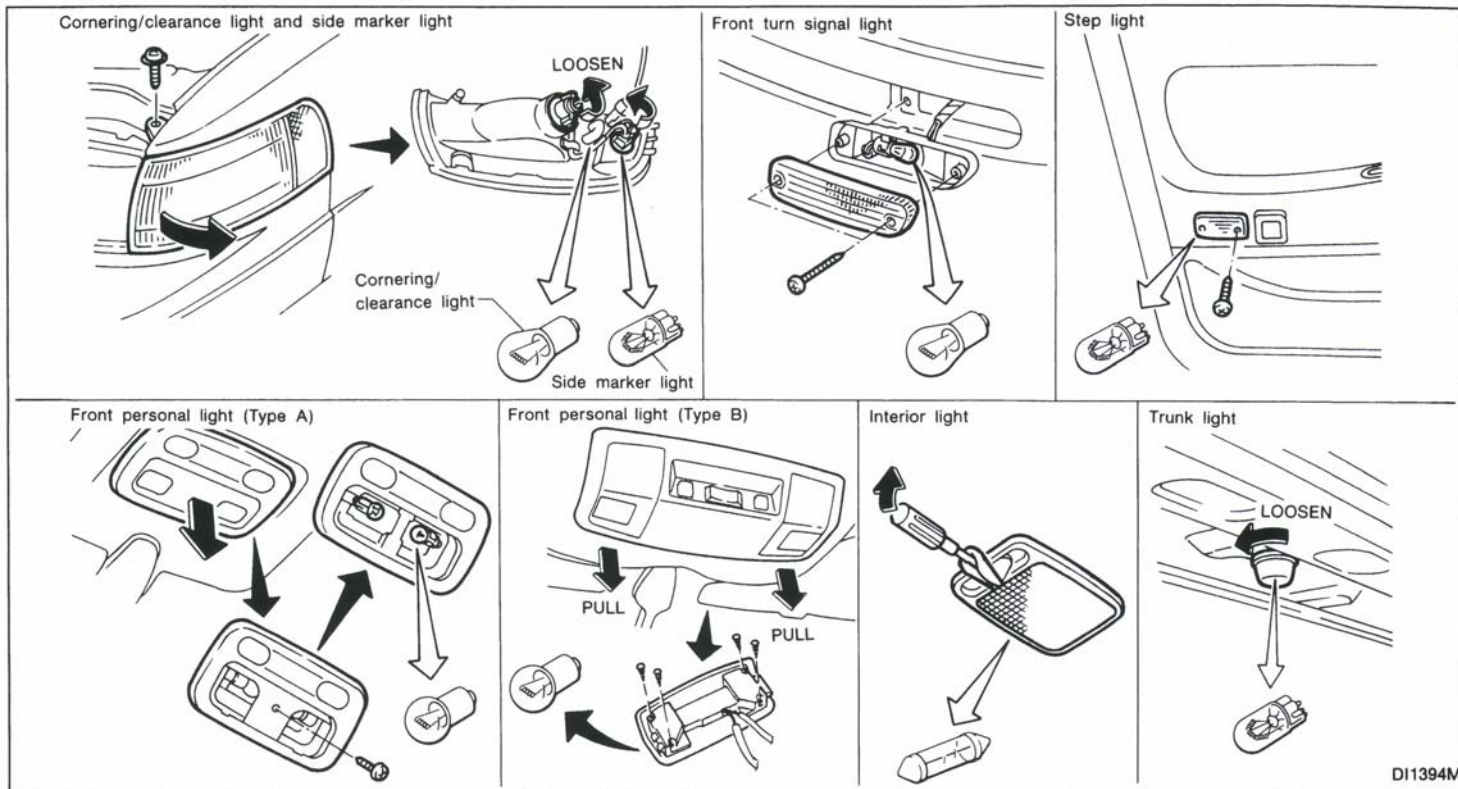

D11394M

Rear combination light

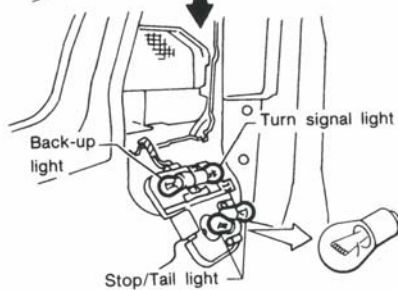
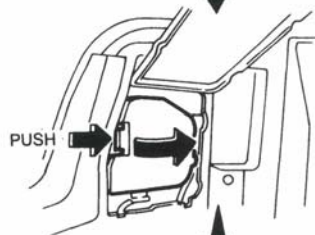
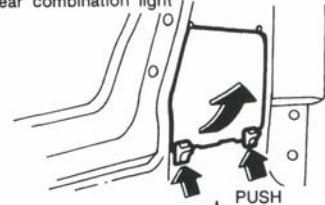

Rear side marker light

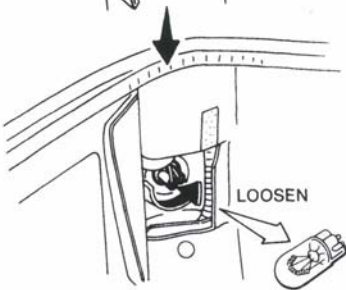
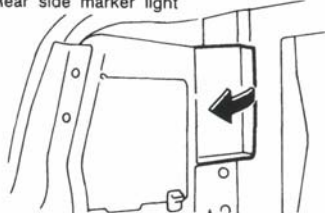

License plate light

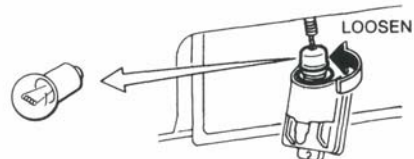
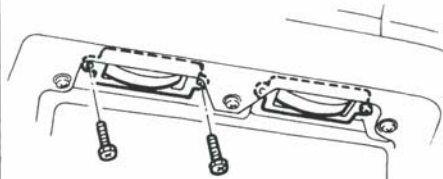

DI1395M

WHEELS AND TIRES

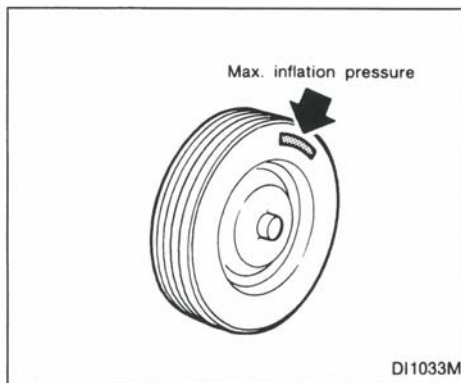
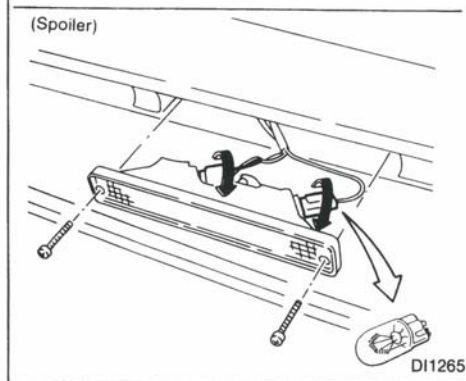
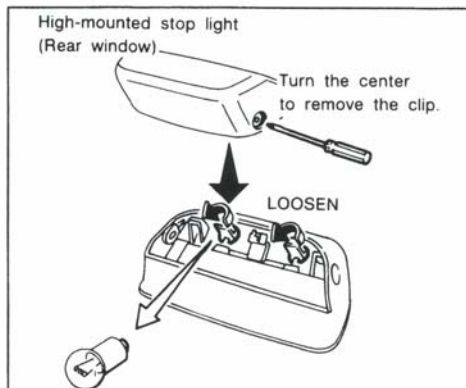

If you have a flat tire, see "In case of emergency" section.

Maximum inflation pressure

Do not exceed the maximum inflation pressures shown on the side wall of the tire.

Tire inflation pressure

Periodically check the tire pressure (including spare). Incorrect tire pressure may adversely affect tire life and vehicle handling. Tire pressure should be checked when tires are COLD. Tires are considered COLD after the vehicle has been parked for three or

more hours, or driven less than 1 mile (1.6 km). COLD tire pressures are shown on the tire placard affixed to the center console lid.

CAUTION:

The vehicle capacity weight is indicated on the tire placard. Do not load your vehicle beyond this capacity. Overloading your vehicle may result in reduced tire life, unsafe operating conditions due to premature tire failure, or unfavorable handling characteristics and could also lead to a serious accident. Loading beyond the specified capacity may also result in failure of other vehicle components.

Before taking a long trip, or whenever you have loaded your vehicle heavily, use a tire pressure gauge to ensure that the tire pressure is at the specified level.

Do not drive your vehicle over 85 MPH (140 km/h) unless it is equipped with high speed capability tires. Driving faster than 85 MPH (140 km/h) may result in tire failure, loss of control and possible injury.

Types of tires

CAUTION:

When changing or replacing tires, be sure

all four tires are of the same type (i.e., Summer, All Season or Snow) and construction. Your NISSAN dealer may be able to help you with information about tire type, size, speed rating and availability. Replacement tires may have a lower speed rating than the factory equipped tires, and may not match the potential maximum vehicle speed. Never exceed the maximum speed rating of the tire.

All season tires

NISSAN specifies All Season tires on some models to provide good performance for use all year around, including snowy and icy road conditions. All Season Tires are identified by "ALL SEASON" and/or "M&S" on the tire sidewall. Snow tires have better snow traction than All Season tires and may be more appropriate in some areas.

Summer tires

NISSAN specifies summer tires on some models to provide superior performance on dry roads. Summer tire performance in snow and ice will be substantially reduced. Summer tires do not have the tire traction rating "M&S" on the tire sidewall.

If you plan to operate your vehicle in snowy

or icy conditions, NISSAN recommends the use of "SNOW" or "ALL SEASON" tires on all four wheels.

Snow tires

If snow tires are needed, it is necessary to select tires equivalent in size and load rating to the original equipment tires. If you do not, it can adversely affect the safety and handling of your vehicle.

Generally, snow tires will have lower speed ratings than factory equipped tires and may not match the potential maximum vehicle speed. Never exceed the maximum speed rating of the tire.

For additional traction on icy roads, studded tires may be used. However, some provinces and states prohibit their use. Check local, state and provincial laws before installing studded tires. Skid and traction capabilities of studded snow tires, on wet or dry surfaces, may be poorer than that of non-studded snow tires.

Tire chains

Use of tire chains may be prohibited according to location. Check the local laws before installing tire chains. When install-

ing tire chains, make sure they are of proper size for the tires on your vehicle and are installed according to the chain manufacturer's suggestions. Use chain tensioners when recommended by the tire chain manufacturer to ensure a tight fit. Loose end links of the tire chain must be secured or removed to prevent the possibility of whipping action damage to the fenders or undercarriage. In addition, drive at a reduced speed. Otherwise, your vehicle may be damaged and/or vehicle handling and performance may be adversely affected.

Never install tire chains on a T-type spare tire.

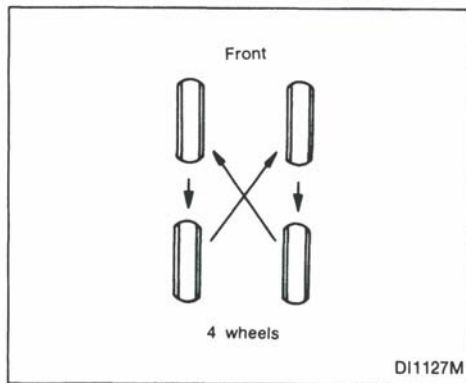

Tire rotation

NISSAN recommends that tires be rotated every 7,500 miles (12,000 km).

See "Flat tire" in the "In case of emergency" section for tire replacing procedures.

CAUTION:

- After rotating the tires, adjust the tire pressure.

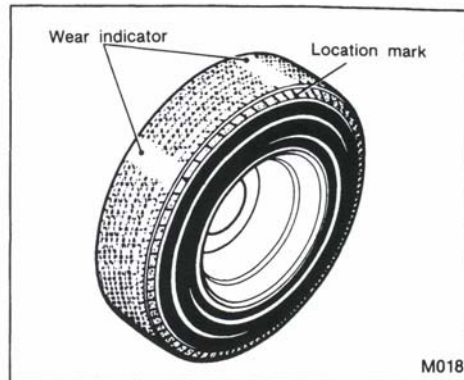

Tire wear and damage

CAUTION:

Tires should be periodically inspected for wear, cracking, bulging, or objects caught in the tread. If excessive wear, cracks, bulging, or deep cuts are found, the tire should be replaced.

The original tires have a built-in tread wear indicator. When the wear indicator is visible, the tire should be replaced.

Improper service for a T-type spare tire may result in serious personal injury. If it is

- Retighten the wheel nuts after the aluminum wheels have been run for the first 600 miles (1,000 km) (also in cases of a flat tire, etc.).
- Do not include the T-type spare tire or any other small size spare tire in the tire rotation.

necessary to repair the T-type spare tire, contact your NISSAN dealer.

Changing tires and wheels

When replacing a tire, use the same size, speed rating and load carrying capacity as originally equipped. Recommended types and sizes are shown in "Wheels and tires" in the "Technical information" section. The use of tires other than those recommended or the mixed use of tires of different brands, construction (bias, bias-belted or radial), or tread patterns can adversely affect the ride, braking, handling, ground clearance, body-to-tire clearance, snow chain clearance, speedometer calibration, headlight aim and bumper height. **Some of these effects may lead to accidents and could result in serious personal injury.**

If the wheels are changed for any reason, always replace with wheels which have the same offset dimension. Wheels of a different offset could cause early tire wear, possibly degraded vehicle handling characteristics and/or interference with the brake discs/drums. Such interference can lead to decreased braking efficiency and/or early brake pad/shoe wear.

WARNING:

Do not install a deformed wheel or tire even if it has been repaired. Such wheels or tires could have structural damage and could fail without warning.

Wheel balance

Unbalanced wheels may affect vehicle handling and tire life. Even with regular use, wheels can get out of balance. Therefore, they should be balanced as required.

Wheel balance service should be performed with the wheels off the vehicle. Spin balancing the front wheels on the vehicle could lead to transmission damage.

Care of wheels

- Wash the wheels when washing the vehicle to maintain their appearance.
- Clean the inner side of the wheels when the wheel is changed or the underside of the vehicle is washed.
- Do not use abrasive cleaners when washing the wheels.
- Inspect wheel rims regularly for dents or corrosion. Such damage may cause loss of pressure or poor seal at the tire bead.

- NISSAN recommends that the road wheels be waxed to protect against road salt in areas where it is used during winter.

Spare tire (T-type spare tire)

Observe the following precautions if the T-type spare tire must be used, otherwise your vehicle could be damaged or involved in an accident.

CAUTION:

- **The T-type spare tire should be used only for emergency. It should be replaced by the standard tire at the first opportunity.**
- **Drive carefully while the T-type spare tire is installed.**
Avoid sharp turns and abrupt braking while driving.
- **Periodically check tire inflation pressure, and always keep it at 60 psi (420 kPa, 4.2 bar).**
- **Do not drive your vehicle at speeds faster than 50 MPH (80 km/h).**
- **Do not use tire chains on a T-type spare tire. Tire chains will not fit properly on**

the T-type spare tire and may cause damage to the vehicle.

- When driving on roads covered with snow or ice, the T-type spare tire should be used on the rear wheel and the original tire used on the front wheels (drive wheels). Use tire chains only on the front two original tires.
- Tire tread of the T-type spare tire will wear at a faster rate than the original tire. Replace the T-type spare tire as soon as the tread wear indicators appear.
- Because the T-type spare tire is smaller than the original tire, ground clearance is reduced. To avoid damage to the vehicle do not drive over obstacles. Also do not drive the vehicle through an automatic car wash since it may get caught.
- Do not use the T-type spare tire on other vehicles.
- Do not use more than one T-type spare tire at the same time.

MEMO

MEMO

8 Maintenance schedule

General maintenance.....	8-3
Periodic maintenance	8-5



Your new NISSAN has been designed to have minimum maintenance requirements with longer service intervals to save you both time and money. However, some day-to-day and regular maintenance is essential to maintain your NISSAN's good mechanical condition, as well as its emission and engine performance.

It is the owner's responsibility to make sure that the specified maintenance, as well as general maintenance, is performed.

As the vehicle owner, you are the only one who can ensure that your vehicle receives the proper maintenance care. You are a vital link in the maintenance chain.

General maintenance

General maintenance includes those items which should be checked during normal day-to-day operation of the vehicle. They are essential if your vehicle is to continue to operate properly. It is your responsibility to perform these procedures regularly as prescribed.

These checks or inspections can be done by yourself, a qualified technician or, if you prefer, your NISSAN dealer.

Periodic maintenance

The maintenance items listed in this part are required to be serviced at regular intervals.

However, under severe driving conditions, additional or more frequent maintenance will be required.

Where to go for service

If maintenance service is required or your vehicle appears to malfunction, have the systems checked and tuned by an authorized NISSAN dealer.

NISSAN technicians are well-trained specialists and are kept up to date with the latest service information through technical bulletins, service tips, and in-dealership training programs. They are completely qualified to work on NISSAN's vehicles **before** they work on your vehicle, rather than after they have worked on it.

You can be confident that your NISSAN dealer's service department performs the best job to meet the maintenance requirements on your vehicle — in a reliable and economic way.

GENERAL MAINTENANCE

During the normal day-to-day operation of the vehicle, general maintenance should be performed regularly as prescribed in this section. If you detect any unusual sounds, vibrations or smell, be sure to check for the cause or have your NISSAN dealer do it promptly. In addition, you should notify your NISSAN dealer if you think that repairs are required.

When performing any checks or maintenance work, closely observe the precautions in the "Do-it-yourself operations" section.

Additional information on the following items with "" is found in the "Do-it-yourself operations" section.

OUTSIDE THE VEHICLE

The maintenance items listed here should be performed from time to time, unless otherwise specified.

Tires* Check the pressure with a gauge periodically when at a service station, including the spare, and adjust to the specified pressure if necessary. Check carefully for damage, cuts or excessive wear.

Wheel nuts* When checking the tires, make

sure no nuts are missing, and check for any loose nuts. Tighten if necessary.

Tire rotation* Tires should be rotated every 7,500 miles (12,000 km).

Wheel alignment and balance If the vehicle should pull to either side while driving on a straight and level road, or if you detect uneven or abnormal tire wear, there may be a need for wheel alignment.

If the steering wheel or seat vibrates at normal highway speeds, wheel balancing may be needed.

Windshield wiper blades* Check for cracks or wear if they do not wipe properly.

Doors and engine hood Check that all doors and the engine hood, operate properly. Also ensure that all latches lock securely. Lubricate hinges, latches, rollers and links if necessary. Make sure that the secondary latch keeps the hood from opening when the primary latch is released.

When driving in areas using road salt or other corrosive materials, check lubrication frequently.

INSIDE THE VEHICLE

The maintenance items listed here should be checked on a regular basis, such as when performing periodic maintenance, cleaning the vehicle, etc.

Lights* Make sure that the headlights, stop lights, tail lights, turn signal lights, and other lights are all operating properly and installed securely. Also check headlight aim.

Warning lights and buzzers/chimes Make sure that all warning lights and buzzers/chimes are operating properly.

Windshield wiper and washer* Check that the wipers and washer operate properly and that the wipers do not streak.

Windshield defroster Check that the air comes out of the defroster outlets properly and in sufficient quantity when operating the heater or air conditioner.

Steering wheel Check for changes in the steering conditions, such as excessive free-play, hard steering or strange noises.

Seats Check seat position controls such as seat adjusters, seatback recliner, etc. to ensure they operate smoothly and that all

latches lock securely in every position. Check that the head restraints move up and down smoothly and that the locks (if so equipped) hold securely in all latched positions.

Seat belts Check that all parts of the seat belt system (e.g. buckles, anchors, adjusters and retractors) operate properly and smoothly, and are installed securely. Check the belt webbing for cuts, fraying, wear or damage.

Accelerator pedal Check the pedal for smooth operation and make sure the pedal does not catch or require uneven effort. Keep the floor mats away from the pedal.

Clutch pedal* Make sure the pedal operates smoothly and check that it has the proper free travel.

Brakes Check that the brakes do not pull the vehicle to one side when applied.

Brake pedal* Check the pedal for smooth operation and make sure it has the proper distance under it when depressed fully. Check the brake booster function. Be certain to keep floor mats away from the pedal.

Parking brake* Check that the lever has the

proper travel and confirm that your vehicle is held securely on a fairly steep hill with only the parking brake applied.

Automatic transmission "Park" mechanism Check that the lock release button on the selector lever operates properly and smoothly. On a fairly steep hill check that your vehicle is held securely with the selector lever in the "P" position without applying any brakes.

UNDER THE HOOD AND VEHICLE

The maintenance items listed here should be checked periodically e.g. each time you check the engine oil or refuel.

Windshield washer fluid* Check that there is adequate fluid in the tank.

Engine coolant level* Check the coolant level when the engine is cold.

Radiator and hoses Check the front of the radiator and clean off any dirt, insects, leaves, etc., that may have accumulated. Make sure the hoses have no cracks, deformation, rot or loose connections.

Brake and clutch fluid levels* Make sure that the brake and clutch fluid level is

between the "MAX" and "MIN" lines on the reservoir.

Battery* Check the fluid level in each cell. It should be between the "MAX" and "MIN" lines.

Engine drive belts* Make sure that no belt is frayed, worn, cracked or oily.

Engine oil level* Check the level after parking the vehicle on a level spot and turning off the engine.

Power steering fluid level* and lines Check the level when the fluid is cold and the engine is turned off. Check the lines for proper attachment, leaks, cracks, etc.

Automatic transmission fluid level* Check the level after putting the selector lever in "P" with the engine idling.

Exhaust system Make sure there are no loose supports, cracks or holes. If the sound of the exhaust seems unusual or there is a smell of exhaust fumes, immediately locate the trouble and correct it. (See the carbon monoxide warning in the "Starting and driving" section)

Underbody The underbody is frequently exposed to corrosive substances such as

PERIODIC MAINTENANCE

those used on icy roads or to control dust. It is very important to remove these substances, otherwise rust will form on the floor pan, frame, fuel lines and around the exhaust system. At the end of winter, the underbody should be thoroughly flushed with plain water, being careful to clean those areas where mud and dirt may accumulate. See the "Appearance and interior care" section for additional information.

Fluid leaks Check under the vehicle for fuel, oil, water or other fluid leaks after the vehicle has been parked for a while. Water dripping from the air conditioner after use is normal. If you should notice any leaks or if gasoline fumes are evident, check for the cause and have it corrected immediately.

To ensure smooth, trouble-free, safe and economical driving, NISSAN provides two different maintenance schedules that may be used, depending upon the conditions in which you usually drive. These schedules contain both distance and time intervals, up to 60,000 miles (96,000 km)/48 months. For most people, the odometer reading will indicate when service is needed. However, if you drive very little, your vehicle should be serviced at the regular time intervals shown in the schedule. **After 60,000 miles (96,000 km) or 48 months, continue periodic maintenance at the same mileage/time intervals.**

SCHEDULE 1

Follow Periodic Maintenance Schedule 1 if your driving habits frequently include one or more of the following driving conditions:

- **Repeated short trips of less than 5 miles (8 km).**
- **Repeated short trips of less than 10 miles (16 km) with outside temperatures remaining below freezing.**
- **Operating in hot weather in stop-and-go "rush hour" traffic.**

- **Extensive idling and/or low speed driving for long distances, such as police, taxi or door-to-door delivery use.**
- **Driving in dusty conditions.**
- **Driving on rough, muddy, or salt spread roads.**
- **Towing a trailer, using a camper or a car-top carrier.**

SCHEDULE 2

Follow Periodic Maintenance Schedule 2 if none of the driving conditions shown in Schedule 1 apply to your driving habits.

SCHEDULE 1

Abbreviations: R = Replace I = Inspect. Correct or replace if necessary.

[]: At the mileage intervals only

MAINTENANCE OPERATION		MAINTENANCE INTERVAL																
Perform at number of miles, kilometers or months, whichever comes first.	Miles x 1,000 (km x 1,000)	3.75 (6)	7.5 (12)	11.25 (18)	15 (24)	18.75 (30)	22.5 (36)	26.25 (42)	30 (48)	33.75 (54)	37.5 (60)	41.25 (66)	45 (72)	48.75 (78)	52.5 (84)	56.25 (90)	60 (96)	
	Months	3	6	9	12	15	18	21	24	27	30	33	36	39	42	45	48	
Emission control system maintenance																		
Drive belts	See NOTE (1)																	I*
Air cleaner filter	See NOTE (2)									[R]								[R]
Vapor lines										I*								I*
Fuel lines										I*								I*
Fuel filter	See NOTE (3)*																	
Engine coolant	See NOTE (4)																	R*
Engine oil		R	R	R	R	R	R	R	R	R	R	R	R	R	R	R	R	R
Engine oil filter	See NOTE (5)	R	R	R	R	R	R	R	R	R	R	R	R	R	R	R	R	R
Spark plugs	VE30DE engine (Use PLATINUM-TIPPED type)																	[R]
	VG30E engine									[R]								[R]
Timing belt (VG30E engine only)																		[R]

- NOTE:** (1) After 60,000 miles (96,000 km) or 48 months, inspect every 15,000 miles (24,000 km) or 12 months.
 (2) If operating mainly in dusty conditions, more frequent maintenance may be required.
 (3) If vehicle is operated under extremely adverse weather conditions or in areas where ambient temperatures are either extremely low or extremely high, the filters might become clogged. In such an event, replace them immediately.
 (4) After 60,000 miles (96,000 km) or 48 months, replace every 30,000 miles (48,000 km) or 24 months.
 (5) Use part No. 15208-60U00 or equivalent on VE30DE engine, and Nissan PREMIUM type or equivalent on VG30E engine.
 (6) Maintenance items and intervals with "*" are recommended by NISSAN for reliable vehicle operation. The owner need not perform such maintenance in order to maintain the emission warranty or manufacturer recall liability. Other maintenance items and intervals are required.

Abbreviations: I = Inspect. Correct or replace if necessary.

MAINTENANCE OPERATION	MAINTENANCE INTERVAL								
	Miles x 1,000 (km x 1,000)	7.5 (12)	15 (24)	22.5 (36)	30 (48)	37.5 (60)	45 (72)	52.5 (84)	60 (96)
Perform at number of miles, kilometers or months, whichever comes first.	Months	6	12	18	24	30	36	42	48

Chassis and body maintenance

Brake lines & cables			I		I		I		I
Brake pads, discs, drums & linings		I	I	I	I	I	I	I	I
Manual & automatic transmission	See NOTE (1).		I		I		I		I
Steering gear & linkage, axle & suspension parts		I	I	I	I	I	I	I	I
Steering linkage ball joints & front suspension ball joints		I	I	I	I	I	I	I	I
Exhaust system		I	I	I	I	I	I	I	I
Front drive shaft boots		I	I	I	I	I	I	I	I
Air bag system	See NOTE (2).								

NOTE: (1) If towing a trailer, using a camper or a car-top carrier, or driving on rough or muddy roads, change (not just inspect) oil at every 30,000 miles (48,000 km) or 24 months.

(2) Inspect the air bag system 10 years after the date of manufacture as noted on the certification label located on the left center pillar.

SCHEDULE 2

R = Replace I = Inspect. Correct or replace if necessary.

[]: At the mileage intervals only

MAINTENANCE OPERATION		MAINTENANCE INTERVAL								
Perform at number of miles, kilometers or months, which- ever comes first.	Miles x 1,000 (km x 1,000) Months	7.5 (12) 6	15 (24) 12	22.5 (36) 18	30 (48) 24	37.5 (60) 30	45 (72) 36	52.5 (84) 42	60 (96) 48	
Emission control system maintenance										
Drive belts	See NOTE (1)									I*
Air cleaner filter						[R]				[R]
Vapor lines						I*				I*
Fuel lines						I*				I*
Fuel filter	See NOTE (2)*									
Engine coolant	See NOTE (3)									R*
Engine oil		R	R	R	R	R	R	R	R	R
Engine oil filter	See NOTE (4)		R		R		R		R	R
Spark plugs	VE30DE engine (Use PLATINUM-TIPPED type)									[R]
	VG30E engine					[R]				[R]
Timing belt (VG30E engine only)										[R]

- NOTE:** (1) After 60,000 miles (96,000 km) or 48 months, inspect every 15,000 miles (24,000 km) or 12 months.
 (2) If vehicle is operated under extremely adverse weather conditions or in areas where ambient temperatures are either extremely low or extremely high, the filters might become clogged. In such an event, replace them immediately.
 (3) After 60,000 miles (96,000 km) or 48 months, replace every 30,000 miles (48,000 km) or 24 months.
 (4) Use part No. 15208-60U00 or equivalent on VE30DE engine, and Nissan PREMIUM type or equivalent on VG30E engine.
 (5) Maintenance items and intervals with "*" are recommended by NISSAN for reliable vehicle operation. The owner need not perform such maintenance in order to maintain the emission warranty or manufacturer recall liability. Other maintenance items and intervals are required.

Abbreviations: I = Inspect. Correct or replace if necessary.

MAINTENANCE OPERATION		MAINTENANCE INTERVAL							
		Miles x 1,000	7.5	15	22.5	30	37.5	45	52.5
Perform at number of miles, kilometers or months, whichever comes first.	(km x 1,000)	(12)	(24)	(36)	(48)	(60)	(72)	(84)	(96)
	Months	6	12	18	24	30	36	42	48
	Chassis and body maintenance								
Brake lines & cables			I			I		I	
Brake pads, discs, drums & linings						I		I	
Manual & automatic transmission						I		I	
Steering gear linkage, axle & suspension parts						I			I
Exhaust system						I		I	
Front drive shaft boots						I		I	
Air bag system		See NOTE (1).							

NOTE: (1) Inspect the air bag system 10 years after the date of manufacture as noted on the certification label located on the left center pillar.

EXPLANATION OF MAINTENANCE ITEMS

Additional information on the following items with “*” is found in the “Do-it-yourself operations” section.

Emission control system maintenance

Drive belts* Check drive belts for wear, fraying or cracking and also for proper tension. Replace the drive belts if found damaged.

Air cleaner filter Under normal driving conditions, the air cleaner filter should be replaced in accordance with the maintenance schedule. However, driving the vehicle in dusty areas may cause more rapid clogging of the element. Consequently, the element may have to be replaced more frequently.

Vapor lines Check vapor lines and connections for failure or looseness. If leaks are found, replace them.

Fuel lines Check the fuel hoses, piping and connections for leaks, looseness or deterioration. Replace any parts if they are damaged.

Fuel filter If the vehicle is operated under extremely adverse weather conditions or in areas where ambient temperatures are either extremely low or extremely high, the filter might become clogged. In such an event, replace the filter immediately.

Engine coolant* Drain and flush the cooling system.

Engine oil & oil filter* Under normal driving conditions, the engine oil and oil filter should be replaced in accordance with the maintenance schedule. However, under severe driving conditions, they may have to be replaced more frequently.

Spark plugs* Replace with new plugs having the correct heat range.

Timing belt Replace the timing belt for driving the camshafts.

Chassis and body maintenance

Brake lines & cables Check the brake lines and hoses (including brake booster vacuum hoses, connections & check valve) and parking brake cables for proper attachment, leaks, cracks, chafing, abrasion, deterioration, etc.

Brake pads, discs, drums & linings Check

these and the other neighboring brake components for wear, deterioration and leaks. Under severe driving conditions, they may have to be inspected more frequently.

Manual & automatic transmission gear oil* Check the oil level and visually inspect for signs of leakage.

Under severe driving conditions, the oil should be replaced at the specified interval.

Steering gear & linkage, axle & suspension parts, and drive shaft boots Check for damage, looseness and leakage of oil or grease. Under severe driving conditions, more frequent inspection should be performed.

Steering linkage ball joints & front suspension ball joints Check the ball joints for damage, looseness and grease leakage.

Exhaust system Visually check the exhaust pipes, muffler, and hangers for proper attachment, leaks, cracks, chafing, abrasion, deterioration, etc. Under severe driving conditions, inspection should be performed more frequently.

Air bag system Check the air bag system components for proper attachment, dam-

age, deformities, cracks rust, etc. Work around and on the air bag system should be done by an authorized NISSAN dealer.

MEMO

9 Technical and consumer information

Capacities and recommended	
fuel/lubricants.....	9-2
Engine.....	9-7
Wheels & tires.....	9-8
Dimensions and weights.....	9-8
When traveling or registering your	
vehicle in another country.....	9-9
Vehicle identification.....	9-9
Installing license plate.....	9-12
Trailer towing.....	9-13
Uniform tire quality grading.....	9-16
Emission control system warranty.....	9-16
Reporting safety defects.....	9-17



CAPACITIES AND RECOMMENDED FUEL/LUBRICANTS

The following are approximate capacities. The actual refill capacities may be a little different. When refilling, follow the procedure instructed in the "Do-it-yourself operations" section to determine the proper refill capacity.

Fuel		Capacity (Approximate)			Recommended Fuel/Lubricants	
		US measure	Imp measure	Liter		
Fuel		18-1/2 gal	15-3/8 gal	70	Unleaded gasoline with an octane rating of at least 91 AKI (RON 96) or 87 AKI (RON 91)*1	
Engine oil (Refill)						
With oil filter	VG30E	4-1/8 qt	3-3/8 qt	3.9	Energy Conserving Oils of API SG*2, *3	
	VE30DE	4 qt	3-3/8 qt	3.8		
Without oil filter	VG30E	3-3/4 qt	3-1/8 qt	3.5		
	VE30DE	3-5/8 qt	3 qt	3.4		
Cooling system						
With reservoir	VG30E	9-3/8 qt	7-7/8 qt	8.9		Anti-freeze coolant (Ethylene glycol base)
	VE30DE	11-1/4 qt	9-3/8 qt	10.6		
Reservoir	VG30E	5/8 qt	1/2 qt	0.6		
	VE30DE	3/4 qt	5/8 qt	0.7		
Manual transmission gear oil		—	—	—	API GL-4*3	
Automatic transmission fluid					Genuine Nissan ATF*4 or equivalent Type DEXRON™II-E	
Power steering fluid		Refill to the proper oil level according to the instructions in the "Do-it-yourself operations" section.			Type DEXRON™II or equivalent	
Brake and clutch fluid					Genuine Nissan Brake Fluid*4 or equivalent DOT 3 (US FMVSS No. 116)	
Multi-purpose grease		—	—	—	NLGI No. 2 (Lithium soap base)	
Air conditioning system refrigerant		—	—	—	R-134a	
Air conditioning system lubricants		—	—	—	Nissan A/C System Oil Type S or exact equivalent	

*1: For further details, see "Fuel recommendation".

*2: For further details, see "Engine oil and oil filter recommendation".

*3: For further details, see "Recommended SAE viscosity number".

*4: Available in mainland U.S.A. through your Nissan dealer.

FUEL RECOMMENDATION

VG30E engine models

Unleaded gasoline with an octane rating of at least 87 AKI (Anti-Knock Index) number (Research octane number 91).

For improved vehicle performance, the use of premium unleaded gasoline with an octane rating of at least 91 AKI number (Research octane number 96) is recommended.

VE30DE engine models

Unleaded premium gasoline with an octane rating of at least 91 AKI (Anti-Knock Index) number (Research octane number 96)

If unleaded premium gasoline is not available, unleaded regular gasoline with an octane rating of at least 87 AKI (Research octane number 91) can be used.

However, for maximum vehicle performance, the use of unleaded premium gasoline is recommended.

CAUTION:

Using a fuel other than that specified could adversely affect the emission control de-

vices and systems, and could also affect the warranty coverage validity.

Under no circumstances should a leaded gasoline be used, since this will damage the three-way catalyst.

Gasoline containing oxygenates

Some fuel suppliers sell gasoline containing oxygenates such as ethanol, MTBE and methanol with or without advertising their presence. Nissan does not recommend the use of fuels of which the oxygenate content and the fuel compatibility for your Nissan cannot be readily determined. If in doubt, ask your service station manager.

If you use oxygenate-blend gasoline, please take the following precautions as the usage of such fuels may cause vehicle performance problems and/or fuel system damage.

- **The fuel should be unleaded and have an octane rating no lower than that recommended for unleaded gasoline.**
- **If an oxygenate-blend, excepting a methanol blend, is used, it should contain no more than 10% oxygenate. (MTBE may, however, be added up to 15%.)**

- **If a methanol blend is used, it should contain no more than 5% methanol (methyl alcohol, wood alcohol). It should also contain a suitable amount of appropriate cosolvents and corrosion inhibitors. If not properly formulated with appropriate cosolvents and corrosion inhibitors, such methanol blends may cause fuel system damage and/or vehicle performance problems. At this time, sufficient data is not available to ensure that all methanol blends are suitable for use in Nissan vehicles.**

If any undesirable driveability problems such as engine stalling and hard hot starting are experienced after using oxygenate-blend fuels, immediately change to a non-oxygenate fuel or a fuel with a low blend of MTBE.

Take care not to spill gasoline during refueling. Gasoline containing oxygenates can cause paint damage.

Octane rating tips

In most parts of North America, you should use unleaded gasoline with an octane rating of at least 87 or 91 AKI (Anti-Knock Index) number. However, you may use un-

leaded gasoline with an octane rating as low as 85 AKI (Anti-Knock Index) number in these high altitude areas [over 4,000 ft (1,219 m)] such as: Colorado, Montana, New Mexico, Utah, Wyoming, northeastern Nevada, southern Idaho, western South Dakota, western Nebraska, and that part of Texas which is directly south of New Mexico.

Using unleaded gasoline with an octane rating lower than stated above can cause persistent, heavy "spark knock." ("Spark knock" is a metallic rapping noise.) If severe, this can lead to engine damage. If you detect a persistent heavy spark knock even when using gasoline of the stated octane rating, or if you hear steady spark knock while holding a steady speed on level roads, have your dealer correct the condition. Failure to correct the condition is misuse of the vehicle, for which NISSAN is not responsible.

Incorrect ignition timing will result in knocking, after-run or overheating. This in turn may cause excessive fuel consumption or damage to the engine. If any of the above symptoms are encountered, have your vehicle checked at a NISSAN dealer or other

competent service facility.

However, now and then you may notice light spark knock for a short time while accelerating or driving up hills. This is no cause for concern, because you get the greatest fuel benefit when there is light spark knock for a short time under heavy engine load.

ENGINE OIL AND OIL FILTER RECOMMENDATION

Selecting the correct oil

An API SG quality, SAE 5W-30 and energy conserving oil is the preferred engine oil for your vehicle.

There are three oil characteristics which must be considered when selecting the correct engine oil. They are quality, viscosity and frictional characteristics. It is essential that the correct quality and viscosity oil is chosen to ensure satisfactory life and performance of the engine. It is further recommended on the gasoline engine that a low friction oil (energy conserving oil) be selected in order to improve fuel economy and conserve energy. **Oil which may contain foreign matter or has been previously**

used should not be used.

Oil quality

The quality of the engine oil is shown on the container in accordance with API (American Petroleum institute) designations of quality.

Oils which do not have the specified quality label should not be used as they could cause engine damage.

Only energy conserving oils of API SG should be used. These oils may have single or combined designators (i.e., "SG", "SG/CC" or "SG/CD").

Oil viscosity

The engine oil viscosity or thickness changes with temperature. Because of this, it is important that the engine oil viscosity be selected based on the temperatures at which the vehicle will be operated before the next oil change. The following chart "Recommended SAE viscosity number" shows the recommended oil viscosities for the expected ambient temperatures. Choosing an oil viscosity other than that recommended could cause serious engine damage.

Energy conserving oils

In order to improve fuel economy and conserve energy, new lower friction engine oils have been developed. These oils are readily available and can be identified by such labels as EC-I, EC-II, energy conserving, energy saving, improved fuel economy, etc.

Oil identification

A standard symbol may be used to help you select the correct oil. A typical symbol is shown below, the upper portion designates the quality, the center designates the viscosity and the lower section indicates that the oil has fuel saving capabilities.



Selecting the correct oil filter

Your new vehicle is equipped with a high-

quality genuine Nissan oil filter. When replacing, use the genuine oil filter or its equivalent for the reason described in "change intervals".

- extensive idling,
- towing a trailer.

Change intervals

The oil and oil filter change intervals for your engine are based on the use of the specified quality oils and filters. Oil and filter other than the specified quality, or oil and filter change intervals longer than recommended could reduce engine life. Damage to engines caused by improper maintenance or use of incorrect oil and filter quality and/or viscosity is not covered by the new Nissan vehicle warranties.

Your engine was filled with a high quality engine oil when it was built. You do not have to change the oil before the first recommended change interval. Oil and filter change intervals depend upon how you use your vehicle. Operation under the following conditions may require more frequent oil and filter changes.

- repeated short distance driving at cold outside temperatures,
- driving in dusty conditions,

RECOMMENDED SAE VISCOSITY NUMBER

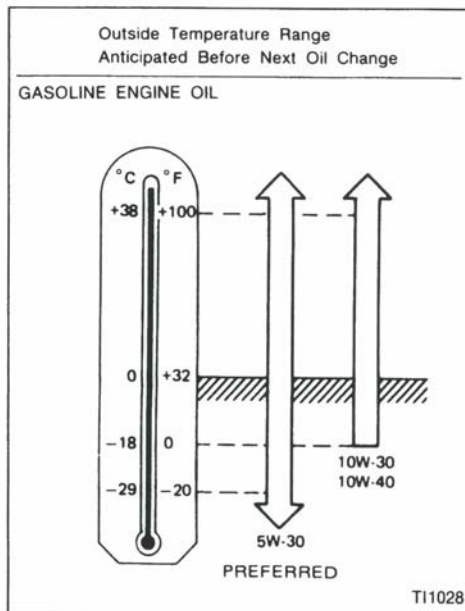

- 5W-30 is preferable for all ambient temperatures.

20W-40 and 20W-50 are usable for ambient temperatures above 50°F (10°C) for all seasons.

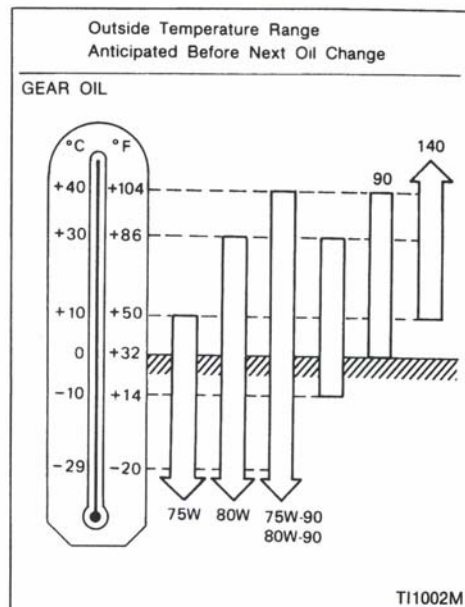

- 80W-90 is preferable for ambient temperatures below 104°F (40°C).

ENGINE

Air conditioning system refrigerant and lubricant recommendations

The air conditioning system in this NISSAN vehicle must be charged with the refrigerant R-134a and the lubricant, Nissan A/C System Oil Type R or the exact equivalents. Use of any other refrigerant or lubricant will cause severe damage and you will need to replace your vehicle's entire air conditioning system.

The release of refrigerant into the atmosphere is not recommended. The new refrigerant R-134a in your NISSAN vehicle will not harm the earth's ozone layer. However, it may contribute in a small part to global warming. NISSAN recommends that the refrigerant be recovered and recycled.

Model		VG30E	VE30DE
Type		Gasoline, 4-cycle	←
Cylinder arrangement		6-cylinder, V-slanted at 60°	←
Bore x Stroke	in (mm)	3.425 x 3.268 (87.0 x 83.0)	←
Displacement	cu in (cm ³)	180.62 (2,960)	←
Firing order		1-2-3-4-5-6*	←
Idle speed	rpm	See the "Emission Control Label" on the underside of the hood.	
Ignition timing (B.T.D.C.)	degree/rpm		
CO percentage at idle speed	[No air] %		
Spark plug	Standard	BKR5ES-11	PFR5C-11
	Service option	BKR6ES-11, BKR7ES-11	PFR4C-11, PFR6C-11
Spark plug gap	in (mm)	0.039 to 0.043 (1.0 to 1.1)	—
Alternator belt size			
Width x Length	in (mm)	0.559 x 30.51 (14.2 x 775)	0.701 x 33.66 (17.8 x 855)

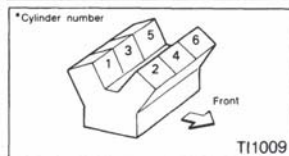

WHEELS AND TIRES

Road wheel	Aluminum	15 x 6JJ, 15 x 6.5JJ
	Offset in (mm)	1.38 (35)
Tire size	Conventional	P205/65R15 P205/65VR15*
	Spare	T125/70D16

*: VE30DE engine with manual transaxle for U.S.A.

DIMENSIONS AND WEIGHTS

			Sedan
Overall length	in (mm)		187.6 (4,765)
Overall width	in (mm)		69.3 (1,760)
Overall height	in (mm)		55.1 (1,400)
Front tread	in (mm)		59.4 (1,510)
Rear tread	in (mm)		58.7 (1,490)
Wheelbase	in (mm)		104.3 (2,650)
Gross vehicle weight rating	lb (kg)		
Gross axle weight rating			See the "F.M.V.S.S. certification label" on the driver's side lock pillar.
Front	lb (kg)		
Rear	lb (kg)		

WHEN TRAVELING OR REGISTERING YOUR VEHICLE IN ANOTHER COUNTRY

When planning to travel in another country, you should first find out if the fuel available is suitable for your vehicle's engine.

Using fuel with too low an octane/cetane rating may cause engine damage. All gasoline vehicles must be operated with unleaded engine gasoline. Therefore, avoid taking your vehicle to areas where appropriate fuel is not available.

When transferring the registration of your vehicle to another country, state, province or district, it may be necessary to modify the vehicle to meet local laws and regulations.

The laws and regulations for motor vehicle emission control and safety standards vary according to the country, state, province or district; therefore, vehicle specifications may differ.

When any vehicle is to be taken into another country, state, province or district and registered, its modifications, transportation, and registration are the responsibility of the user. NISSAN is not responsible for any inconvenience that may result.

VEHICLE IDENTIFICATION

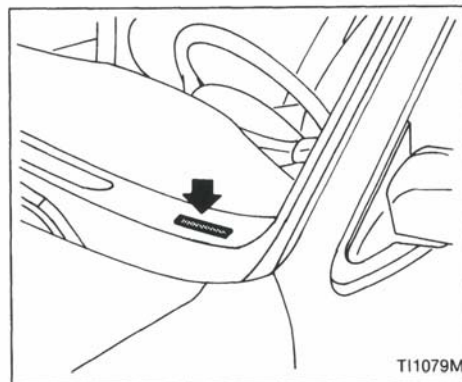

VEHICLE IDENTIFICATION NUMBER PLATE

The vehicle identification number plate is attached as shown. This number is the identification for your vehicle and is used in the vehicle registration.

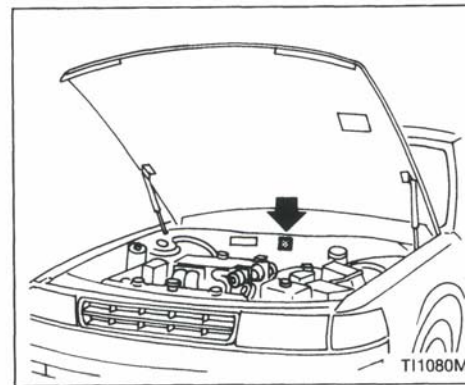

VEHICLE IDENTIFICATION PLATE

The number plate is affixed as shown.

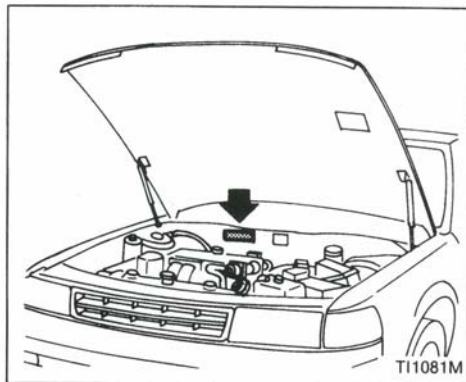

VEHICLE IDENTIFICATION NUMBER (Chassis number)

The number is stamped as shown.

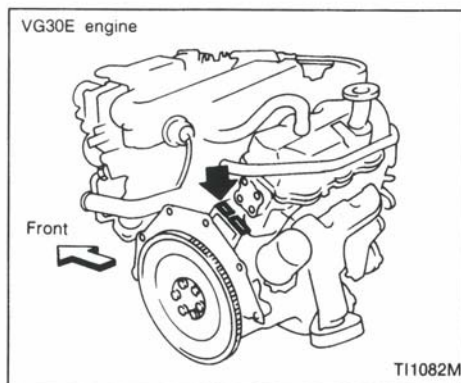

ENGINE SERIAL NUMBER

The number is stamped on the engine as shown.

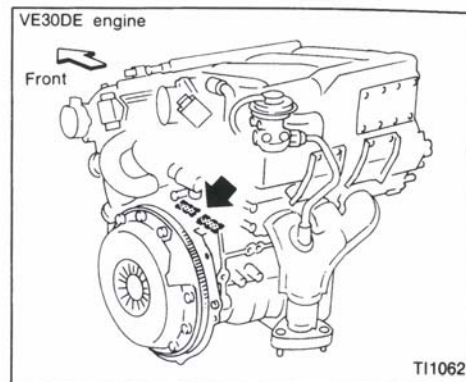

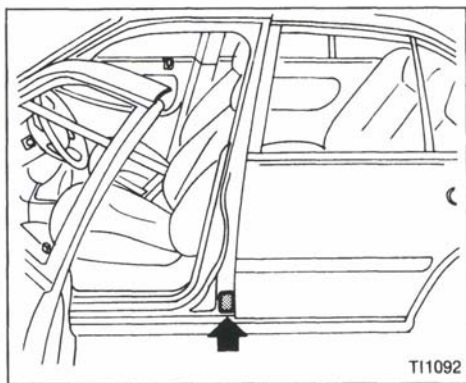

F.M.V.S.S. CERTIFICATION LABEL

The F.M.V.S.S. certification label is affixed as shown.

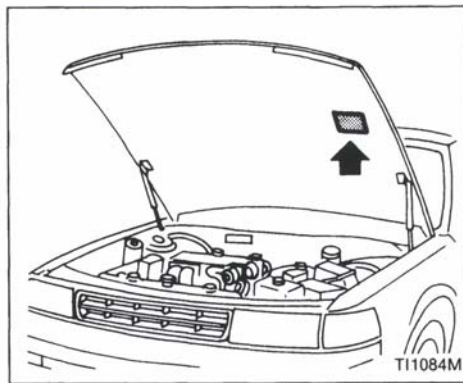

EMISSION CONTROL INFORMATION LABEL

The emission control information label is attached as shown.

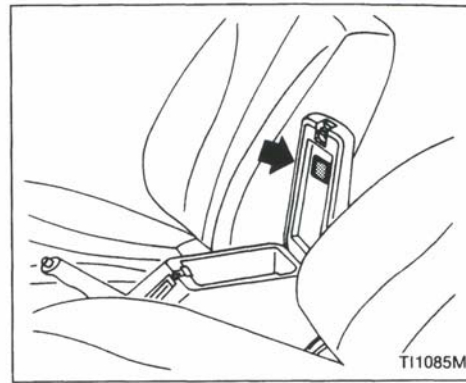

TIRE PLACARD

The cold tire pressure is shown on the tire placard affixed to the center console lid.

INSTALLING LICENSE PLATE

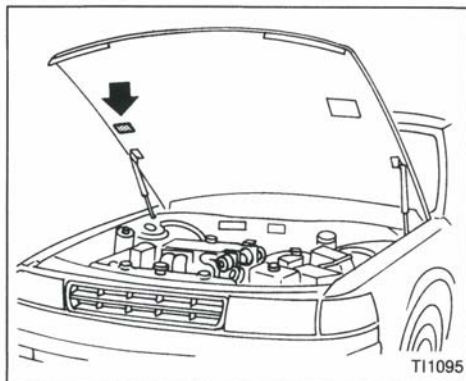

AIR CONDITIONER SPECIFICATION LABEL

The label is affixed inside of the hood as shown.

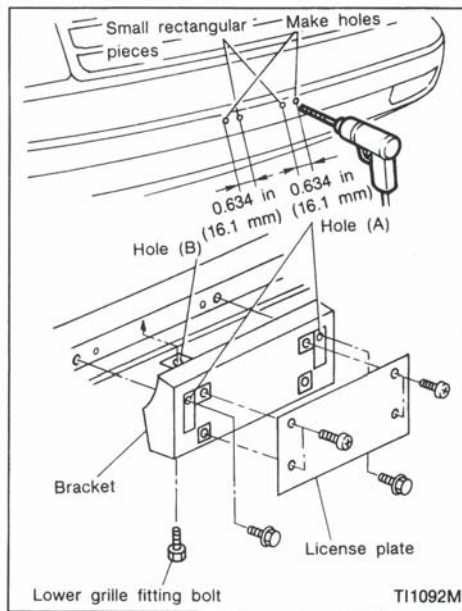

Use the following steps to mount the license plate:

1. Make a hole in each plastic finisher using a 0.31 in (8 mm) drill. For your reference, instructions for making the

holes are shown. To avoid damaging the threads behind the finisher, apply only light pressure to the drill.

2. Mount the license bracket, inserting the bolts which are included in the mounting bracket kit through hole (A) and inserting the lower grille fitting bolt through hole (B).
3. Mount the license plate with the screws. [0.31 in (8 mm) machine screw]. The screws for mounting the license plate are not included in the mounting bracket kit.

TRAILER TOWING

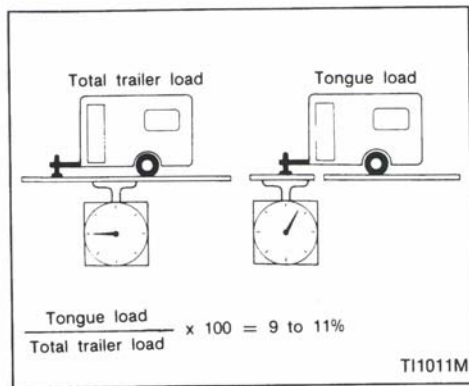

Your new vehicle was designed to be used primarily to carry passengers and cargo. Remember that towing a trailer will place additional loads on your vehicle's engine, drive train, steering, braking and other systems.

Information on trailer towing ability and the special equipment required should be obtained from your Nissan dealer. He can obtain a **Nissan Trailer Towing Guide** for you.

Maximum load limits

Maximum trailer loads

Never allow the total trailer load to exceed 1,000 lb (454 kg). The total trailer load equals trailer weight plus its cargo weight. Towing loads greater than 1,000 lb (454 kg) or using improper towing equipment could adversely affect vehicle handling, braking and performance.

WARNING:

Vehicle damage and/or personal injury resulting from improper towing procedures is not covered by NISSAN warranties. Information on trailer towing and required towing equipment should be obtained from dealers who specialize in providing trailers or other towing equipment.

Tongue load

Keep the tongue load between 9 and 11% of the total trailer load. If the tongue load becomes excessive, rearrange cargo to allow for proper tongue load.

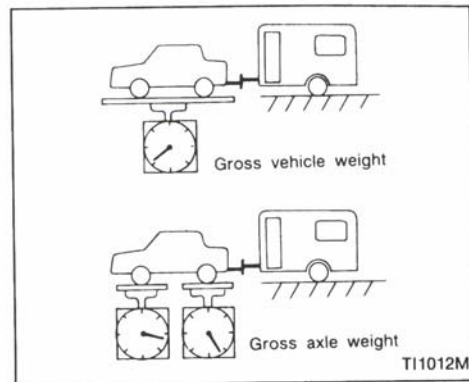

Maximum gross vehicle weight/maximum gross axle weight

The gross vehicle weight of the towing vehicle must not exceed the gross vehicle weight rating (GVWR) shown on the F.M.V.S.S. certification label. The gross vehicle weight equals the combined weight of the unloaded vehicle, passengers, luggage, hitch, trailer tongue load and any other optional equipment. In addition, front or rear gross axle weight must not exceed the gross axle weight rating (GAWR) shown on the F.M.V.S.S. certification label.

Trailer hitch

Choose a proper hitch for your vehicle and trailer. Make sure the trailer hitch is securely attached to the vehicle, to help avoid personal injury or property damage due to sway caused by crosswinds, rough road surfaces or passing trucks.

- Axle-mounted hitches should not be used.
- The hitch should not be attached to or affect the operation of the impact-absorbing bumper
- Do not modify the vehicle exhaust system, brake system, etc. when the hitch is installed.
- To reduce the possibility of additional damage if your vehicle is struck from the rear, remove the hitch when not in use. After the hitch is removed, seal the bolt holes to prevent exhaust fumes, water or dust from entering the passenger compartment.
- Regularly check that all hitch mounting bolts are securely mounted.

Tire pressures

- When towing a trailer, inflate the vehicle tires to the recommended cold tire pressure indicated on the tire placard (located on the inside of the center console lid.)
- Trailer tire condition, size, load rating and proper inflation pressure should be in accordance with the trailer and tire manufacturers' specifications.

Safety chain

Always use a suitable chain between your vehicle and the trailer. The chain should be crossed and should be attached to the hitch, not to the vehicle bumper or axle. Be sure to leave enough slack in the chain to permit turning corners.

Trailer lights

Trailer lights should comply with Federal and/or local regulations. When wiring the vehicle for towing, connect the stop and tail light pickup into the vehicle electrical circuit at a point between the sensor and stop light or light switch.

Trailer brakes

If your trailer is equipped with a braking system, make sure it conforms to Federal and/or local regulations and that it is properly installed.

CAUTION:

Never connect a trailer brake system directly to the vehicle brake system.

Pre-towing tips

- Be certain your vehicle maintains a level position when a loaded and/or unloaded trailer is hitched. Do not drive the vehicle if it has an abnormal nose-up or nose-down condition; check for improper tongue load, overload, worn suspension or other possible causes of either condition.
- Always secure items in the trailer to prevent load shifts while driving.
- Be certain your rear view mirrors conform to all federal, state or local regulations. If not, install any mirrors required for towing before driving the vehicle.

Trailer towing tips

In order to gain skill and an understanding of the vehicle's behavior, you should prac-

tice turning, stopping and backing up in an area which is free from traffic. Steering stability, and braking performance will be somewhat different than under normal driving conditions.

- Always secure items in the trailer to prevent load shift while driving.
- Avoid abrupt starts, acceleration or stops.
- Avoid sharp turns or lane changes.
- Always drive your vehicle at a moderate speed.
- Always block the wheels on both vehicle and trailer when parking. Parking on a slope is not recommended; however, if you must do so, and if your vehicle is equipped with automatic transmission, first block the wheels and apply the parking brake, and then move the transmission shift lever into the "P" position. If you move the shift lever to the "P" position before blocking the wheels and applying the parking brake, transmission damage could occur.
- When going down a hill, shift into a lower gear and use the engine braking effect.

When ascending a long grade, downshift the transmission to a lower gear and reduce speed to reduce chances of engine overloading and/or overheating.

- If the engine coolant rises to an extremely high temperature when the air conditioning system is on, turn off the air conditioner. Coolant heat can be additionally vented by opening the windows, switching the fan control to high and setting the temperature control to the "HOT" position.
- Trailer towing requires more fuel than normal circumstances.
- Avoid towing a trailer for the first 500 miles (800 km).
- Have your vehicle serviced more often than at intervals specified in the recommended Maintenance Schedule.
- When making a turn, your trailer wheels will be closer to the inside of the turn than your vehicle wheels. To compensate for this, make a larger than normal turning radius during the turn.
- Crosswinds and rough roads will adversely affect vehicle/trailer handling,

possibly causing vehicle sway. When being passed by larger vehicles, be prepared for possible changes in crosswinds that could affect vehicle handling. If swaying does occur, firmly grip the steering wheel, steer straight ahead, and immediately (but gradually) reduce vehicle speed. This combination will help stabilize the vehicle. Never increase speed.

- Be careful when passing other vehicles. Passing while towing a trailer requires considerably more distance than normal passing. Remember the length of the trailer must also pass the other vehicle before you can safely change lanes.
- To maintain engine braking efficiency and electrical charging performance, do not use fifth gear (manual transmission) or overdrive (automatic transmission).
- Avoid holding the brake pedal down too long or too frequently. This could cause the brakes to overheat, resulting in reduced braking efficiency.

When towing a trailer, change oil in the transmission more frequently.

See the Maintenance schedule.

UNIFORM TIRE QUALITY GRADING

DOT Quality Grades: All passenger car tires must conform to Federal Safety Requirements in addition to these grades.

Treadwear

Treadwear grade is a comparative rating based on tire wear rate when tested under controlled conditions on specified government test courses. For example, a tire graded 150 would wear one and a half (1-1/2) times as well on the government course as a tire graded 100. However, relative tire performance depends on actual driving conditions, and may vary significantly from the norm due to variations in driving habits, service practices and differences in road characteristics and climate.

Traction A, B and C

Traction grades are A (the highest), B and C. They represent a tire's ability to stop on wet pavement as measured under controlled conditions, on specified government test surfaces of asphalt and concrete. A tire marked with a C may have poor traction performance.

WARNING:

The traction grade assigned to your vehicle

tires is based on straight line braking traction tests and does not include cornering (turning) traction.

Temperature A, B and C

Temperature grades are A (the highest), B, and C. They represent a tire's resistance to heat build-up, and its ability to dissipate heat when tested under controlled conditions on a specified indoor laboratory test wheel. Sustained high temperature can cause tire material to degenerate, reducing tire life. Excessive temperatures can lead to sudden tire failure. Grade C corresponds to a performance level which all passenger car tires must meet under the Federal Motor Vehicle Safety Standard No. 109. Grades A and B represent higher levels of performance on laboratory test wheels than the minimum required by law.

WARNING:

The temperature grade for this tire is established for a tire that is properly inflated and not overloaded. Excessive speed, underinflation, or excessive loading, either separately or in combination, can cause heat buildup and possible tire failure problems.

EMISSION CONTROL SYSTEM WARRANTY

Your NISSAN is covered by the following emission warranties.

For U.S.A.

- 1) Emission Defects Warranty
- 2) Emissions Performance Warranty

For Canada

Emission Control System Warranty

Details of these warranties may be found with other vehicle warranties in your warranty information booklet that comes with your NISSAN. If you did not receive a warranty information booklet, or it has become lost, you may obtain a replacement by writing to:

- Nissan Motor Corporation in U.S.A.
Consumer Affairs Department
P.O. Box 191
Gardena. Ca. 90247
- Nissan Canada Inc.
P.O. Box 1709,
Station "B"
Mississauga, Ontario,
L4Y 4H6

REPORTING SAFETY DEFECTS

If you believe that your vehicle has a defect which could cause a crash or could cause injury or death, you should immediately inform the National Highway Traffic Safety Administration (NHTSA) in addition to notifying NISSAN.

If NHTSA receives similar complaints, it may open an investigation, and if it finds that a safety defect exists in a group of vehicles, it may order a recall and remedy campaign. However, NHTSA cannot become involved in individual problems between you, your dealer, or NISSAN.

To contact NHTSA, you may either call the Auto Safety Hotline toll-free at 1-800-424-9393 (or 366-0123 in Washington, D.C. area) or write to: NHTSA, U.S. Department of Transportation, Washington, D.C. 20590. You can also obtain other information about motor vehicle safety from the Hotline.

You may notify NISSAN by contacting our Consumer Affairs Department, toll-free, at 1-800-NISSAN-1.
In Hawaii call 531-0231.



Genuine Nissan Service Manuals

GET THE INSIDE STORY

A Genuine Nissan Service Manual is the best source of service and repair information for your vehicle. Filled with wiring diagrams, illustrations and step-by-step diagnostic and adjustment procedures, this manual is the same one used by the factory trained technicians working at your Nissan dealership.

For a copy, see your NISSAN dealer or send a check or money order to:

In U.S.A.: Dyment Distribution Services
20770 Westwood Road
Strongsville, Ohio, 44136

In Canada: Nissan Canada Inc.
P.O. Box 1709,
Station "B"
Mississauga, Ontario
L4Y 4H6

MODEL	SERVICE MANUAL			OWNER'S MANUAL		
	PART NUMBER	U.S.A.	CANADA	PART NUMBER	U.S.A.	CANADA
1993 Maxima	2J3093	\$50.00	—	3J3093	\$8.00	—
1993 Maxima	2J3093	—	\$45.95	3J3093C	—	\$6.50

California and Ohio residents add 6.5% tax.

Yes! We also have service manuals for older models. Write for a free catalog.

In a hurry? Call 1-800-247-5321 and charge your purchase to Visa/Master Card.

Prices listed are for Dyment Distribution Services and Nissan Canada Inc., and are suggested retail prices. Dealer prices may vary. Prices are subject to change without notice.

10 Index

A

Air bag information and warning labels	2-12
Air bag warning light	2-11
Air cleaner filter	7-18
Air conditioner	
Air conditioner operation.....	3-5
Automatic air conditioner	3-10
Heater and air conditioner	3-3
Air flow chart.....	3-6
AM-FM radio with cassette player	3-22
AM-FM radio with cassette player (Active speaker system).....	3-18
AM-FM radio with cassette player and compact disc player	3-25
AM-FM radio with cassette player (Bose audio system).....	3-14
Analog (Needle-type) meter.....	1-6
Anti-lock brake system.....	4-16
Automatic	
Automatic air conditioner	3-10
Automatic seat belt system (For U.S.A.)	2-17
Automatic transmission fluid	7-11
Driving with automatic transmission.....	4-5
Installation on front passenger seat (For U.S.A.- automatic seat belt)	2-29
Seat belt extenders (Except for the	

automatic seat belt).....	2-25
---------------------------	------

B

Battery.....	7-14
Before starting the engine	4-5
Brake	
Anti-lock brake system.....	4-15
Brake and clutch fluid	7-13
Brake booster.....	7-20
Brake pedal	7-20
Parking brake	4-11, 7-19
Break-in schedule.....	4-13

C

Capacities and recommended fuel/lubricants.....	9-2
CB radio or car phone	3-31
Changing	
Changing engine coolant.....	7-6
Changing engine oil.....	7-9
Changing oil filter.....	7-10
Check locations in engine compartment.....	7-3
Checking engine coolant level	7-6
Checking engine oil level	7-8
Child restraint systems for infants and small children	2-25

Child safety rear door lock.....	2-3
Cigarette lighter and ash trays.....	1-17
Cleaning exterior and interior	6-2
Clock.....	1-21
Clutch pedal	7-21
Cold weather driving cautions.....	4-17
Compact disc (CD) player operation	3-29
Controls.....	3-3
Coolant	
Changing engine coolant.....	7-6
Checking engine coolant level	7-6
Engine coolant temperature gauge.....	1-5, 1-7
Cornering light.....	1-16
Corrosion protection	6-4
Cruise control	4-12

D

Defogger switch	
Outside mirror defogger switch	1-14
Rear window defogger switch	1-14
Digital (Electronic) meter	1-3
Digital touch entry system	2-4
Dimensions and weights.....	9-8
Door locks.....	2-2
Drinking alcohol/drugs and driving.....	4-3
Drive belts.....	7-15

Driving	
Cold weather driving cautions.....	4-17
Drinking alcohol/drugs and driving.....	4-3
Driving with automatic transmission.....	4-5
Driving with manual transmission	4-9
Precautions when driving	4-16
Precautions when starting and driving...	4-2

E

Economy hints	4-14
Emission control information label.....	9-11
Emission control system warranty	9-16
Engine	9-7
Before starting the engine.....	4-5
Changing engine coolant.....	7-6
Changing engine oil.....	7-9
Check locations in engine compartment.....	7-3
Checking engine coolant level	7-6
Checking engine oil level	7-8
Engine coolant temperature gauge.....	1-5, 1-7
Engine cooling system.....	7-5
Engine oil.....	7-8
Engine oil and oil filter recommendation.....	9-4
Engine serial number.....	9-10
Starting the engine.....	4-10
Exhaust gas (Carbon monoxide)	4-2
Explanation of maintenance items	8-10

F

Flat tire.....	5-2
Fluid	
Automatic transmission fluid	7-11
Brake and clutch fluid	7-13
Power steering fluid	7-13
Window washer fluid	7-14
F.M.V.S.S. certification label	9-11
Foot vent	3-2
Freeing vehicle from sand, snow or mud..	5-10
Front fog light switch.....	1-16
Front personal light	1-22
Fuel	
Capacities and recommended fuel/lubricants.....	9-2
Fuel filler cap	2-9
Fuel filler lid lock	2-8
Fuel gauge.....	1-5, 1-8
Fuel recommendation	9-2
Fuses.....	7-21
Fusible links.....	7-23

G

Gauge	
Engine coolant temperature gauge.....	1-5, 1-7
Fuel gauge.....	1-5, 1-8
General maintenance.....	8-3
Glove box lock.....	2-7

H

Hazard warning flasher switch	1-17
Head restraint.....	2-15
Headlight and turn signal switch.....	1-15
Headlights	7-24
Heater and air conditioner.....	3-3
Heater operation.....	3-4
Hood release	2-6

I

If the sun roof does not close.....	1-20
If your vehicle overheats	5-7
Ignition switch.....	4-3
Inside mirror	2-33
Inside the vehicle	8-3
Installation on front passenger seat (For U.S.A.- automatic seat belt)	2-29
Installing license plate	9-12
Instrument brightness control.....	1-16
Interior light	1-22

J

Jump starting.....	5-6, 7-15
--------------------	-----------

K

Key	2-2
-----------	-----

L

License plate	
Installing license plate.....	9-12
Light	
Air bag warning light.....	2-11
Cornering light.....	1-16
Front fog light switch.....	1-16
Front personal light.....	1-22
Headlight and turn signal switch.....	1-15
Headlights.....	7-24
Interior light.....	1-22
Light bulbs.....	7-23
Other lights.....	7-24
Warning/indicator light and chime.....	1-9

Lock

Anti-lock brake system.....	4-15
Child safety rear door lock.....	2-3
Door locks.....	2-2
Fuel filler lid lock.....	2-8
Glove box lock.....	2-7
Power door lock.....	2-3
Trunk lid lock.....	2-7

M**Maintenance**

Explanation of maintenance items.....	8-10
General maintenance.....	8-3
Periodic maintenance.....	8-5
Seat belt maintenance.....	2-25

Mirror

Inside mirror.....	2-33
Outside mirror defogger switch.....	1-14
Outside mirrors.....	2-32

O

Odometer.....	1-4, 1-7
Oil	
Changing engine oil.....	7-9
Changing oil filter.....	7-10
Checking engine oil level.....	7-8
Engine oil.....	7-8
Engine oil and oil filter recommendation.....	9-4
Opener cancel lever for trunk lid.....	2-8
Other lights.....	7-24
Outside mirror defogger switch.....	1-14
Outside mirrors.....	2-33
Overheat	
If your vehicle overheats.....	5-7

P**Parking**

Parking brake.....	4-11, 7-19
Parking/parking on hills.....	4-15
Periodic maintenance.....	8-5
Pocket and cup holder.....	1-18
Power	
Power antenna.....	3-31
Power door lock.....	2-3
Power steering fluid.....	7-12
Power support seat.....	2-14

Power window.....	1-19
Precautions.....	7-2
Precautions on seat belt usage.....	2-16
Precautions when driving.....	4-16
Precautions when starting and driving... ..	4-2
Push starting.....	5-7

R

Radio.....	3-13
AM-FM radio with cassette player.....	3-22
AM-FM radio with cassette player (Active speaker system).....	3-18
AM-FM radio with cassette player and compact disc player.....	3-25
AM-FM radio with cassette player (Bose audio system).....	3-14
CB radio or car phone.....	3-31
Radio operation.....	3-26
Rear window defogger switch.....	1-14
Recommended SAE viscosity number.....	9-6
Reporting safety defects.....	9-17

S**Safety**

Child safety rear door lock.....	2-3
Reporting safety defects.....	9-16
Seat adjustment.....	2-13
Seat belt	
Automatic seat belt system (For U.S.A.).....	2-17

Installation on front passenger seat (For U.S.A.- automatic seat belt)	2-29
Precautions on seat belt usage	2-16
Seat belt extenders (Except for the automatic seat belt)	2-25
Seat belt maintenance	2-25
Seat belts	2-16
2-point type without retractor	2-23
3-point type with retractor	2-21
Seats	2-13
Spark plug replacement	7-15
Speedometer	1-4, 1-7
Starting	
Before starting the engine	4-5
Jump starting	5-6, 7-15
Precautions when starting and driving ...	4-2
Push starting	5-7
Starting the engine	4-10
Steering	
Power steering fluid	7-13
Tilting steering wheel	2-31
Sun roof	1-20
Supplemental restraint system (Air bag system)	2-10
Switch	
Front fog light switch	1-16
Hazard warning flasher switch	1-17
Headlight and turn signal switch	1-15
Ignition switch	4-3
Outside mirror defogger switch	1-14
Rear window defogger switch	1-14
Windshield wiper and washer switch ...	1-13

T

Tachometer	1-4, 1-7
Temperature conditions for checking	7-11
Theft warning	1-12
Three-way catalyst	4-2
Tilting steering wheel	2-31
Tire	
Flat tire	5-2
Tire chains	7-30
Tire placard	9-11
Uniform tire quality grading	9-15
Wheels and tires	7-28, 9-8
Tow truck towing	5-8
Towing	
Tow truck towing	5-8
Trailer towing	9-13
Trailer towing	9-13
Transmission	
Automatic transmission fluid	7-11
Driving with automatic transmission	4-5
Driving with manual transmission	4-9
Trip odometer	1-7
Trunk lid lock	2-7

U

Uniform tire quality grading	9-16
------------------------------------	------

V

Vehicle identification	9-9
------------------------------	-----

Vehicle identification number (Chassis number)	9-10
Vehicle identification number plate	9-9
Vehicle identification plate	9-9
Ventilator	3-2

W

Warning	
Air bag information and warning labels	2-12
Air bag warning light	2-11
Hazard warning flasher switch	1-17
Theft warning	1-12
Warning/indicator light and chime	1-9
Wheels and tires	7-28, 9-8
When traveling or registering your vehicle in another country	9-9
Window washer fluid	7-13
Windshield wiper and washer switch	1-13
Wiper	
Windshield wiper and washer switch ...	1-13
Wiper blades	7-18

MEMO

AS STATION INFORMATION

Recommended fuel:

VG30 engine models

Unleaded gasoline with an octane rating of at least 87 AKI (Anti-Knock Index) number (Research octane number 91).

For improved vehicle performance, the use of premium unleaded gasoline with an octane rating of at least 91 AKI number (Research octane number 96) is recommended.

VE30DE engine models

Unleaded premium gasoline with an octane rating of at least 91 AKI (Anti-Knock Index) number (Research octane number 96)

If unleaded premium gasoline is not available, unleaded regular gasoline with an octane rating of at least 87 AKI (Research octane number 91) can be used.

However, for maximum vehicle performance, the use of unleaded premium gasoline is recommended.

CAUTION:

Using a fuel other than that specified could adversely affect the emission control devices and systems, and could also affect the warranty coverage validity.

Under no circumstances should a leaded gasoline be used, since this will damage the three-way catalyst.

For further details such as gasohol, see "Fuel recommendation" in the "Technical and consumer information" section.

Recommended engine oil:

Energy Conserving Oils of API SG, SAE 5W-30 is preferable for all ambient temperatures. See "Engine oil and oil filter recommendation" in the "Technical and consumer information" section.

Tire cold pressure:

See tire placard affixed to the center console lid.

QUICK REFERENCE

	(page)
● In case of emergency (Flat tire, engine will not start, overheating, towing)	5-1
● How to start the engine	4-1
● How to read the meters and gauges	1-1
● Maintenance schedule	8-1
● Do-it-yourself operations	7-1
● Technical and consumer information.....	9-1

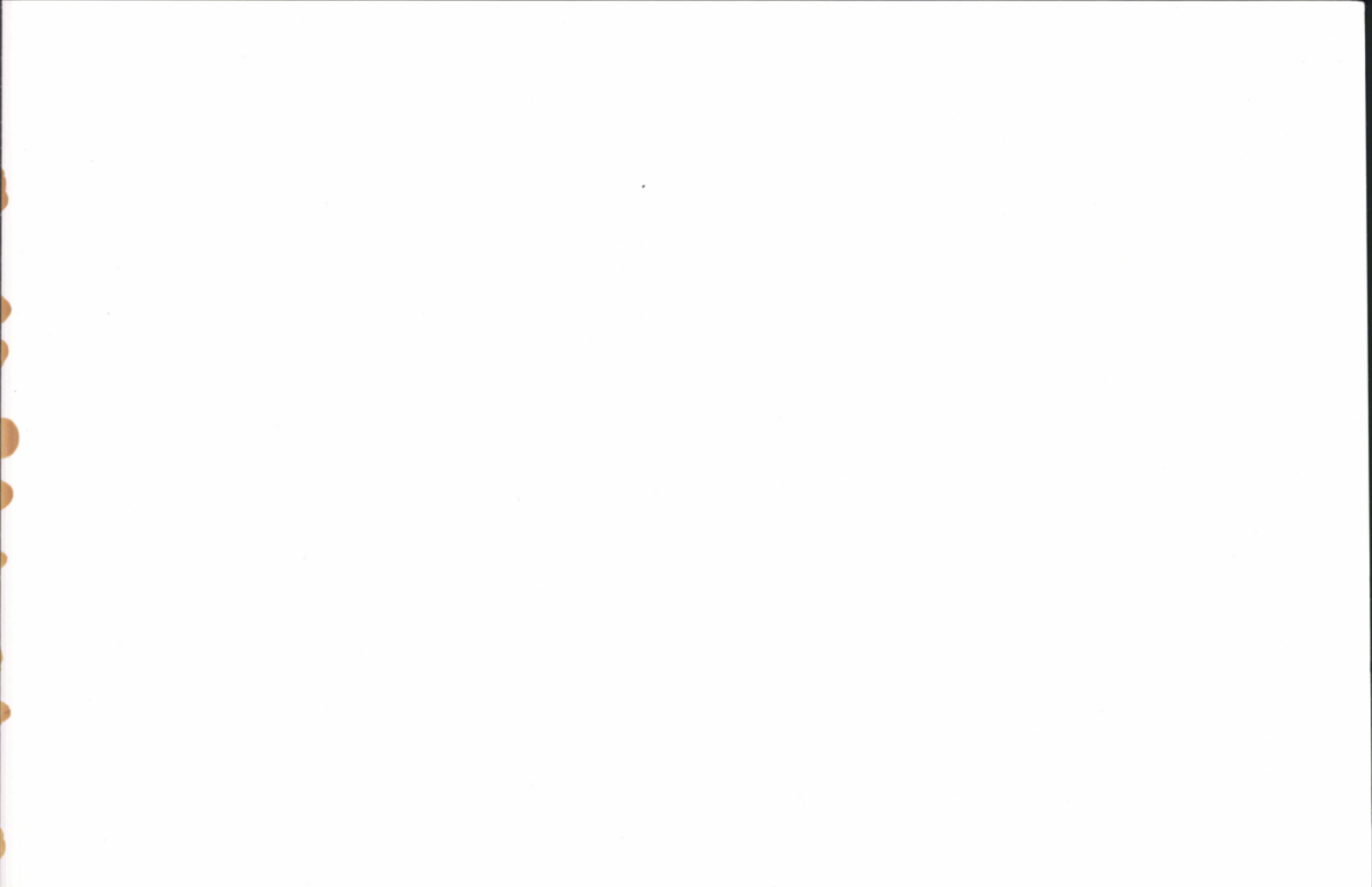



NISSAN

'93

J30-D

Printing: September 1992 (30)
Publication No. OM3E-0J30U0
Printed in Japan